

POWER LINE

high performance air motors from 1.6 to 18 kW

The high starting torque on this machine, its unrivalled light weight, as well as its robust and reliable design are clear advantages in comparison with any electric drive.
 The product line of versatile high performance foot and flange motors is in a class of its own.

ATEX conform
long life-span

low weight
reliable

robust
high starting torque







18 kW POWER LINE motor with IEC flange



OVERVIEW PRODUCT SPECTRUM POWER LINE MOTORS

The DEPRAG product spectrum consists of a variety of gear motors. If you cannot find a suitable motor for your application please contact us. As well as our catalogue range we offer low-cost customised system solutions.

POWER LINE motors ATEX conform with integrated holding brake

A =		 II 2G Ex h IIC T6 Gb X
		 II 2D Ex h IIIC T80 °C Db X
B =		 II 2G Ex h IIC T5 Gb X
		 II 2D Ex h IIIC T95 °C Db X
C =		 II 2G Ex h IIC T4 Gb X
		 II 2D Ex h IIIC T130 °C Db X
D =		 II 2G Ex h IIC T3 Gb X
		 II 2D Ex h IIIC T195 °C Db X

POWER LINE motors – the smallest design size with the highest torque capacity.

If you require different speed rates, then we combine these motors with planetary-, worm-, or spur-gears that are ATEX compliant.

Your advantages:

- compact size
- high degree of efficiency

Performance class:

1.6 kW	Page 4
3.2 kW	Page 14
5.0 kW	Page 24
6.0 kW	Page 32

Accessories:

silencer	Page 42
maintenance unit	Page 43

POWER LINE motors with planetary gears



POWER LINE motors - high torque in a small package.

Without gears or optionally with precision planetary gears.

Your advantages:

- compact size
- high degree of efficiency
- choice of mounting position
- translation 5-50

Performance class:

1.6 kW	Page 6
3.2 kW	Page 16

Accessories:

silencer	Page 42
holding brake	Page 40
maintenance unit	Page 44

POWER LINE motors with worm gears



POWER LINE motors with worm gears are used when self-locking gears are required.

Your advantages:

- low-cost
- compact design
- high translation possible at a level of 14 - 80
- self-locking

Performance class:

1.6 kW	Page 8/10
3.2 kW	Page 18/20
5.0 kW	Page 28/29

Technical Information:

mounting position	Page 38
spindle designs	Page 41
flange designs	Page 41

Accessories:

maintenance unit	Page 44
------------------	---------

POWER LINE motors with spur gears



POWER LINE motors with spur gear offer user-defined translation options.

Your advantages:

- low cost
- translation: optional (i = 7 - 238)

Performance class:

1.6 kW	Page 12
3.2 kW	Page 22
5.0 kW	Page 30/31

Technical Information:

mounting position	Page 39
-------------------	---------

Accessories:

maintenance unit	Page 44
------------------	---------

POWER LINE High performance motors with integrated planetary gears provide highest torque.

- They are available in
- flange design (FM)
 - foot design (KM)

Reversal via external valve
ATEX conform

Performance class:
9 kW Page 34
18 kW Page 34

Reversal via lever
without ATEX specification

Performance class:
1.9 kW Page 36
3.3 kW Page 36
4.6 kW Page 36

POWER LINE
High performance motors



THE DESIGN OF YOUR AIR MOTOR:

Calculating the motor performance:

$$P = \frac{M \times n}{9550}$$

P = Power output in kW
M = Nominal torque in Nm
n = Nominal speed in rpm

Power [HP] = P [kW] x 1.34
Torque [in.lbs] = M [Nm] x 8.85

The optimal working range of an air motor is close to the nominal speed.

If you require lower speeds than those mentioned in the catalogue then you can reduce the speed smoothly by throttling the exhaust air without significant loss of performance or torque.

By throttling the supply air or decreasing the operating pressure the speed, the torque and the performance of the motor can be reduced.

All performance data for DEPRAG air motors is based on operating pressure of 6 bar and the minimum allowable opening cross-section of the feed hose as stated in each motor's data.

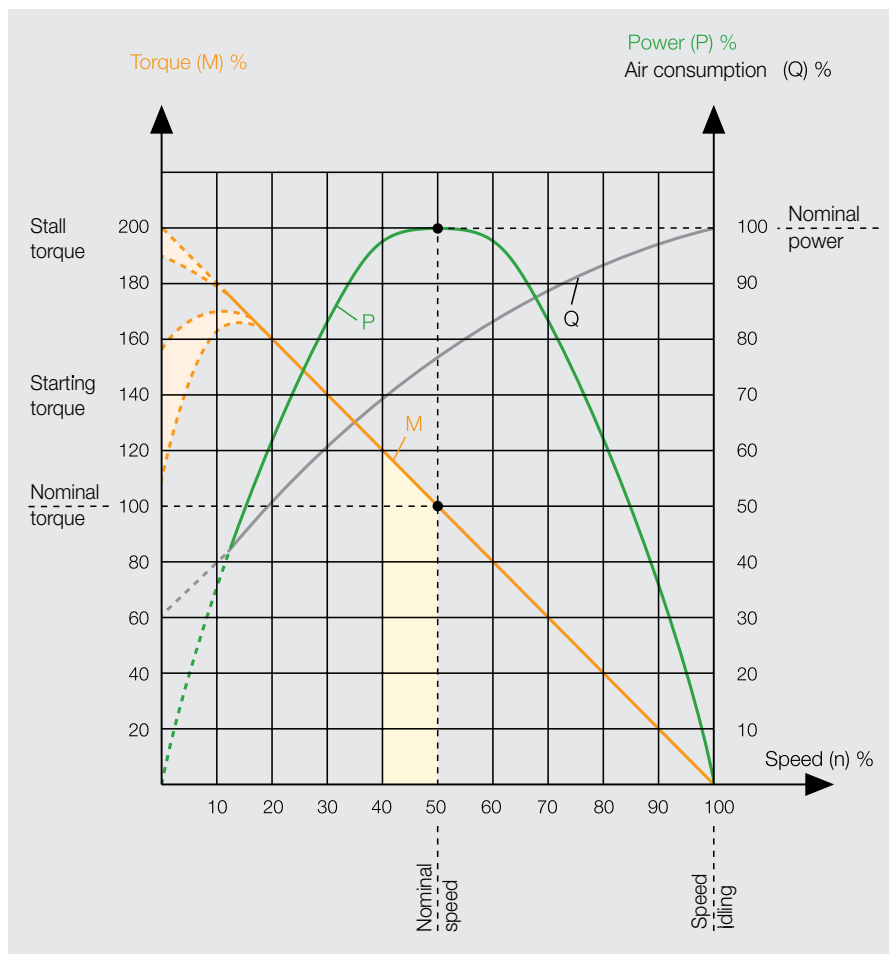

If your surrounding conditions vary from this you will find a comprehensive guide to our motors in brochure D6000E. We will also be happy to answer any questions directly.



= optimal working range of the air motor

1.6 kW POWER LINE motors

The motors in this design series can be operated in either right- or left rotation. Alternatively, the motor can also be reversed by two external 3/2-way valves or one 5/3-way valve.

Motor size 9		Flange motor reversible				
ATEX conform		Type	68X-001F09/IEC71 without gear	68X-003F09/IEC80 spur gear	68X-007F09/IEC80 planetary gear	68X-007F09/IEC71-VA stainless design
		Part no.	440908B	440901B	440900B	110009A
			D	D	D	D
ATEX specification						
Nominal power	kW/HP	1.6 / 2.1	1.6 / 2.1	1.6 / 2.1	1.6 / 2.1	1.6/2.1
Nominal speed	rpm	4500	1500	700	4500	
Speed (idling)	rpm	9000	3000	1400	9000	
Nominal torque	Nm/in.lbs	3.3 / 29	10.2 / 90	21.5 / 190	3.3 / 29	
Start torque min.	Nm/in.lbs	5 / 44	15.3 / 135.4	32.2 / 285	5 / 44	
Stall torque	Nm/in.lbs	6.3 / 55.8	19.4 / 171.7	41.5 / 367.28	6.3 / 55.8	
Permissible radial force max.	N/lbs	360 / 80.64	1100 / 246.4	1500 / 336	240 / 53.76	
Permissible axial force max.	N/lbs	190 / 42.56	760 / 170.24	480 / 107.52	150 / 33.6	
Air consumption	m ³ /min/cfm	1.9 / 67	1.9 / 67	1.9 / 67	1.9 / 67	
Weight	kg/lbs	5.2 / 11.44	9.5 / 20.9	9.5 / 20.9	5.7 / 12.54	
Hose I.D., supply air/exhaust air	mm/in.	15 ⁵ / ₈ / 19 ³ / ₄	15 ⁵ / ₈ / 19 ³ / ₄	15 ⁵ / ₈ / 19 ³ / ₄	15 ⁵ / ₈ / 19 ³ / ₄	
Motor size 9 with holding brake		Flange motor reversible				
ATEX conform		Type	68X-001F09B/IEC71 without gear	68X-003F09B/IEC80 spur gear	68X-007F09B/IEC80 planetary gear	
		Part no.	445341B	440658B	445341M	
			D	D	D	
ATEX specification						
without ATEX authorization						
		68-001F09B/IEC71 without gear	68-003F09B/IEC80 spur gear	68-007F09B/IEC80 planetary gear		
		110909A	110909B	110909C		
Nominal power	kW/HP	1.6 / 2.1	1.6 / 2.1	1.6 / 2.1		
Nominal speed	rpm	4500	1500	700		
Speed (idling)	rpm	9000	3000	1400		
Nominal torque	Nm/in.lbs	3.3 / 29	10.2 / 90	21.5 / 190		
Start torque min.	Nm/in.lbs	5 / 44	15.3 / 135.4	32.2 / 285		
Stall torque	Nm/in.lbs	6.3 / 55.8	19.4 / 171.7	41.5 / 367.28		
Brake torque	Nm/in.lbs	6.6 / 58.41	20.4 / 180.54	43 / 380.55		
Permissible radial force max.	N/lbs	360 / 80.64	1100 / 246.4	1500 / 336		
Permissible axial force max.	N/lbs	190 / 42.56	760 / 170.24	480 / 107.52		
Air consumption	m ³ /min/cfm	1.9 / 67	1.9 / 67	1.9 / 67		
Weight	kg/lbs	5.2 / 11.44	9.5 / 20.9	9.5 / 20.9		
Hose I.D., supply air/exhaust air	mm/in.	15 ⁵ / ₈ / 19 ³ / ₄	15 ⁵ / ₈ / 19 ³ / ₄	15 ⁵ / ₈ / 19 ³ / ₄		

Performance data relate to an air pressure of 6 bar (85 PSI) and lubricated air

Optional equipment

	Part no.	445033B	445033D	445033E	107867A
Spare parts kit	Part no.	445033B	445033D	445033E	107867A
Spare parts kit for brake	Part no.	445033B	445033D	445033E	-

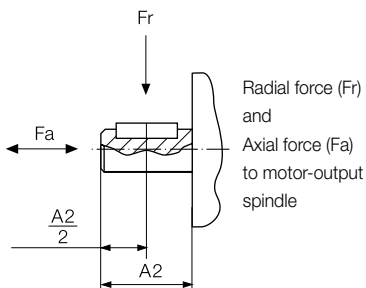

Holding brake (not ATEX conform) on page 40

Silencer on page 42

Maintenance unit on page 44

Model number description on page 46

68(X)-001F09(B)/IEC71

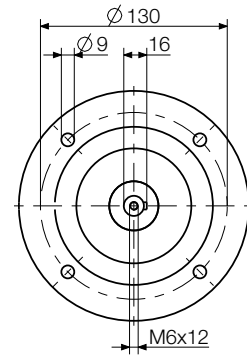
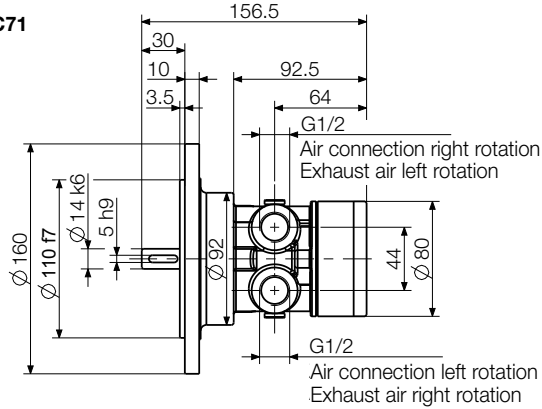

68(X)-003F09(B)/IEC80

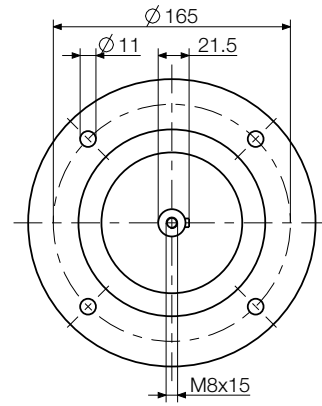
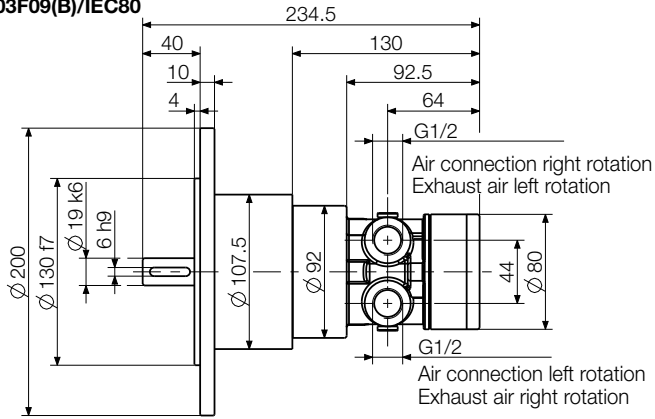

68(X)-007F09(B)/IEC80

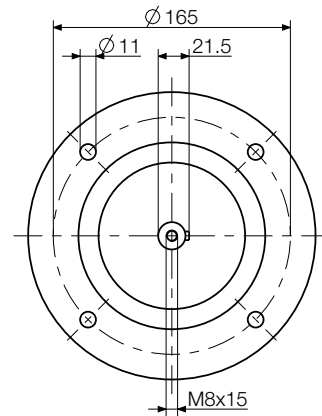
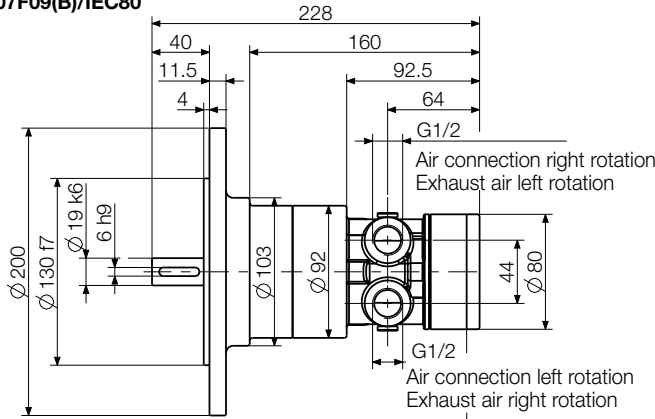

Braking system
445709B

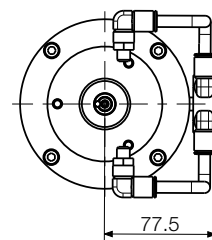
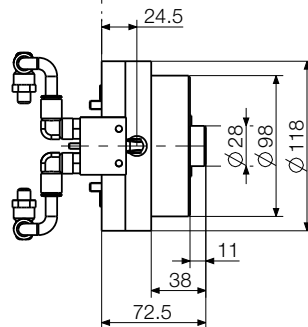

1.6 kW POWER LINE motors with planetary gears

Motor size 9 with planetary gear		Flange motor	
Motor, reversible	Type Part no.	68-P010F-000-09/1 118300B	68-P025F-000-09/1 118300C
Nominal power	kW / HP	1.6 / 2.1	1.6 / 2.1
Nominal speed	rpm	450	180
Max. admissible speed	rpm	700	280
Nominal torque	Nm / in.lbs	32 / 283	82.5 / 730
Start torque min.	Nm / in.lbs	48 / 425	124 / 1097.4
Stall torque	Nm / in.lbs	60 / 531	157 / 1389.45
Permissible radial force max.	N / lbs	2800 / 627.2	5000 / 1120
Permissible axial force max.	N / lbs	1900 / 425.6	4000 / 896
Air consumption	m ³ /min / cfm	1.9 / 67	1.9 / 67
Weight	kg / lbs	8.3 / 18.3	15.4 / 33.9
Hose I.D., supply air/exhaust air	mm / in.	15 ⁵ / ₈ / 19 ³ / ₄	15 ⁵ / ₈ / 19 ³ / ₄
Gear type		P90F	P120F
Max. gear torque for permanent load	Nm / in.lbs	144 / 1274.4	400 / 3540

Performance data relate to an air pressure of 6 bar (85 PSI) and lubricated air

Optional equipment		
Spare parts kit	Part no.	445033B

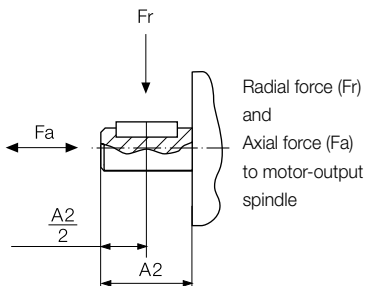

Holding brake
on page 40

Silencer
on page 42

Maintenance unit
on page 44

Model number description
on page 46

68-P010F-000-09/1

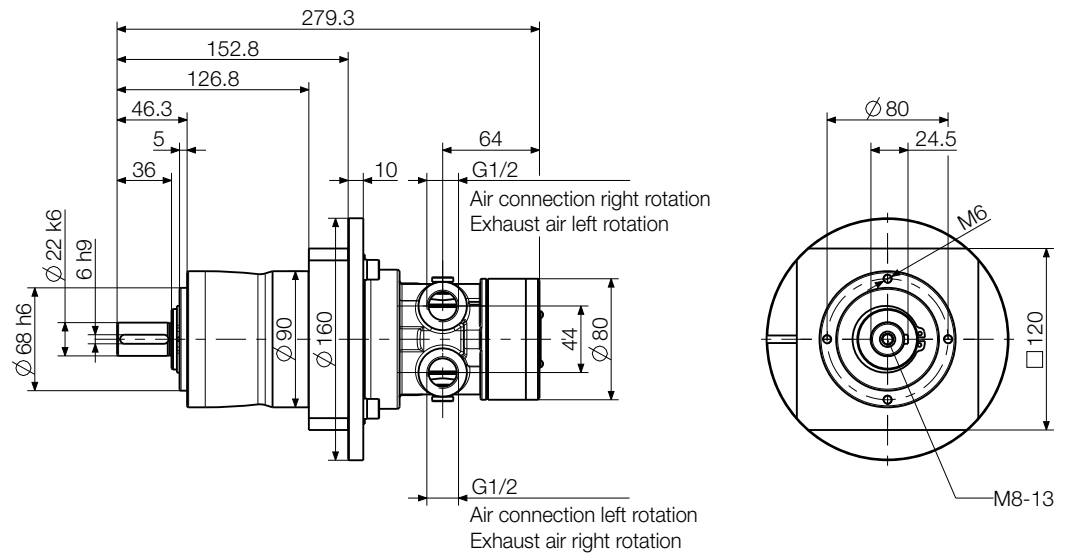

68-P025F-000-09/1

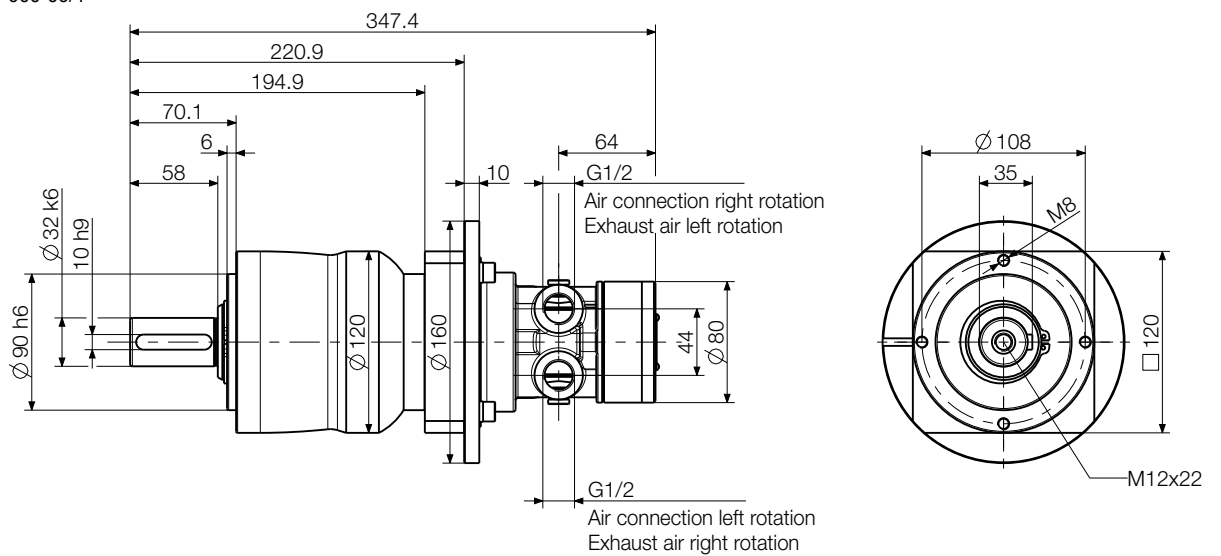

Dimensions in mm

p1069741

1.6 kW POWER LINE motors with worm gears

The motors in this design series can be operated in either right- or left rotation. Alternatively, the motor can also be reversed by two external 3/2-way valves or one 5/3-way valve.

Motor size 9 with worm gear		Flange motor	Bracket motor
Motor, reversible	Type Part no.	68-W014F1- . . . -09 444858A-F ¹⁾ 68-W014F2- . . . -09 444858G-M ¹⁾	68-W014KA- . . . -09 444862A-F ¹⁾
Nominal power	kW / HP	1.6 / 2.1	1.6 / 2.1
Nominal speed	rpm	320	320
Speed (idling)	rpm	430 ²⁾	430 ²⁾
Nominal torque	Nm / in.lbs	40 / 354	40 / 354
Start torque min.	Nm / in.lbs	42 / 371.7	42 / 371.7
Air consumption	m ³ /min / cfm	1.9 / 67	1.9 / 67
Weight	kg / lbs	8.2 / 18	8.2 / 18
Hose I.D., supply air/exhaust air	mm / in.	15 ⁵ / ₈ / 19 ³ / ₄	15 ⁵ / ₈ / 19 ³ / ₄
Gear type		W49F	W49KA
Max. gear torque for permanent load	Nm / in.lbs	49 / 433.7	49 / 433.7

Performance data relate to an air pressure of 6 bar (85 PSI) and lubricated air

¹⁾ F1: A / B / C / D / E / F = mounting position 0B3 / 0B6 / 0B7 / 0B8 / 0V5 / 0V6
 F2: G / H / I / K / L / M = mounting position 0B3 / 0B6 / 0B7 / 0B8 / 0V5 / 0V6
 (Example: mounting position 0B6 = Part no. XXXXXX B)
²⁾ max. admissible speed (idling)

Optional equipment		
Spare parts kit	Part no.	445033B

▶ Mounting positions on page 38	▶ Permissible radial and axial forces on page 41	▶ Spindle designs on page 41	▶ Silencer on page 42
▶ Maintenance unit on page 44	▶ Model number description on page 46		

Design with flange F2
i.e. 68-W014F2-OB3-09

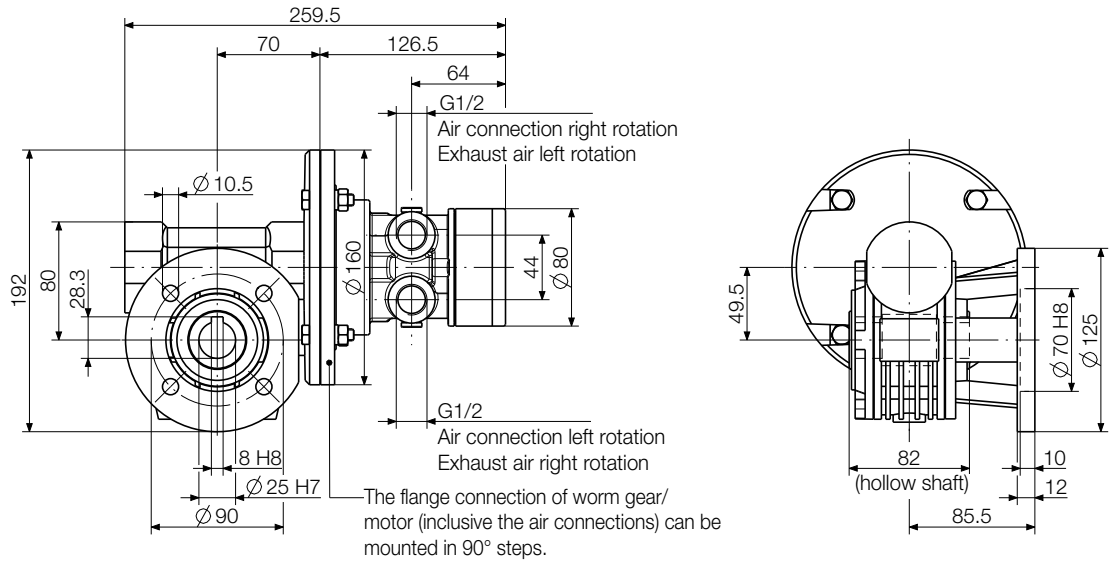

Design with flange F1
i.e. 68-W014F1-OB3-09

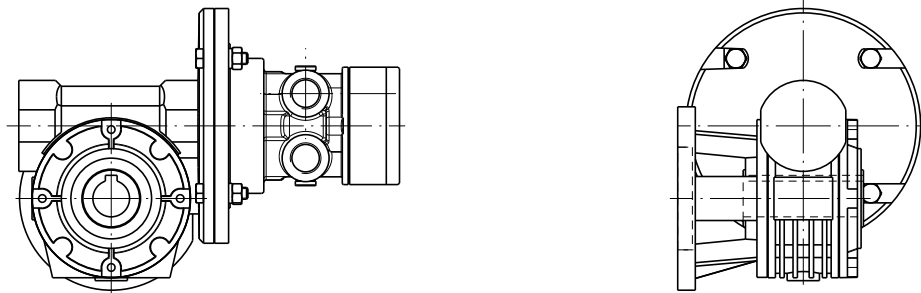

Design with bracket
i.e. 68-W014KA-OB3-09

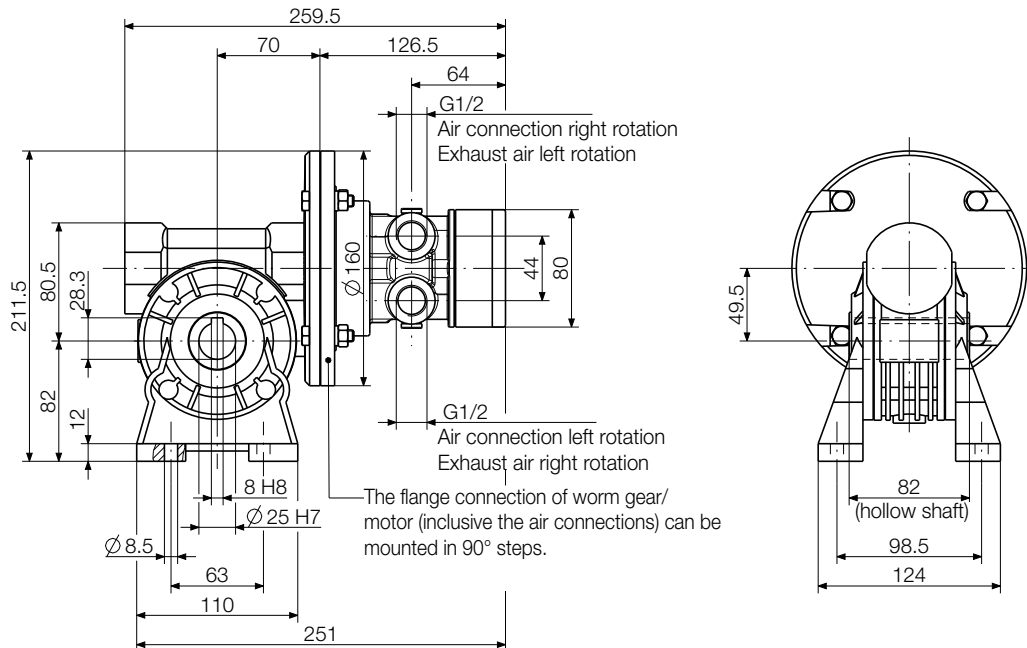

1.6 kW POWER LINE motors with worm gears

The motors in this design series can be operated in either right- or left rotation.
Alternatively, the motor can also be reversed by two external 3/2-way valves or one 5/3-way valve.

Motor size 9 with worm gear		Universal mounting		
Motor, reversible	Type Part no.	68-W030U-. . .-09 446225A-F 1)	68-W064U-. . .-09 446226A-F 1)	68-W080U-. . .-09 446227A-F 1)
Nominal power	kW / HP	1.6 / 2.1	1.6 / 2.1	1.6 / 2.1
Nominal speed	rpm	150	70	55
Speed (idling)	rpm	200 2)	95 2)	75 2)
Nominal torque	Nm / in.lbs	79 / 699	159 / 1407	191 / 1690
Start torque min.	Nm / in.lbs	67 / 593	121 / 1071	137 / 1212
Air consumption	m ³ /min / cfm	1.9 / 67	1.9 / 67	1.9 / 67
Weight	kg / lbs	11.5 / 25.3	18.8 / 41.4	18.8 / 41.4
Hose I.D., supply air/exhaust air	mm / in.	15 ⁵ / ₈ / 19 ³ / ₄	15 ⁵ / ₈ / 19 ³ / ₄	15 ⁵ / ₈ / 19 ³ / ₄
Gear type		W63U	W86U	W86U
Max. gear torque for permanent load	Nm / in.lbs	125 / 1106	250 / 2212	225 / 1991

Performance data relate to an air pressure of 6 bar (85 PSI) and lubricated air

1) A / B / C / D / E / F = mounting position 0B3 / 0B6 / 0B7 / 0B8 / 0V5 / 0V6
(Example: mounting position 0B6 = Part no. XXXXXX B)

2) max. admissible speed (idling)

Using the universal mounting the motor can be fixed flexibly.
As well as direct mounting, indirect mounting via a flange (F/FC) is also possible.

Optional equipment		
Spare parts kit	Part no.	445033B
Flange	Part no.	see on page 39

Type	Dimensions (mm)																		
	A1	A2	A3	A4	A5	A6	B1-a	B1-b	B2-a	B2-b	B3-a	B3-b	B3-c	B4-a	B4-b	B5-a	B5-b	B6-a	B6-b
68-W030U	294	182.5	145	72.5	72.5	94	75	115	3	5	56	116	86	90	150	M8x14	11	105	180
68-W064U	355	245.5	200	100	100	125	110	152	3.5	6	68	151	110.5	130	176	M10x18	12.5	150	210
68-W080U																			
	B7	C1	C2	C3	C4	D1	D2	D3	D4	D5	D6	D7	D8						
68-W030U	11	28.3	8	25	120	102	102	37.5	76	102	51	8	9						
68-W064U	15	38.3	10	35	140	144	144	45.5	101	144	72	11	11.5						
68-W080U																			

▶ Shaft load on page 41	▶ Permissible radial and axial forces on page 41	▶ Flange designs F/FC on page 41	▶ Silencer on page 42
▶ Maintenance unit on page 44	▶ Model number description on page 46		

Standard design without flange
i.e. 68-W030U-OB3-09

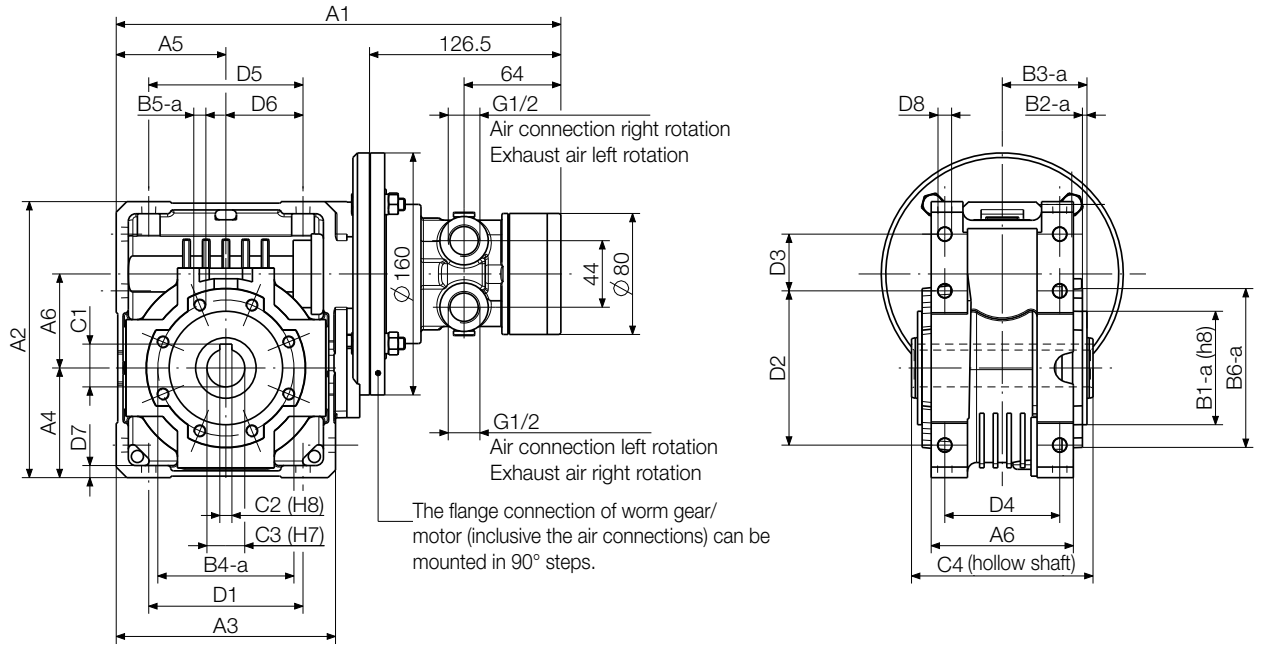

Flange F
Adaption possible on both sides
(optional equipment)

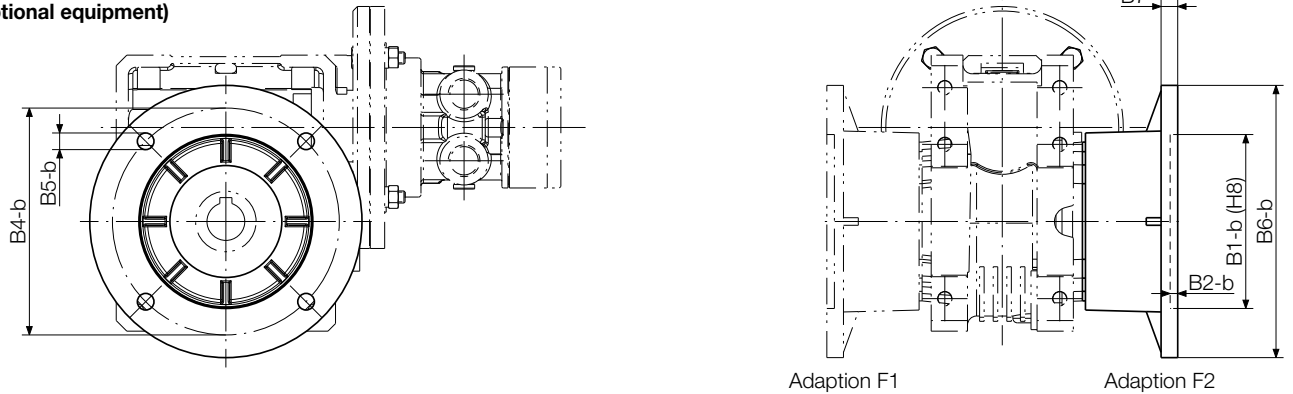

Flange FC
Adaption possible on both sides
(optional equipment)

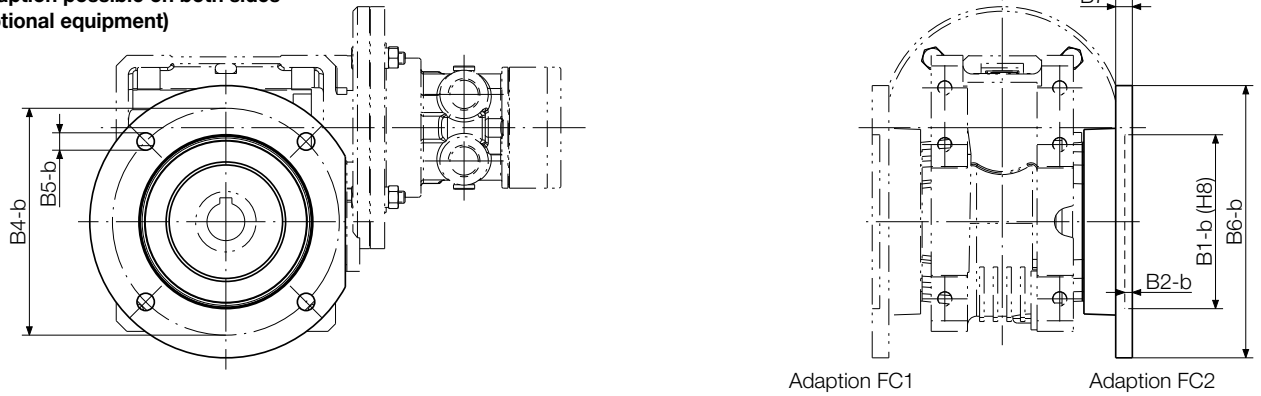

1.6 kW POWER LINE motors with spur gears

The motors in this design series can be operated in either right- or left rotation. Alternatively, the motor can also be reversed by two external 3/2-way valves or one 5/3-way valve.

Motor size 9 with spur gear		Flange motor					
Type		68-S007	68-S016	68-S036	68-S064	68-S135	68-S238
Motor, reversible	Part no.	F-...-09 444845A-C ¹⁾	F-...-09 444846A-C ¹⁾	F-...-09 444847A-C ¹⁾	F-...-09 446233A-C ¹⁾	F-...-09 444849A-C ¹⁾	F-...-09 446241A-C ¹⁾
Nominal power	kW / HP	1.6 / 2.1	1.6 / 2.1	1.6 / 2.1	1.6 / 2.1	1.6 / 2.1	1.6 / 2.1
Nominal speed	rpm	590	280	120	70	33	18
Speed (idling)	rpm	660 ²⁾	320 ²⁾	140 ²⁾	80 ²⁾	37 ²⁾	21 ²⁾
Nominal torque	Nm / in.lbs	24 / 212.4	50 / 442.5	120 / 1062	197 / 1743	430 / 3805	716 / 6337
Start torque min.	Nm / in.lbs	36 / 318.6	75 / 664	180 / 1593	299 / 2646	645 / 5708	1084 / 9593
Permissible radial force max.	N / lbs	1140 / 255.4	2030 / 454.7	4030 / 902.7	5800 / 1299	10000 / 2240	16000 / 3584
Permissible axial force max.	N / lbs	228 / 51	406 / 91	806 / 180.5	1160 / 260	2000 / 448	3200 / 716.8
Air consumption	m ³ /min / cfm	1.9 / 67	1.9 / 67	1.9 / 67	1.9 / 67	1.9 / 67	1.9 / 67
Weight	kg / lbs	11.2 / 24.6	12.2 / 26.8	14.4 / 31.7	33.2 / 73	53.4 / 117.5	74.7 / 164.3
Hose I.D., supply air/exhaust air	mm / in.	15 ⁵ / ₈ / 19 ³ / ₄	15 ⁵ / ₈ / 19 ³ / ₄	15 ⁵ / ₈ / 19 ³ / ₄	15 ⁵ / ₈ / 19 ³ / ₄	15 ⁵ / ₈ / 19 ³ / ₄	15 ⁵ / ₈ / 19 ³ / ₄
Gear type		S122F	S222F	S322F	S413F	S513F	S614F
Max. gear torque for permanent load	Nm / in.lbs	45 / 398	140 / 1239	280 / 2478	560 / 4956	1000 / 8850	1600 / 14160

Performance data relate to an air pressure of 6 bar (85 PSI) and lubricated air

¹⁾ A / B / C = mounting position 0B5 / 0V1 / 0V3
(Example: mounting position 0V1 = Part no. XXXXXX B)
²⁾ max. admissible speed (idling)

Motor size 9 with spur gear		Bracket motor					
Type		68-S007	68-S016	68-S036	68-S064	68-S135	68-S238
Motor, reversible	Part no.	K-...-09 444851A-F ¹⁾	K-...-09 444852A-F ¹⁾	K-...-09 444853A-F ¹⁾	K-...-09 446234A-F ¹⁾	K-...-09 444855A-F ¹⁾	K-...-09 446242A-F ¹⁾
Nominal power	kW / HP	1.6 / 2.1	1.6 / 2.1	1.6 / 2.1	1.6 / 2.1	1.6 / 2.1	1.6 / 2.1
Nominal speed	rpm	590	280	120	70	33	18
Speed (idling)	rpm	660 ²⁾	320 ²⁾	140 ²⁾	80 ²⁾	37 ²⁾	21 ²⁾
Nominal torque	Nm / in.lbs	24 / 212.4	50 / 442.5	120 / 1062	197 / 1743	430 / 3805	716 / 6337
Start torque min.	Nm / in.lbs	36 / 318.6	75 / 664	180 / 1593	299 / 2646	645 / 5708	1084 / 9593
Permissible radial force max.	N / lbs	1140 / 255.4	2030 / 454.7	4030 / 902.7	5800 / 1299	10000 / 2240	16000 / 3584
Permissible axial force max.	N / lbs	228 / 51	406 / 91	806 / 180.5	1160 / 260	2000 / 448	3200 / 716.8
Air consumption	m ³ /min / cfm	1.9 / 67	1.9 / 67	1.9 / 67	1.9 / 67	1.9 / 67	1.9 / 67
Weight	kg / lbs	11.2 / 24.6	12.2 / 26.8	14.4 / 31.7	33.2 / 73	53.4 / 117.5	74.7 / 164.3
Hose I.D., supply air/exhaust air	mm / in.	15 ⁵ / ₈ / 19 ³ / ₄	15 ⁵ / ₈ / 19 ³ / ₄	15 ⁵ / ₈ / 19 ³ / ₄	15 ⁵ / ₈ / 19 ³ / ₄	15 ⁵ / ₈ / 19 ³ / ₄	15 ⁵ / ₈ / 19 ³ / ₄
Gear type		S122K	S222K	S322K	S413K	S513K	S614K
Max. gear torque for permanent load	Nm / in.lbs	45 / 398	140 / 1239	280 / 2478	560 / 4956	1000 / 8850	1600 / 14160

Performance data relate to an air pressure of 6 bar (85 PSI) and lubricated air

¹⁾ A / B / C / D / E / F = mounting position 0B3 / 0B6 / 0B7 / 0B8 / 0V5 / 0V6
(Example: mounting position 0B7 = Part no. XXXXXX C)
²⁾ max. admissible speed (idling)

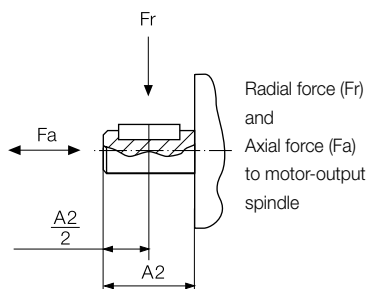

Optional equipment

Spare parts kit	Part no.	445033B
-----------------	----------	---------

Mounting positions
on page 39

Silencer
on page 42

Maintenance unit
on page 44

Model number description
on page 46

Flange motor
i.e. 68-S007F-OB3-09

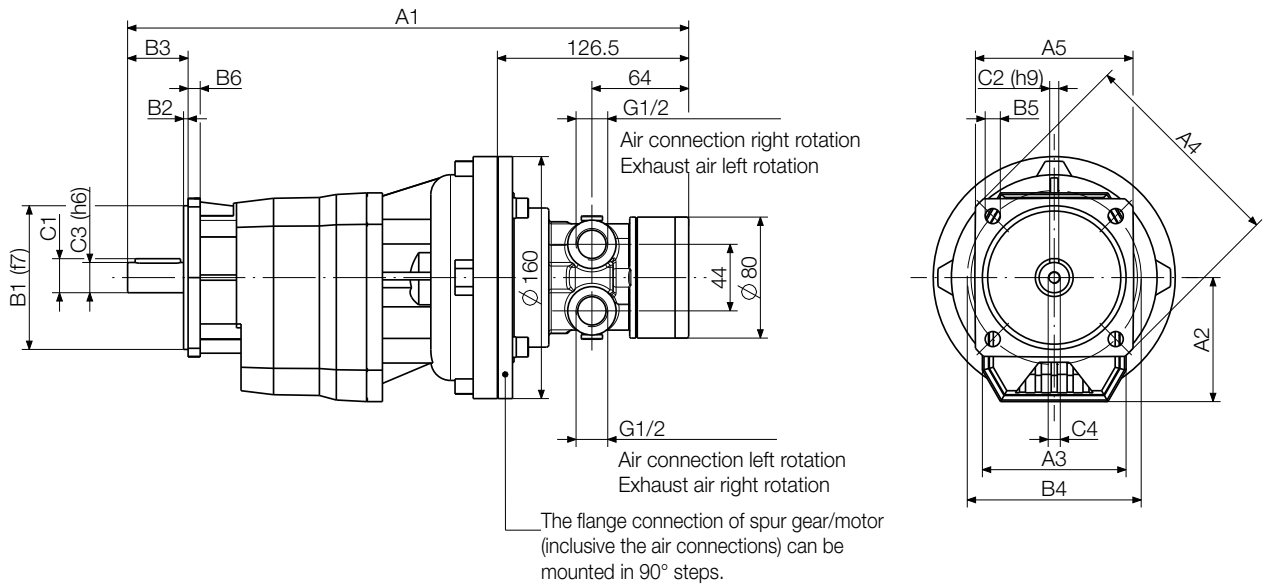

Dimensions in mm

p107103

Motor size 9

Type	Dimensions flange motor (mm)														
	A1	A2	A3	A4	A5	B1	B2	B3	B4	B5	B6	C1	C2	C3	C4
68-S007	371	82	95	140	□105	95	3	40	115		8	22.5	6	20	
68-S016	400	94	110	160	□110	110	3.5	50	130	9.5	10	28	8	25	M8x19
68-S036	434	108	130	200	□150	130	3.5	60	165	11.5	12	33		30	M10x22
68-S064	463	128	155	250		180	4	70	215	14	13	38	10	35	
68-S135	489	152	185	300	-	230	4	80	265	14	16	43	12	40	M12x28
68-S238	616	178.5	210	350		250	5	100	300	18	18	53.5	14	50	M16x36

Bracket motor
i.e. 68-S007K-OB3-09

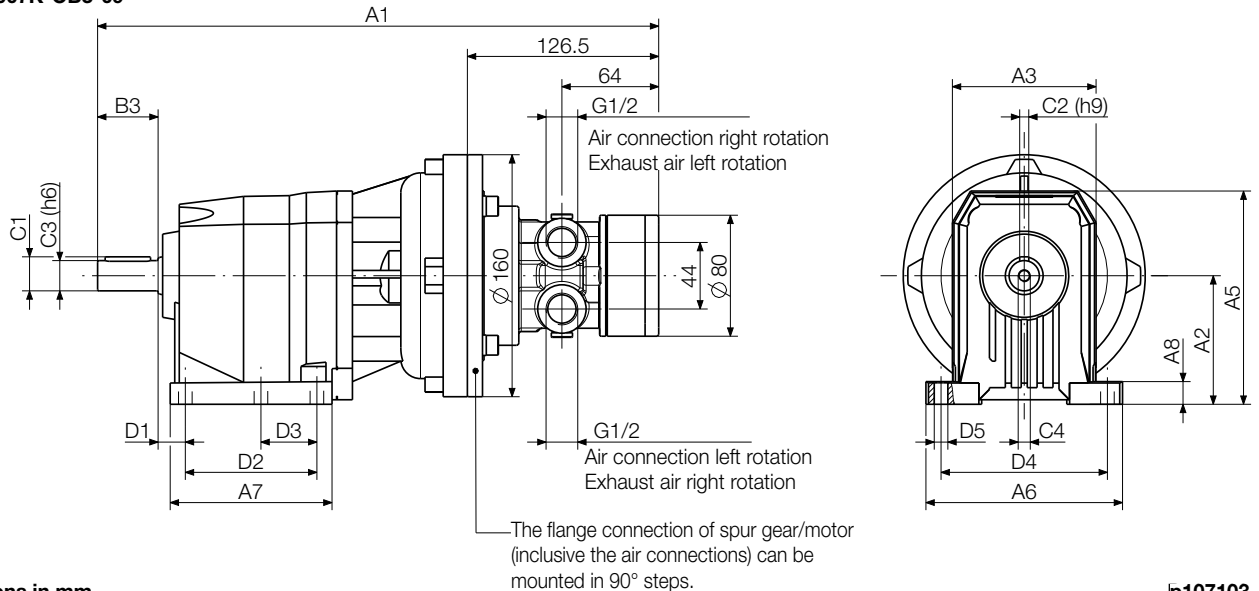



Dimensions in mm

p107103

Type	Dimensions bracket motor (mm)																		
	A1	A2	A3	A5	A6	A7	A8	B3	C1	C2	C3	C4	D1	D2	D3	D4	D5		
68-S007	371	85	95	141	130	107	15	40	22.5	6	20		18	87	37	110	9		
68-S016	400	100	110	166	155	137	17	50	28	8	25	M8x19	18	107.5	47.5	130			
68-S036	434	110	130	181	190	156	20	60	33		30	M10x22	18	130	60	160	11		
68-S064	463	130	155	223	216	185.5	18	70	38	10	35		19.5	149.5		180	14		
68-S135	489	155	185	278	270	200	22	80	43	12	40	M12x28	25	156	-	225			
68-S238	616	195	210	316	300	232	25	100	53.5	14	50	M16x36	25	180		250	18		

3.2 kW POWER LINE motors

The motors in this design series can be operated in either right- or left rotation. Alternatively, the motor can also be reversed by two external 3/2-way valves or one 5/3-way valve.

Motor size 11		Flange motor reversible				
ATEX conform		Type	68X-001F11/IEC80 without gear	68X-002F11/IEC90 spur gear	68X-005F11/IEC90 planetary gear	68X-001F11/IEC80-VA stainless design
		Part no.	440907B	440903B	440902B	110011A
			D	D	D	D
ATEX specification						
Nominal power	kW/HP	3.2 / 4.3	3.2 / 4.3	3.2 / 4.3	3.2 / 4.3	3.2 / 4.3
Nominal speed	rpm	3500	1500	700	3500	
Speed (idling)	rpm	7000	3000	1400	7000	
Nominal torque	Nm/in.lbs	8.7 / 77	20.4 / 180.5	43.6 / 385.9	8.7 / 77	
Start torque min.	Nm/in.lbs	13.1 / 116	30.6 / 270.8	65.5 / 579.7	13.1 / 116	
Stall torque	Nm/in.lbs	16.6 / 146.9	38.7 / 342.5	82.9 / 733.7	16.6 / 146.9	
Permissible radial force max.	N/lbs	260 / 58.24	1600 / 358.4	1900 / 425.6	130 / 29.12	
Permissible axial force max.	N/lbs	220 / 49.28	760 / 170.24	740 / 165.76	180 / 40.32	
Air consumption	m ³ /min/cfm	3.9 / 137.7	3.9 / 137.7	3.9 / 137.7	3.9 / 137.7	
Weight	kg/lbs	10.3 / 22.7	15.4 / 33.9	13.6 / 29.9	11 / 24.2	
Hose I.D., supply air/exhaust air	mm/in.	19 ³ / ₄ / 25 ⁶³ / ₆₄	19 ³ / ₄ / 25 ⁶³ / ₆₄	19 ³ / ₄ / 25 ⁶³ / ₆₄	19 ³ / ₄ / 25 ⁶³ / ₆₄	
Motor size 11 with holding brake		Flange motor reversible				
ATEX conform		Type	68X-001F11B/IEC80 without gear	68X-002F11B/IEC90 spur gear	68X-005F11B/IEC90 planetary gear	
		Part no.	444973E	440657B	444973F	
			D	D	D	
ATEX specification						
without ATEX authorization						
		68-001F11B/IEC80 without gear	68-002F11B/IEC90 spur gear	68-005F11B/IEC90 planetary gear		
		110911A	110911B	110911C		
Nominal power	kW/HP	3.2 / 4.3	3.2 / 4.3	3.2 / 4.3		
Nominal speed	rpm	3500	1500	700		
Speed (idling)	rpm	7000	3000	1400		
Nominal torque	Nm/in.lbs	8.7 / 77	20.4 / 180.5	43.6 / 385.9		
Start torque min.	Nm/in.lbs	13.1 / 116	30.6 / 270.8	65.5 / 579.7		
Stall torque	Nm/in.lbs	16.6 / 146.9	38.7 / 342.5	82.9 / 733.7		
Brake torque	Nm/in.lbs	17.4 / 154	40.8 / 361	87.2 / 771.72		
Permissible radial force max.	N/lbs	260 / 58.24	1600 / 358.4	1900 / 425.6		
Permissible axial force max.	N/lbs	220 / 49.28	760 / 170.24	740 / 165.76		
Air consumption	m ³ /min/cfm	3.9 / 137.7	3.9 / 137.7	3.9 / 137.7		
Weight	kg/lbs	10.3 / 22.7	15.4 / 33.9	13.6 / 29.9		
Hose I.D., supply air/exhaust air	mm/in.	19 ³ / ₄ / 25 ⁶³ / ₆₄	19 ³ / ₄ / 25 ⁶³ / ₆₄	19 ³ / ₄ / 25 ⁶³ / ₆₄		

Performance data relate to an air pressure of 6 bar (85 PSI) and lubricated air

Optional equipment

Optional equipment	Part no.	445034B	445034D	445034E	107871A
Spare parts kit	Part no.	445034B	445034D	445034E	107871A
Spare parts kit for brake	Part no.	445033B	445033D	445033E	-

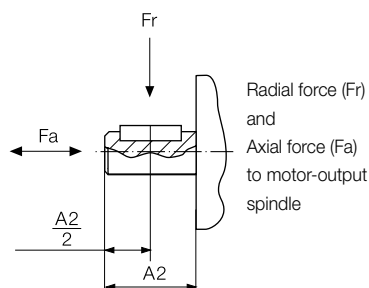

 Holding brake (not ATEX conform) on page 40	 Silencer on page 42	 Maintenance unit on page 44	 Model number description on page 46
---	--	--	--

68(X)-001F11(B)/IEC80

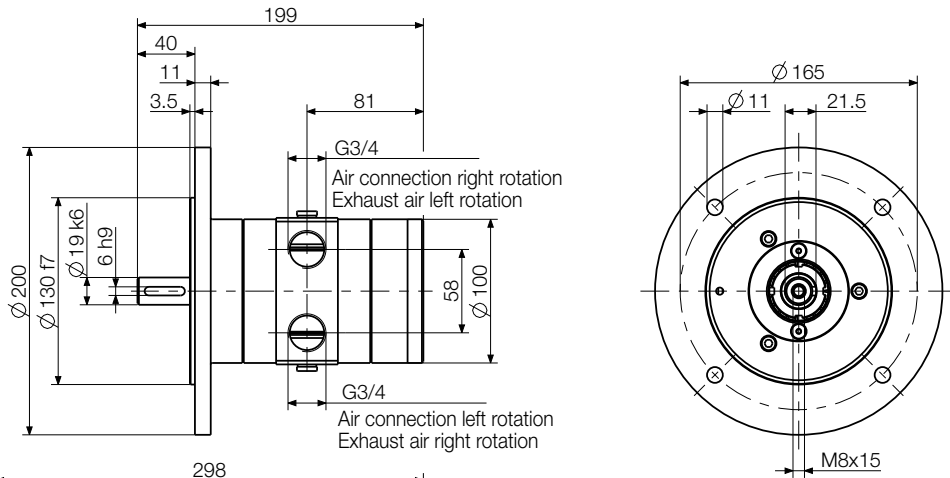

68(X)-002F11(B)/IEC90

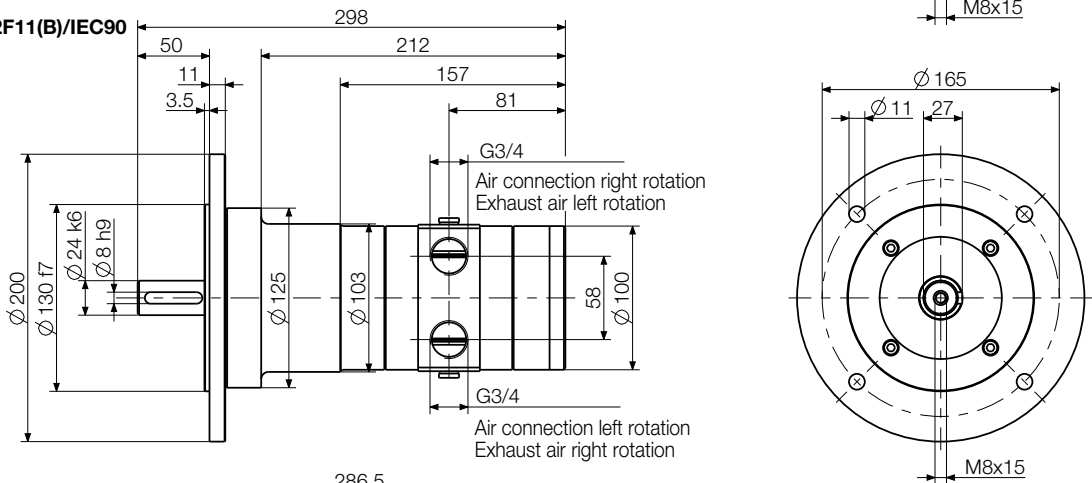

68(X)-005F11(B)/IEC90

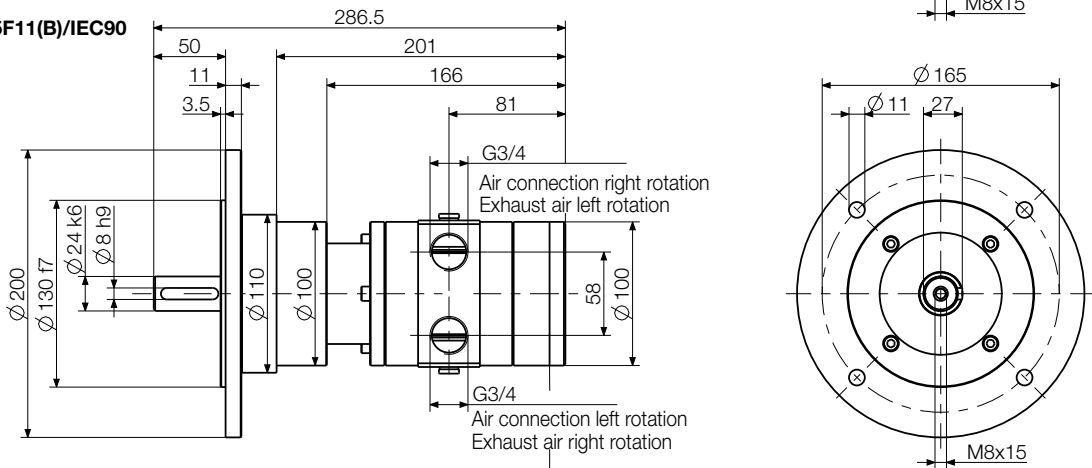

Braking system
446196B

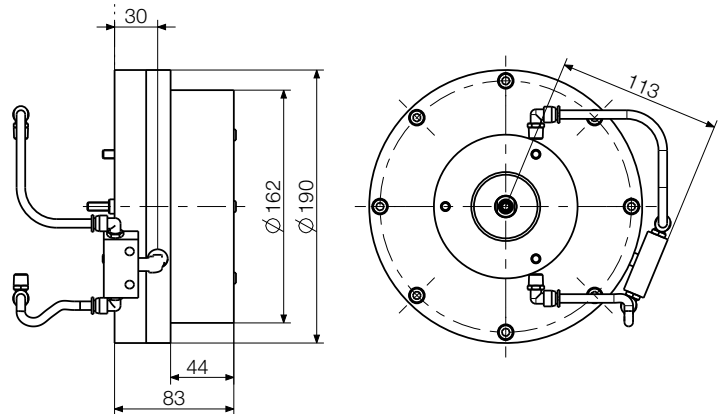

Dimensions in mm

3.2 kW POWER LINE motors with planetary gears

The motors in this design series can be operated in either right- or left rotation. Alternatively, the motor can also be reversed by two external 3/2-way valves or one 5/3-way valve.

Motor size 11 with planetary gear		Flange motor
Motor, reversible	Type Part no.	68-P010F-000-11/1 118310B
Nominal power	kW / HP	3.2 / 4.3
Nominal speed	rpm	350
Speed (idling)	rpm	700
Nominal torque	Nm / in.lbs	87 / 770 ¹⁾
Start torque min.	Nm / in.lbs	131 / 1159.35 ¹⁾
Max. admissible torque	Nm / in.lbs	144 / 1274.4
Permissible radial force max.	N / lbs	2800 / 627.2
Permissible axial force max.	N / lbs	1900 / 425.6
Air consumption	m ³ /min / cfm	3.9 / 137.7
Weight	kg / lbs	16.3 / 35.9
Hose I.D., supply air/exhaust air	mm / in.	19/8 / 25/63/64
Gear type		P90F
Max. gear torque for permanent load	Nm / in.lbs	144 / 1274.4

Performance data relate to an air pressure of 6 bar (85 PSI) and lubricated air

¹⁾ Maximum torque 480 Nm for a maximum of 1000 cycles under load.

Optional equipment	
Spare parts kit	Part no. 445034B

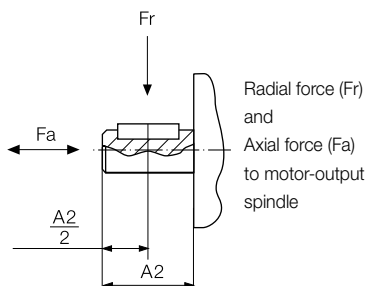

▶ Holding brake
on page 40

▶ Silencer
on page 42

▶ Maintenance unit
on page 44

▶ Model number description
on page 46

68-P010F-000-11

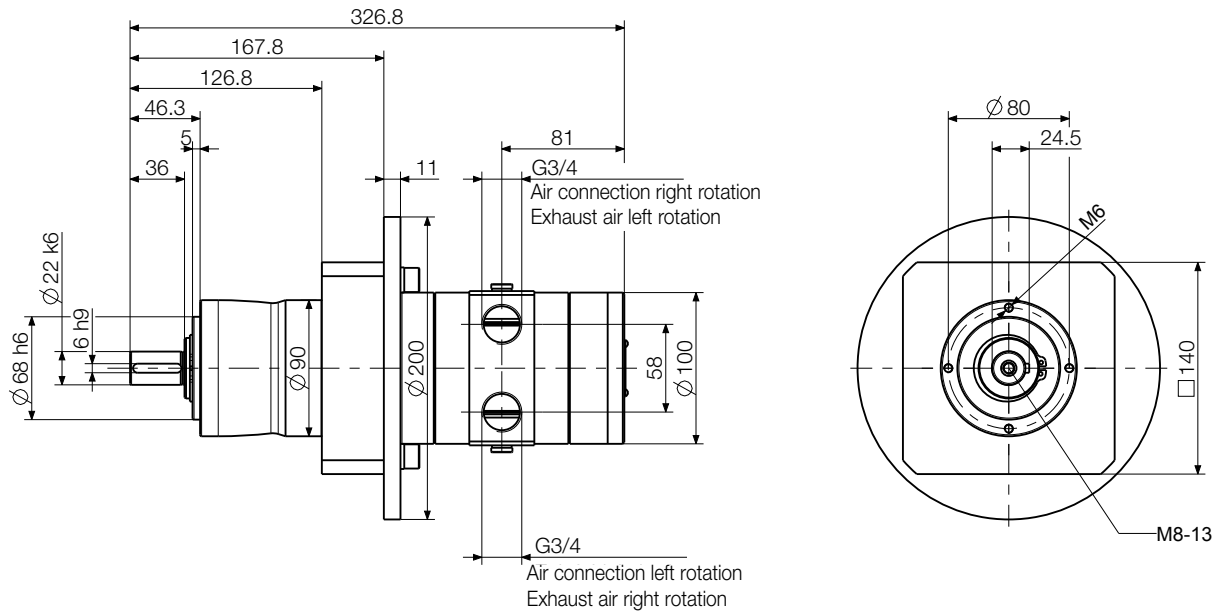

Dimensions in mm

p1059101

3.2 kW POWER LINE motors with worm gears

The motors in this design series can be operated in either right- or left rotation. Alternatively, the motor can also be reversed by two external 3/2-way valves or one 5/3-way valve.

Motor size 11 with worm gear		Universal mounting		
Type	Part no.	68-W010U-...-11 446243A-F ¹⁾	68-W023U-...-11 446228A-F ¹⁾	68-W040U-...-11 446229A-F ¹⁾
Motor, reversible				
Nominal power	kW / HP	3.2 / 4.3	3.2 / 4.3	3.2 / 4.3
Nominal speed	rpm	350	150	85
Speed (idling)	rpm	500 ²⁾	220 ²⁾	125 ²⁾
Nominal torque	Nm / in.lbs	76 / 672.6	170 / 1504.5	280 / 2478
Start torque min.	Nm / in.lbs	86 / 761.1	174 / 1540	240 / 2124
Air consumption	m ³ /min / cfm	3.9 / 137.7	3.9 / 137.7	3.9 / 137.7
Weight	kg / lbs	16.8 / 37	24.1 / 53	24.1 / 53
Hose I.D., supply air/exhaust air	mm / in.	19 ³ / ₄ / 25 ⁶³ / ₆₄	19 ³ / ₄ / 25 ⁶³ / ₆₄	19 ³ / ₄ / 25 ⁶³ / ₆₄
Gear type		W63U	W86U	W86U
Max. gear torque for permanent load	Nm / in.lbs	125 / 1106	285 / 2522	295 / 2611

Performance data relate to an air pressure of 6 bar (85 PSI) and lubricated air

¹⁾ A / B / C / D / E / F = mounting position 0B3 / 0B6 / 0B7 / 0B8 / 0V5 / 0V6
(Example: mounting position 0B6 = Part no. XXXXXX B)

²⁾ max. admissible speed (idling)

Using the universal mounting the motor can be fixed flexibly. As well as direct mounting, indirect mounting via a flange (F/FC) is also possible.

Optional equipment		
Spare parts kit	Part no.	445034B
Flange	Part no.	see on page 39

Motor size 11																			
Type	Dimensions (mm)																		
	A1	A2	A3	A4	A5	A6	B1-a	B1-b	B2-a	B2-b	B3-a	B3-b	B3-c	B4-a	B4-b	B5-a	B5-b	B6-a	B6-b
68-W010U	334	182.5	145	72.5	72.5	94	75	115	3	5	56	116	86	90	150	M8x14	11	105	180
68-W023U	387	245.5	200	100	100	125	110	152	3.5	6	68	151	110.5	130	176	M10x18	12.5	150	210
68-W040U																			
	B7	C1	C2	C3	C4	D1	D2	D3	D4	D5	D6	D7	D8						
68-W010U	11	28.3	8	25	120	102	102	37.5	76	102	51	8	9						
68-W023U	15	38.3	10	35	140	144	144	45.5	101	144	72	11	11.5						
68-W040U																			

▶ Shaft load on page 41	▶ Permissible radial and axial forces on page 41	▶ Flange designs F/FC on page 41	▶ Silencer on page 42
▶ Maintenance unit on page 44	▶ Model number description on page 46		

Standard design without flange
i.e. 68-W010U-OB3-11

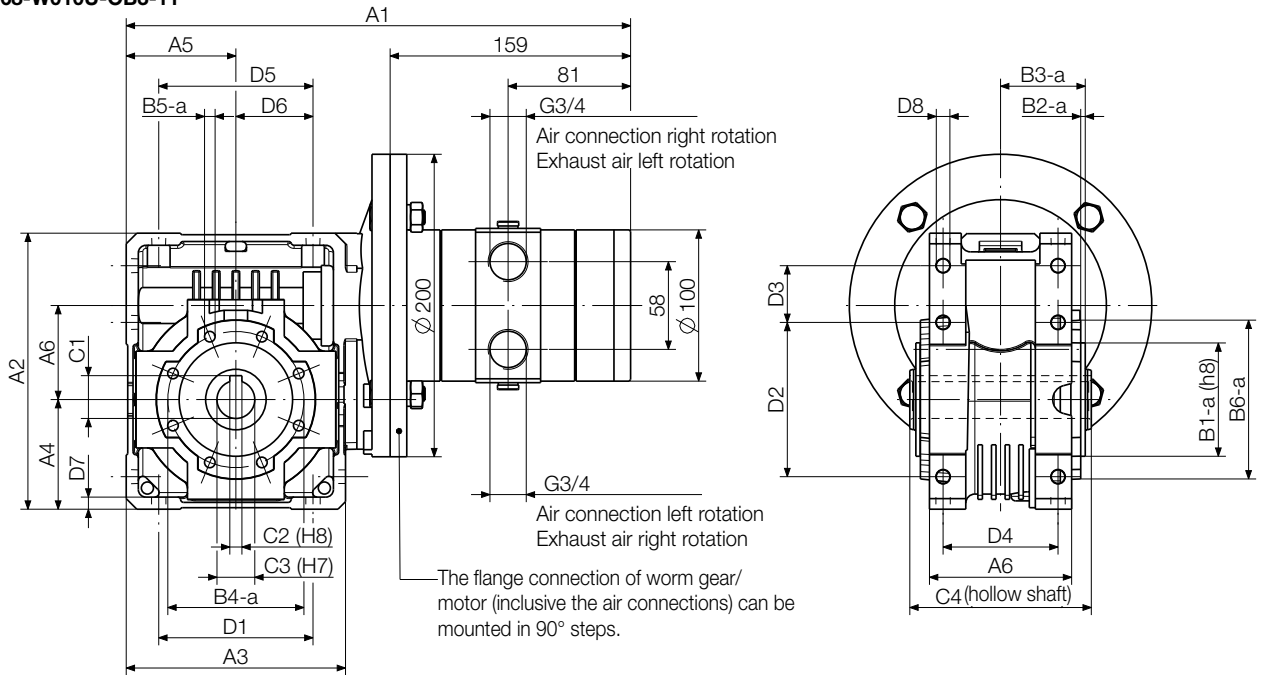

Flange F
Adaption possible on both sides
(optional equipment)

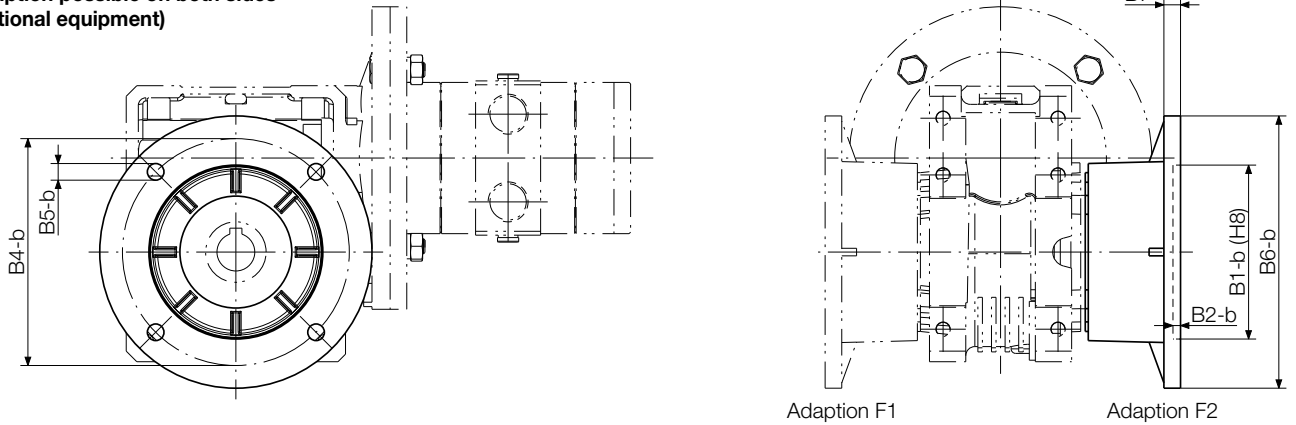

Flange FC
Adaption possible on both sides
(optional equipment)

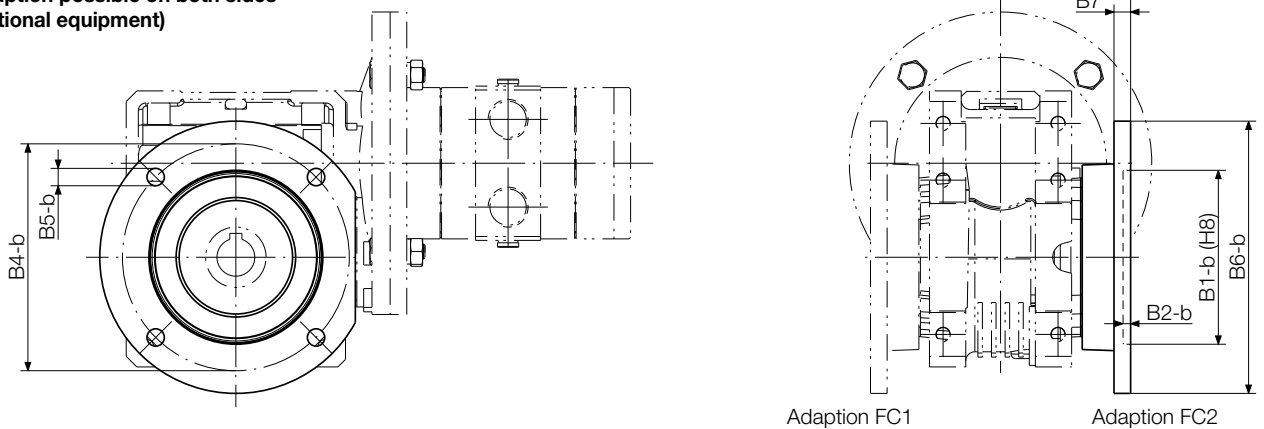

3.2 kW POWER LINE motors with worm gears

The motors in this design series can be operated in either right- or left rotation. Alternatively, the motor can also be reversed by two external 3/2-way valves or one 5/3-way valve.

Motor size 11 with worm gear		Flange motor	Bracket motor
Motor, reversible	Type Part no.	68-W080F1- . . . -11 444886A-F ¹⁾ 68-W080F2- . . . -11 444886G-M ¹⁾	68-W080KA- . . . -11 444890A-F ¹⁾
Nominal power	kW / HP	3.2 / 4.3	3.2 / 4.3
Nominal speed	rpm	44	44
Speed (idling)	rpm	62 ²⁾	62 ²⁾
Nominal torque	Nm / in.lbs	508 / 4496	508 / 4496
Start torque min.	Nm / in.lbs	365 / 3230	365 / 3230
Air consumption	m ³ /min / cfm	3.9 / 137.7	3.9 / 137.7
Weight	kg / lbs	63 / 138.6	63 / 138.6
Hose I.D., supply air/exhaust air	mm / in.	19/ ³ / ₄ / 25/ ⁶³ / ₆₄	19/ ³ / ₄ / 25/ ⁶³ / ₆₄
Gear type		W130F	W130K
Max. gear torque for permanent load	Nm / in.lbs	660 / 5841	660 / 5841

Performance data relate to an air pressure of 6 bar (85 PSI) and lubricated air

¹⁾ F1: A / B / C / D / E / F = mounting position 0B3 / 0B6 / 0B7 / 0B8 / 0V5 / 0V6
 F2: G / H / I / K / L / M = mounting position 0B3 / 0B6 / 0B7 / 0B8 / 0V5 / 0V6
 (Example: mounting position 0B6 = Part no. XXXXXX B)
²⁾ max. admissible speed (idling)

Optional equipment

Spare parts kit	Part no.
	445034B

▶ Mounting positions on page 38	▶ Permissible radial and axial forces on page 41	▶ Spindle designs on page 41	▶ Silencer on page 42
▶ Maintenance unit on page 44	▶ Model number description on page 46		

Design with flange F2
i.e. 68-W080F2-OB3-11

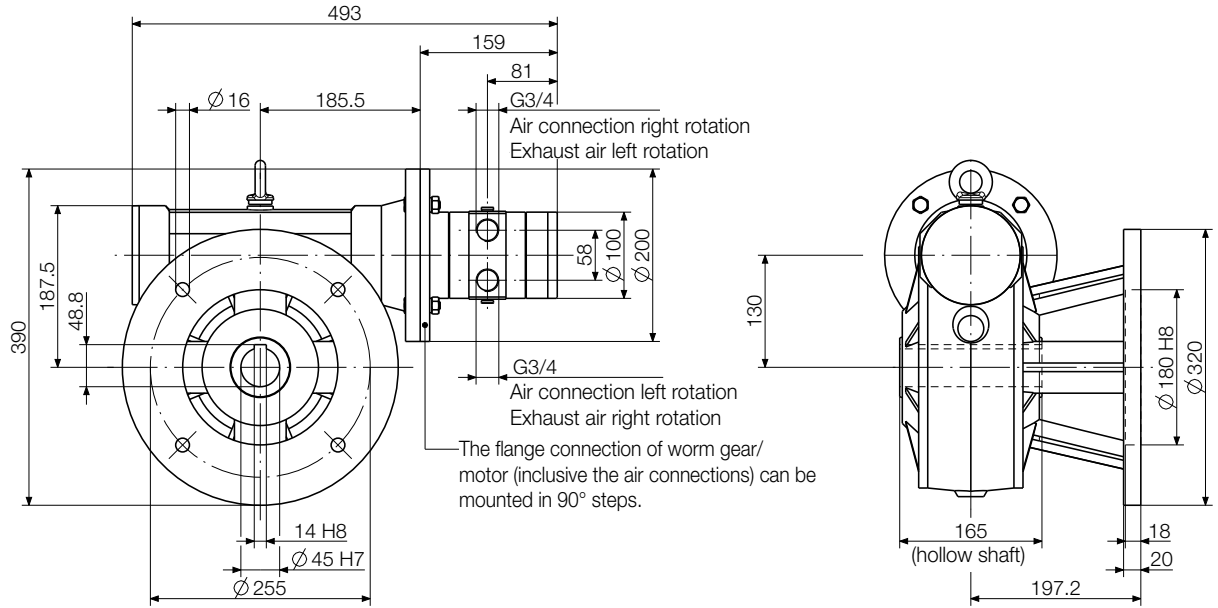

Design with flange F1
i.e. 68-W080F1-OB3-11

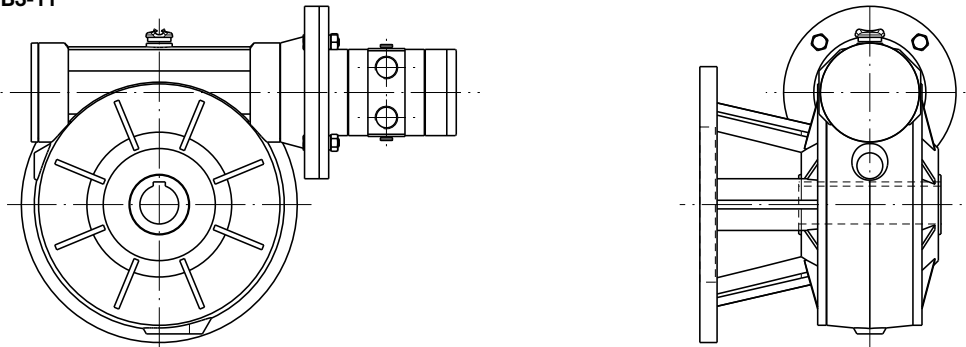

Design with bracket
i.e. 68-W080KA-OB3-11

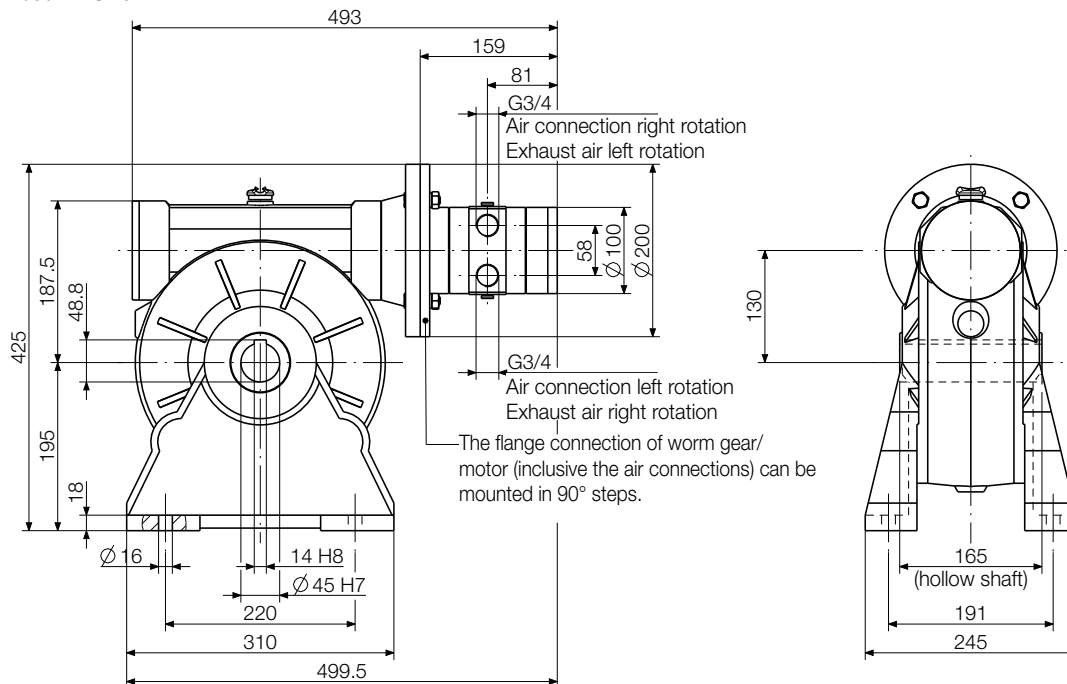

3.2 kW POWER LINE motors with spur gears

The motors in this design series can be operated in either right- or left rotation. Alternatively, the motor can also be reversed by two external 3/2-way valves or one 5/3-way valve.

Motor size 11 with spur gear		Flange motor					
Motor, reversible	Type	68-S006	68-S010	68-S020	68-S045	68-S093	68-S150
	Part no.	F-...-11 444871A-C 1)	F-...-11 444872A-C 1)	F-...-11 444873A-C 1)	F-...-11 444874A-C 1)	F-...-11 446244A-C 1)	F-...-11 446245A-C 1)
Nominal power	kW / HP	3.2 / 4.3	3.2 / 4.3	3.2 / 4.3	3.2 / 4.3	3.2 / 4.3	3.2 / 4.3
Nominal speed	rpm	565	365	175	80	40	20
Speed (idling)	rpm	800 2)	520 2)	250 2)	110 2)	55 2)	30 2)
Nominal torque	Nm / in.lbs	51 / 451.4	79.5 / 703.6	165 / 1460	362 / 3204	710 / 6284	1420 / 12567
Start torque min.	Nm / in.lbs	77 / 681.5	119 / 1053	248 / 2195	544 / 4814	1065 / 9425	2130 / 18850
Permissible radial force max.	N / lbs	660 / 147.8	1750 / 392	3290 / 737	5130 / 1149	10000 / 2240	16000 / 3584
Permissible axial force max.	N / lbs	132 / 29.6	350 / 78.4	658 / 147.4	1026 / 230	2000 / 448	3200 / 716.8
Air consumption	m ³ /min / cfm	3.9 / 137.7	3.9 / 137.7	3.9 / 137.7	3.9 / 137.7	3.9 / 137.7	3.9 / 137.7
Weight	kg / lbs	17.3 / 38	18.3 / 40.3	20.3 / 44.7	39.3 / 86.5	60.5 / 133.1	76 / 167.2
Hose I.D., supply air/exhaust air	mm / in.	19 ³ / ₄ / 25 ⁶³ / ₆₄	19 ³ / ₄ / 25 ⁶³ / ₆₄	19 ³ / ₄ / 25 ⁶³ / ₆₄	19 ³ / ₄ / 25 ⁶³ / ₆₄	19 ³ / ₄ / 25 ⁶³ / ₆₄	19 ³ / ₄ / 25 ⁶³ / ₆₄
Gear type		S122F	S222F	S322F	S412F	S513F	S613F
Max. gear torque for permanent load	Nm / in.lbs	42 / 371.7	115 / 1018	235 / 2080	500 / 4425	1000 / 8850	1600 / 14160

Performance data relate to an air pressure of 6 bar (85 PSI) and lubricated air

1) A / B / C = mounting position 0B5 / 0V1 / 0V3
(Example: mounting position 0V1 = Part no. XXXXXX B)
2) max. admissible speed (idling)

Motor size 11 with spur gear		Bracket motor					
Motor, reversible	Type	68-S006	68-S010	68-S020	68-S045	68-S093	68-S150
	Part no.	K-...-11 444877A-F 1)	K-...-11 444878A-F 1)	K-...-11 444879A-F 1)	K-...-11 444880A-F 1)	K-...-11 446246A-F 1)	K-...-11 446247A-F 1)
Nominal power	kW / HP	3.2 / 4.3	3.2 / 4.3	3.2 / 4.3	3.2 / 4.3	3.2 / 4.3	3.2 / 4.3
Nominal speed	rpm	565	365	175	80	40	20
Speed (idling)	rpm	800 2)	520 2)	250 2)	110 2)	55 2)	30 2)
Nominal torque	Nm / in.lbs	51 / 451.4	79.5 / 703.6	165 / 1460	362 / 3204	710 / 6284	1420 / 12567
Start torque min.	Nm / in.lbs	77 / 681.5	119 / 1053	248 / 2195	544 / 4814	1065 / 9425	2130 / 18850
Permissible radial force max.	N / lbs	660 / 147.8	1750 / 392	3290 / 737	5130 / 1149	10000 / 2240	16000 / 3584
Permissible axial force max.	N / lbs	132 / 29.6	350 / 78.4	658 / 147.4	1026 / 230	2000 / 448	3200 / 716.8
Air consumption	m ³ /min / cfm	3.9 / 137.7	3.9 / 137.7	3.9 / 137.7	3.9 / 137.7	3.9 / 137.7	3.9 / 137.7
Weight	kg / lbs	17.3 / 38	18.3 / 40.3	20.3 / 44.7	39.3 / 86.5	60.5 / 133.1	76 / 167.2
Hose I.D., supply air/exhaust air	mm / in.	19 ³ / ₄ / 25 ⁶³ / ₆₄	19 ³ / ₄ / 25 ⁶³ / ₆₄	19 ³ / ₄ / 25 ⁶³ / ₆₄	19 ³ / ₄ / 25 ⁶³ / ₆₄	19 ³ / ₄ / 25 ⁶³ / ₆₄	19 ³ / ₄ / 25 ⁶³ / ₆₄
Gear type		S122K	S222K	S322K	S412K	S513K	S613K
Max. gear torque for permanent load	Nm / in.lbs	42 / 371.7	115 / 1018	235 / 2080	500 / 4425	1000 / 8850	1600 / 14160

Performance data relate to an air pressure of 6 bar (85 PSI) and lubricated air

1) A / B / C / D / E / F = mounting position 0B3 / 0B6 / 0B7 / 0B8 / 0V5 / 0V6
(Example: mounting position 0B7 = Part no. XXXXXX C)
2) max. admissible speed (idling)

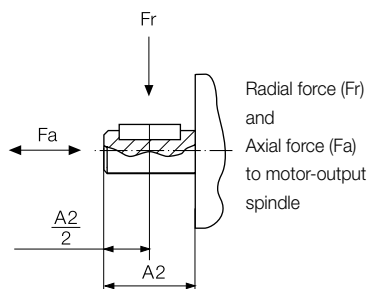

Optional equipment

Spare parts kit	Part no.	445034B
-----------------	----------	---------

▶ **Mounting positions**
on page 39

▶ **Silencer**
on page 42

▶ **Maintenance unit**
on page 44

▶ **Model number description**
on page 46

Flange motor
i.e. 68-S006F-OB3-11

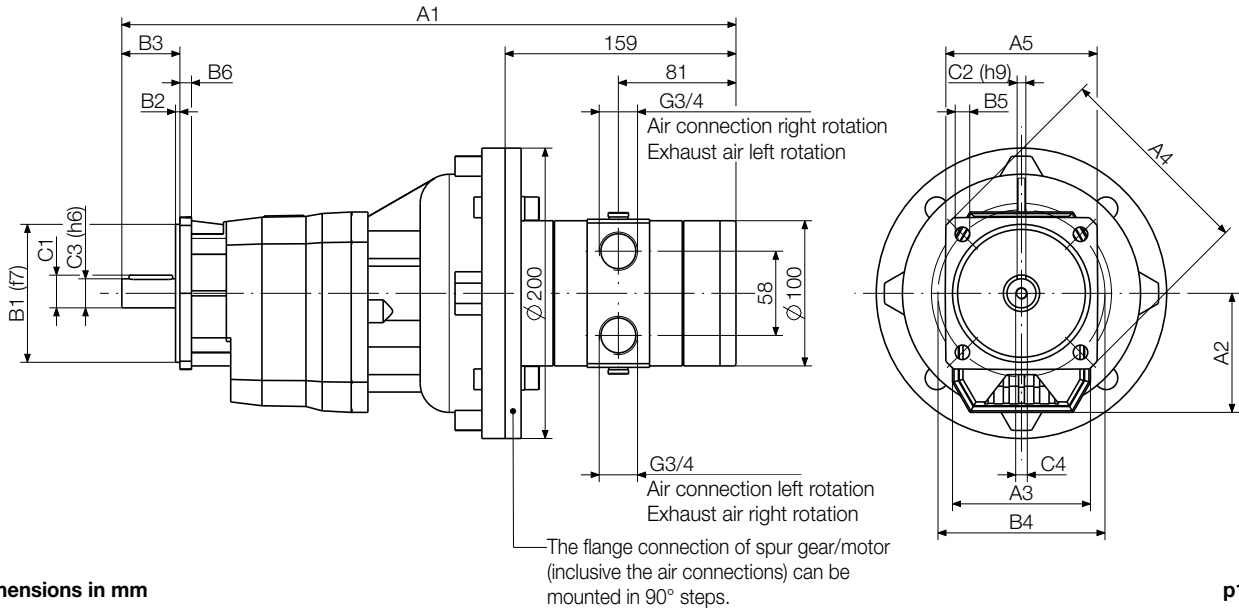

Dimensions in mm

p107204

Motor size 11

Type	Dimensions flange motor (mm)														
	A1	A2	A3	A4	A5	B1	B2	B3	B4	B5	B6	C1	C2	C3	C4
68-S006	423	82	95	140	□105	95	3	40	115	9.5	8	22.5	6	20	M8x19
68-S010	451	94	110	160	□110	110	3.5	50	130	10	10	28	8	25	M8x19
68-S020	486	108	130	200	□150	130	3.5	60	165	11.5	12	33	10	30	M10x22
68-S045	515	128	155	250	-	180	4	70	215	14	13	38	10	35	M10x22
68-S093	541	152	185	300	-	230	4	80	265	14	16	43	12	40	M12x28
68-S150	594	178.5	210	350	-	250	5	100	300	18	18	53.5	14	50	M16x36

Bracket motor
i.e. 68-S006K-OB3-11

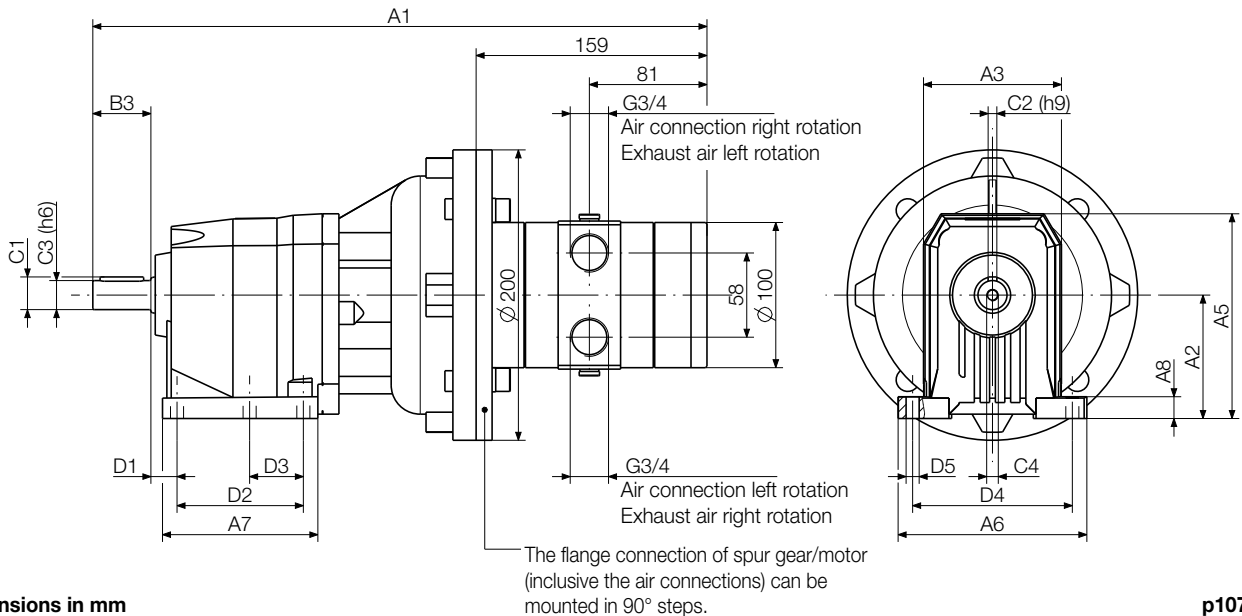

Dimensions in mm



p107204

Motor size 11

Type	Dimensions bracket motor (mm)																
	A1	A2	A3	A5	A6	A7	A8	B3	C1	C2	C3	C4	D1	D2	D3	D4	D5
68-S006	423	85	95	141	130	107	15	40	22.5	6	20	M8x19	18	87	37	110	9
68-S010	451	100	110	166	155	137	17	50	28	8	25	M8x19	18	107.5	47.5	130	11
68-S020	486	110	130	181	190	156	20	60	33	8	30	M10x22	19.5	130	60	160	11
68-S045	515	130	155	223	216	185.5	18	70	38	10	35	M10x22	19.5	149.5	-	180	14
68-S093	541	155	185	278	270	200	22	80	43	12	40	M12x28	25	156	-	225	18
68-S150	594	195	210	316	300	232	25	100	53.5	14	50	M16x36	25	180	-	250	18

5 kW POWER LINE motors

The motors in this design series can be operated in either right- or left rotation. Alternatively, the motor can also be reversed by two external 3/2-way valves or one 5/3-way valve.

Motor size 13		Flange motor reversible				
ATEX conform		Type	68X-001F13/IEC90	68X-002F13/IEC100	68X-004F13/IEC100	68X-001F13/IEC90-VA
		Part no.	without gear 440906B	spur gear 440905B	planetary gear 440904B	stainless design 110013A
ATEX certification			D	D	D	D
Nominal power	kW/HP		5 / 6.7	5 / 6.7	5 / 6.7	5 / 6.7
Nominal speed	rpm		3000	1500	725	3000
Speed (idling)	rpm		6000	3000	1450	6000
Nominal torque	Nm/in.lbs		15.9 / 140.7	32 / 283.2	66 / 584.1	15.9 / 140.7
Start torque min.	Nm/in.lbs		23.9 / 211.5	48 / 424.8	99 / 876	23.9 / 211.5
Stall torque	Nm/in.lbs		30.2 / 267.27	60.5 / 535.4	124.3 / 1100	30.2 / 267.27
Permissible radial force max.	N/lbs		320 / 71.68	1500 / 336	2100 / 470.4	180 / 40.32
Permissible axial force max.	N/lbs		300 / 67.2	760 / 170.24	630 / 141.12	250 / 56
Air consumption	m ³ /min/cfm		5.8 / 204.7	5.8 / 204.7	5.8 / 204.7	5.8 / 204.7
Weight	kg/lbs		17 / 37.4	26 / 57.2	26.9 / 59.18	18,35 / 40.37
Hose I.D., supply air/exhaust air	mm/in.		25 ⁶³ /64 / 32/1 ¹⁷ /64	25 ⁶³ /64 / 32/1 ¹⁷ /64	25 ⁶³ /64 / 32/1 ¹⁷ /64	25 ⁶³ /64 / 32/1 ¹⁷ /64
Motor size 13 with holding brake		Flange motor reversible				
ATEX conform		Type	68X-001F13B/IEC90	68X-002F13B/IEC100	68X-004F13B/IEC100	
		Part no.	without gear 444974C	spur gear 440656B	planetary gear 444974D	
ATEX certification			D	D	D	
without ATEX authorization			68-001F13B/IEC80	68-002F13B/IEC100	68-004F13B/IEC100	
			without gear 110913A	spur gear 110913B	planetary gear 110913C	
Nominal power	kW/HP		5 / 6.7	5 / 6.7	5 / 6.7	
Nominal speed	rpm		3000	1500	725	
Speed (idling)	rpm		6000	3000	1450	
Nominal torque	Nm/in.lbs		15.9 / 140.7	32 / 283.2	66 / 584.1	
Start torque min.	Nm/in.lbs		23.9 / 211.5	48 / 424.8	99 / 876	
Stall torque	Nm/in.lbs		30.2 / 267.27	60.5 / 535.4	124.3 / 1100	
Brake torque	Nm/in.lbs		31.8 / 281.43	64 / 566.4	132 / 1168.2	
Permissible radial force max.	N/lbs		320 / 71.68	1500 / 336	2100 / 470.4	
Permissible axial force max.	N/lbs		300 / 67.2	760 / 170.24	630 / 141.12	
Air consumption	m ³ /min/cfm		5.8 / 204.7	5.8 / 204.7	5.8 / 204.7	
Weight	kg/lbs		17 / 37.4	26 / 57.2	26.9 / 59.18	
Hose I.D., supply air/exhaust air	mm/in.		25 ⁶³ /64 / 32/1 ¹⁷ /64	25 ⁶³ /64 / 32/1 ¹⁷ /64	25 ⁶³ /64 / 32/1 ¹⁷ /64	

Performance data relate to an air pressure of 6 bar (85 PSI) and lubricated air

Optional equipment

Spare parts kit	Part no.	445035B	445035D	445035E	107872A
Spare parts kit for brake	Part no.	445035B	445035D	445035E	-

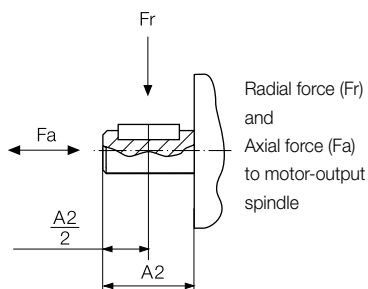

Holding brake (not ATEX conform) on page 40

Silencer on page 42

Maintenance unit on page 44

Model number description on page 46

68(X)-001F13(B)/IEC90
68(X)-001F15(B)/IEC90

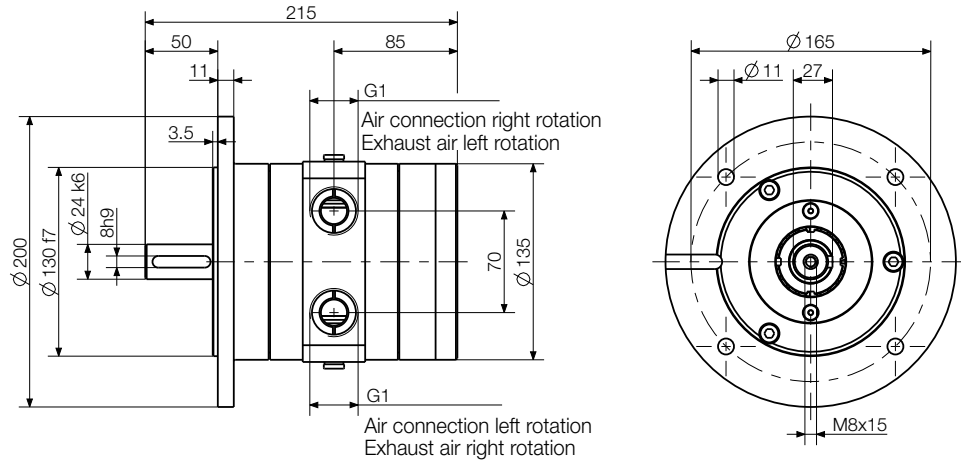

68(X)-002F13(B)/IEC100
68(X)-002F15(B)/IEC100

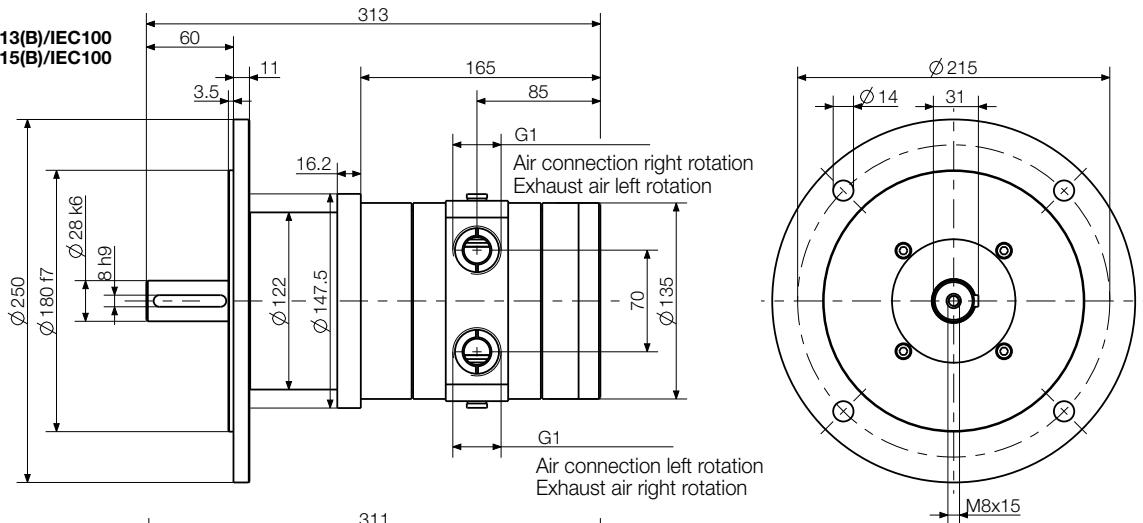

68(X)-004F13(B)/IEC100
68(X)-004F15(B)/IEC100

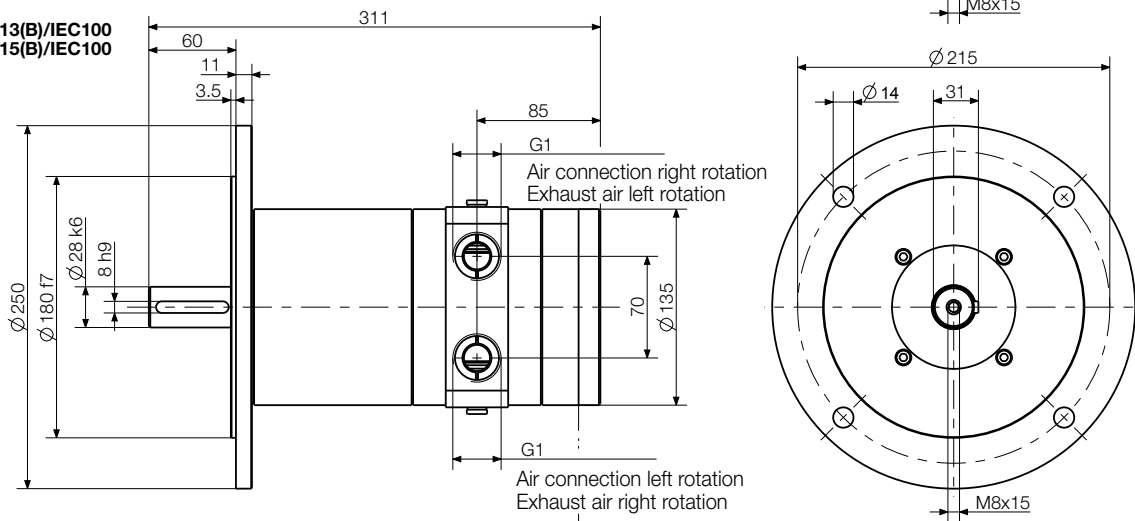

Braking system
446062C

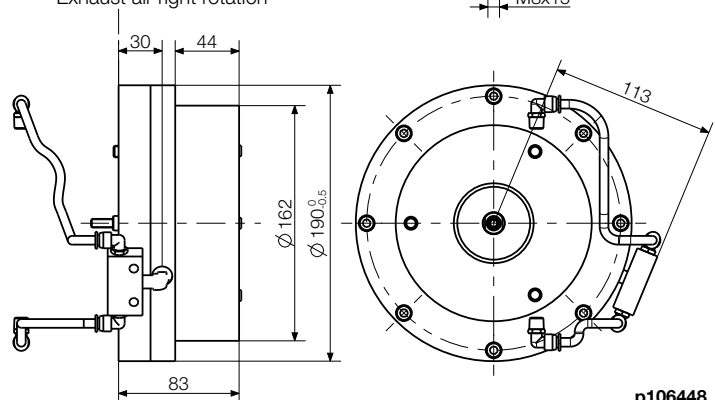

Dimensions in mm

p106448

5 kW POWER LINE motors with worm gears

The motors in this design series can be operated in either right- or left rotation. Alternatively, the motor can also be reversed by two external 3/2-way valves or one 5/3-way valve.

Motor size 13 with worm gear		Universal mounting		
Motor, reversible	Type Part no.	68-W010U-...-13 102922A-F ¹⁾	68-W023U-...-13 102924A-F ¹⁾	68-W040U-...-13 446232A-F ¹⁾
Nominal power	kW / HP	5.0 / 6.7	5.0 / 6.7	5.0 / 6.7
Nominal speed	rpm	300	130	75
Speed (idling)	rpm	500 ²⁾	220 ²⁾	125 ²⁾
Nominal torque	Nm / in.lbs	143 / 1265.5	315 / 2788	509 / 4505
Start torque min.	Nm / in.lbs	160 / 1416	325 / 2876	439 / 3885
Air consumption	m ³ /min / cfm	5.8 / 204.7	5.8 / 204.7	5.8 / 204.7
Weight	kg / lbs	26.6 / 58.5	45 / 99	48 / 105.6
Hose I.D., supply air/exhaust air	mm / in.	25/ ⁶³ / ₆₄ / 32/ ¹¹⁷ / ₆₄	25/ ⁶³ / ₆₄ / 32/ ¹¹⁷ / ₆₄	25/ ⁶³ / ₆₄ / 32/ ¹¹⁷ / ₆₄
Gear type		W75U	W110U	W110U
Max. gear torque for permanent load	Nm / in.lbs	205 / 1814	480 / 4248	595 / 5266

Performance data relate to an air pressure of 6 bar (85 PSI) and lubricated air

¹⁾ A / B / C / D / E / F = mounting position 0B3 / 0B6 / 0B7 / 0B8 / 0V5 / 0V6
(Example: mounting position 0B6 = Part no. XXXXXX B)
²⁾ max. admissible speed (idling)

Using the universal mounting the motor can be fixed flexibly. As well as direct mounting, indirect mounting via a flange (F/FC) is also possible.

Optional equipment		
Spare parts kit	Part no.	445035B
Flange	Part no.	see on page 41

Motor size 13																				
Type	Dimensions (mm)																			
	A1	A2	A3	A4	A5	A6	B1-a	B1-b	B2-a	B2-b	B3-a	B3-b	B3-c	B4-a	B4-b	B5-a	B5-b	B6-a	B6-b	
68-W010U	364	220.5	174	87	87	75	90	130	3	5	61.5	111	85	110	165	M8x14	12.5	125	200	
68-W023U	433	308	250	125	125	110.1	130	170	3.5	12	76.5	179.5	131.5	165	230	M12x19	13	200	280	
68-W040U																				
	B7	C1	C2	C3	C4	D1	D2	D3	D4	D5	D6	D7	D8							
68-W010U	12	33.3	8	30	127	126	126	46.5	82	109.5	46.5	9	10.5							
68-W023U	20	45.3	12	42	155	184	184	58	115	174	82	14	14							
68-W040U																				

▶ Spindle designs on page 41	▶ Permissible radial and axial forces on page 41	▶ Flange designs F/FC on page 41	▶ Silencer on page 42
▶ Maintenance unit on page 44	▶ Model number description on page 46		

Standard design without flange
 i.e. 68-W010U-OB3-13

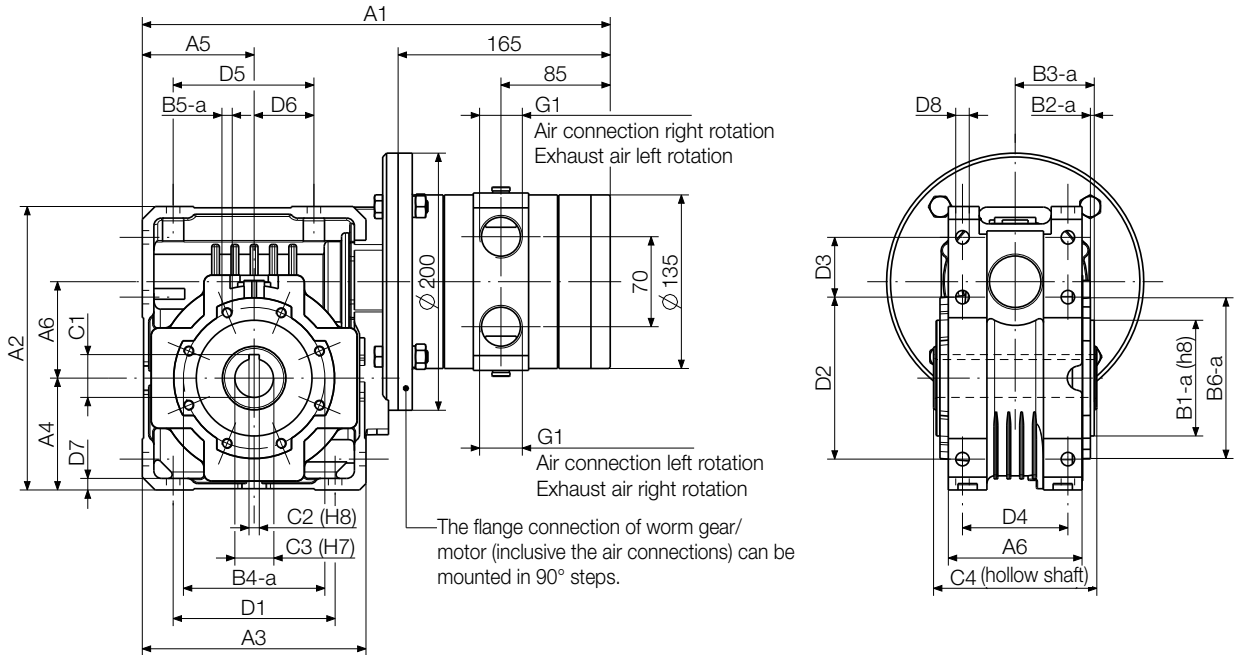

Flange F
 Adaption possible on both sides
 (optional equipment)

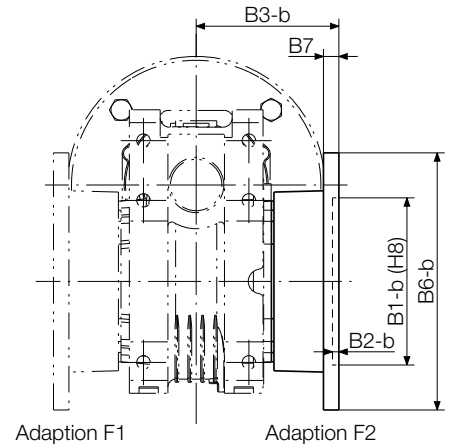
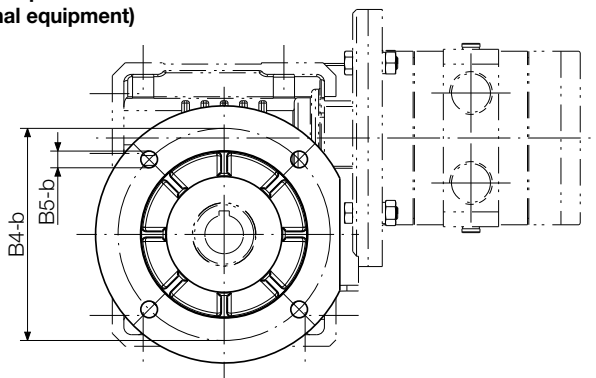

Flange FC
 Adaption possible on both sides
 (optional equipment)

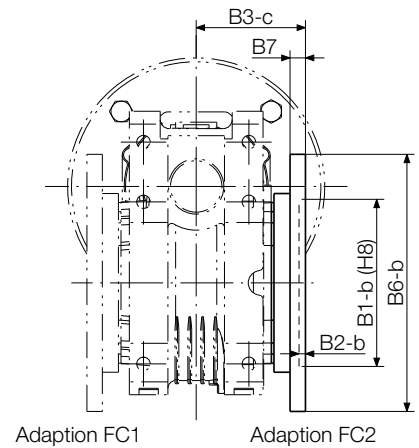
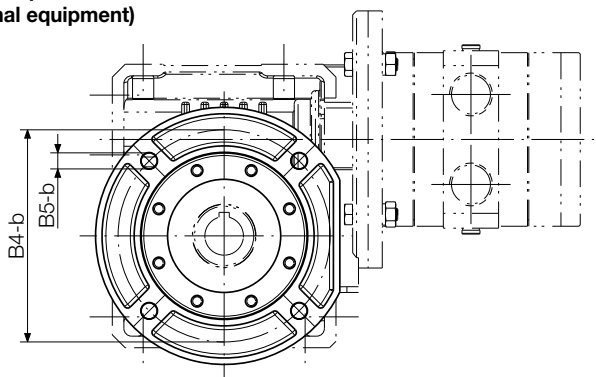

Dimensions in mm

p107384

5 kW POWER LINE motors with worm gears

The motors in this design series can be operated in either right- or left rotation. Alternatively, the motor can also be reversed by two external 3/2-way valves or one 5/3-way valve.

Motor size 13 with worm gear		Flange motor	Bracket motor
Motor, reversible	Type Part no.	68-W090F1-...-13 102933A-F ¹⁾ 68-W090F2-...-13 102933G-M ¹⁾	68-W090KA-...-13 102935A-F ¹⁾
Nominal power	kW / HP	5.0 / 6.7	5.0 / 6.7
Nominal speed	rpm	37	37
Speed (idling)	rpm	55 ²⁾	55 ²⁾
Nominal torque	Nm / in.lbs	980 / 8673	980 / 8673
Start torque min.	Nm / in.lbs	930 / 8230	930 / 8230
Air consumption	m ³ /min / cfm	5.8 / 204.7	5.8 / 204.7
Weight	kg / lbs	79 / 173.8	79 / 173.8
Hose I.D., supply air/exhaust air	mm / in.	25/ ⁶³ / ₆₄ / 32/ ¹⁷ / ₆₄	25/ ⁶³ / ₆₄ / 32/ ¹⁷ / ₆₄
Gear type		WR130F	WR130A
Max. gear torque for permanent load	Nm / in.lbs	1250 / 11062	1250 / 11062

Performance data relate to an air pressure of 6 bar (85 PSI) and lubricated air

¹⁾ F1: A / B / C / D / E / F = mounting position 0B3 / 0B6 / 0B7 / 0B8 / 0V5 / 0V6
F2: G / H / I / K / L / M = mounting position 0B3 / 0B6 / 0B7 / 0B8 / 0V5 / 0V6
(Example: mounting position 0B6 = Part no. XXXXXX B)
²⁾ max. admissible speed (idling)

Optional equipment		
Spare parts kit	Part no.	445035B

▶ Mounting positions on page 38	▶ Permissible radial and axial forces on page 41	▶ Spindle designs on page 41	▶ Silencer on page 42
▶ Maintenance unit on page 44	▶ Model number description on page 46		

Design with flange F2
i.e. 68-W090F2-OB3-13

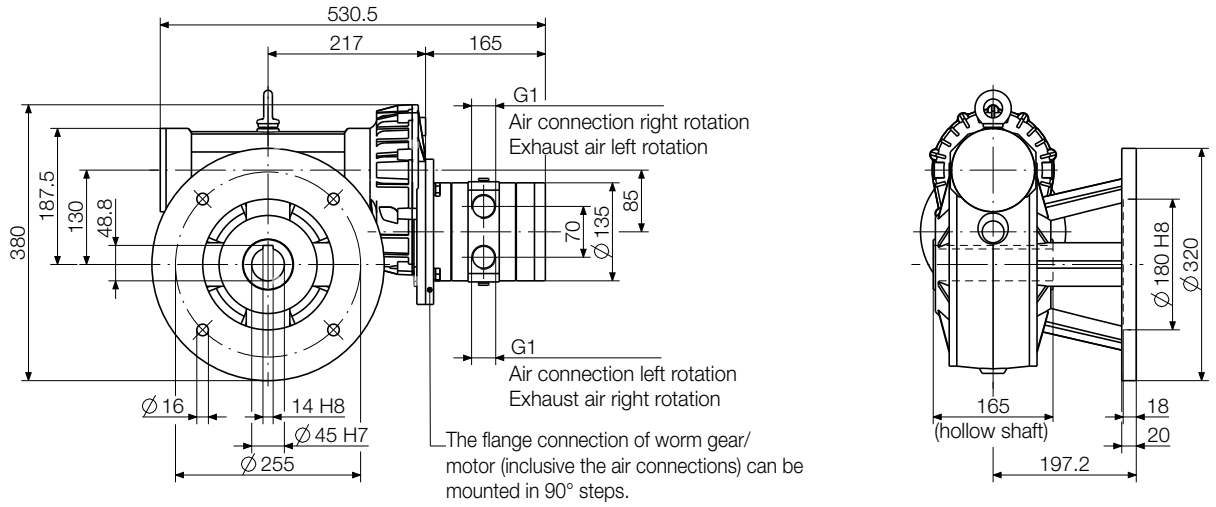

Design with flange F1
i.e. 68-W090F1-OB3-13

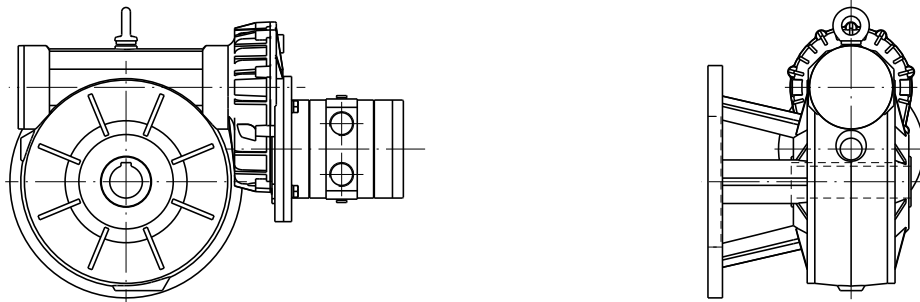

Design with bracket
i.e. 68-W090KA-OB3-13

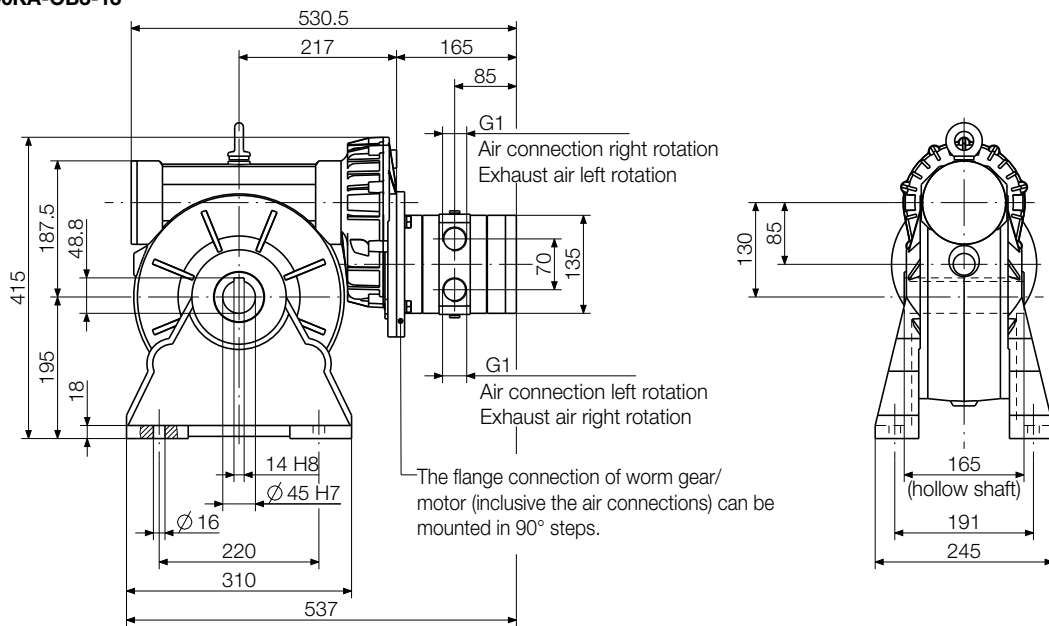

5 kW POWER LINE motors with spur gears

The motors in this design series can be operated in either right- or left rotation. Alternatively, the motor can also be reversed by two external 3/2-way valves or one 5/3-way valve.

Motor size 13 with spur gear		Flange motor					
Motor, reversible	Type	68-S005 F-...-13	68-S010 F-...-13	68-S020 F-...-13	68-S040 F-...-13	68-S083 F-...-13	68-S169 F-...-13
	Part no.	444891A-C ¹⁾	444892A-C ¹⁾	444893A-C ¹⁾	444894A-C ¹⁾	444895A-C ¹⁾	444896A-C ¹⁾
Nominal power	kW / HP	5.0 / 6.7	5.0 / 6.7	5.0 / 6.7	5.0 / 6.7	5.0 / 6.7	5.0 / 6.7
Nominal speed	rpm	625	310	150	74	36	18
Speed (idling)	rpm	1050 ²⁾	520 ²⁾	250 ²⁾	125 ²⁾	60 ²⁾	30 ²⁾
Nominal torque	Nm / in.lbs	72 / 637.2	146 / 1292	302 / 2673	612 / 5416	1230 / 10885	2460 / 21771
Start torque min.	Nm / in.lbs	108 / 956	220 / 1947	450 / 3982	920 / 8142	1850 / 16372	3700 / 32745
Permissible radial force max.	N / lbs	1370 / 307	2580 / 578	3880 / 869	8870 / 1987	14500 / 3248	35000 / 7840
Permissible axial force max.	N / lbs	274 / 61	516 / 116	776 / 174	1770 / 396	2900 / 650	7000 / 1568
Air consumption	m ³ /min / cfm	5.8 / 204.7	5.8 / 204.7	5.8 / 204.7	5.8 / 204.7	5.8 / 204.7	5.8 / 204.7
Weight	kg / lbs	24.6 / 54	27 / 59.4	46 / 101.2	67.2 / 147.8	82.5 / 181.5	164 / 360.8
Hose I.D., supply air/exhaust air	mm / in.	25 ⁶³ / ₆₄ / 32 ¹¹⁷ / ₆₄	25 ⁶³ / ₆₄ / 32 ¹¹⁷ / ₆₄	25 ⁶³ / ₆₄ / 32 ¹¹⁷ / ₆₄	25 ⁶³ / ₆₄ / 32 ¹¹⁷ / ₆₄	25 ⁶³ / ₆₄ / 32 ¹¹⁷ / ₆₄	25 ⁶³ / ₆₄ / 32 ¹¹⁷ / ₆₄
Gear type		S222F	S322F	S412F	S512F	S613F	S803F
Max. gear torque for permanent load	Nm / in.lbs	80 / 708	175 / 1549	385 / 3407	795 / 7036	1600 / 14160	4000 / 35400

Performance data relate to an air pressure of 6 bar (85 PSI) and lubricated air

¹⁾ A / B / C = mounting position 0B5 / 0V1 / 0V3
(Example: mounting position 0V1 = Part no. XXXXXX B)
²⁾ max. admissible speed (idling)

Motor size 13 with spur gear		Bracket motor					
Motor, reversible	Type	68-S005 K-...-13	68-S010 K-...-13	68-S020 K-...-13	68-S040 K-...-13	68-S083 K-...-13	68-S169 K-...-13
	Part no.	444897A-F ¹⁾	444898A-F ¹⁾	444899A-F ¹⁾	444900A-F ¹⁾	444901A-F ¹⁾	444902A-F ¹⁾
Nominal power	kW / HP	5.0 / 6.7	5.0 / 6.7	5.0 / 6.7	5.0 / 6.7	5.0 / 6.7	5.0 / 6.7
Nominal speed	rpm	625	310	150	74	36	18
Speed (idling)	rpm	1050 ²⁾	520 ²⁾	250 ²⁾	125 ²⁾	60 ²⁾	30 ²⁾
Nominal torque	Nm / in.lbs	72 / 637.2	146 / 1292	302 / 2673	612 / 5416	1230 / 10885	2460 / 21771
Start torque min.	Nm / in.lbs	108 / 956	220 / 1947	450 / 3982	920 / 8142	1850 / 16372	3700 / 32745
Permissible radial force max.	N / lbs	1370 / 307	2580 / 578	3880 / 869	8870 / 1987	14500 / 3248	35000 / 7840
Permissible axial force max.	N / lbs	274 / 61	516 / 116	776 / 174	1770 / 396	2900 / 650	7000 / 1568
Air consumption	m ³ /min / cfm	5.8 / 204.7	5.8 / 204.7	5.8 / 204.7	5.8 / 204.7	5.8 / 204.7	5.8 / 204.7
Weight	kg / lbs	24.6 / 54	27 / 59.4	46 / 101.2	67.2 / 147.8	82.5 / 181.5	164 / 360.8
Hose I.D., supply air/exhaust air	mm / in.	25 ⁶³ / ₆₄ / 32 ¹¹⁷ / ₆₄	25 ⁶³ / ₆₄ / 32 ¹¹⁷ / ₆₄	25 ⁶³ / ₆₄ / 32 ¹¹⁷ / ₆₄	25 ⁶³ / ₆₄ / 32 ¹¹⁷ / ₆₄	25 ⁶³ / ₆₄ / 32 ¹¹⁷ / ₆₄	25 ⁶³ / ₆₄ / 32 ¹¹⁷ / ₆₄
Gear type		S222K	S322K	S412K	S512K	S613K	S803K
Max. gear torque for permanent load	Nm / in.lbs	80 / 708	175 / 1549	385 / 3407	795 / 7036	1600 / 14160	4000 / 35400

Performance data relate to an air pressure of 6 bar (85 PSI) and lubricated air

¹⁾ A / B / C / D / E / F = mounting position 0B3 / 0B6 / 0B7 / 0B8 / 0V5 / 0V6
(Example: mounting position 0B7 = Part no. XXXXXX C)
²⁾ max. admissible speed (idling)

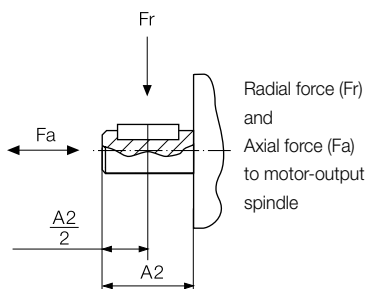

Optional equipment

Spare parts kit	Part no.	445035B
-----------------	----------	---------

Mounting positions
on page 39

Silencer
on page 42

Maintenance unit
on page 44

Model number
description on page 46

Flange motor
i.e. 68-S005F-OB3-13

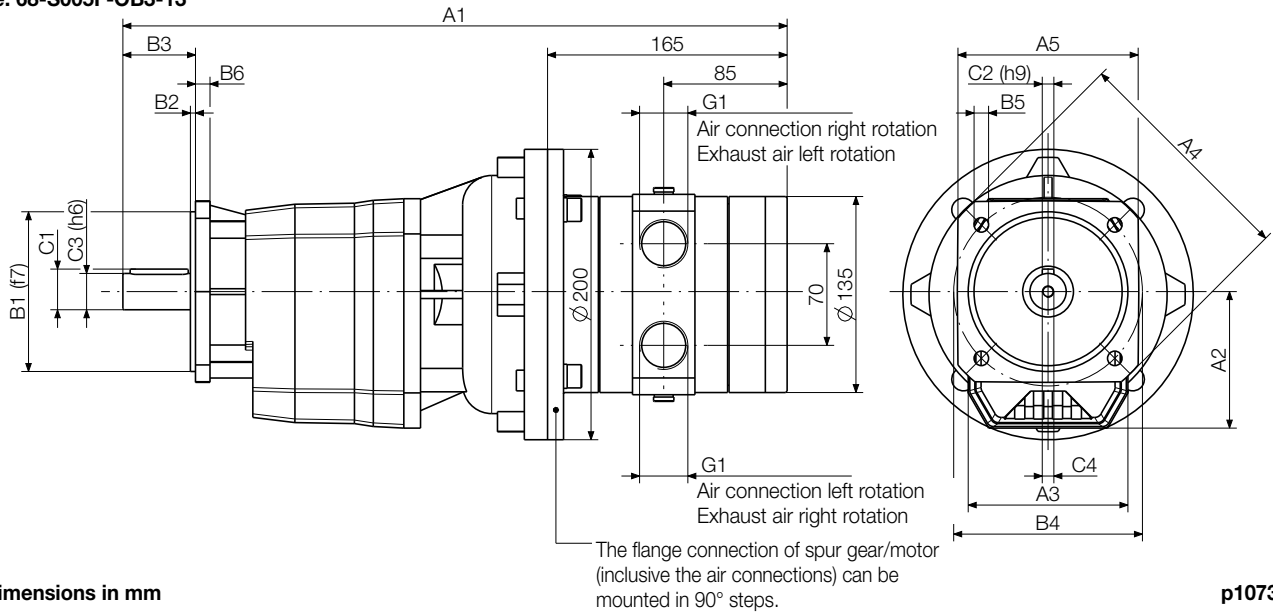

Dimensions in mm

p107326

Motor size 13

Type	Dimensions flange motor (mm)														
	A1	A2	A3	A4	A5	B1	B2	B3	B4	B5	B6	C1	C2	C3	C4
68-S005	458	94	110	160	□110	110	3.5	50	130	9.5	10	28	8	25	M8x19
68-S010	492	108	130	200	□150	130	3.5	60	165	11.5	12	33		30	M10x22
68-S020	521	128	155	250		180	4	70	215	14	13	38	10	35	
68-S040	547	152	185	300	-	230	4	80	265	14	16	43	12	40	M12x28
68-S083	600	178.5	210	350		250	5	100	300	18	18	53.5	14	50	M16x36
68-S169	698	247	320	400	□350	300	5	140	350	18	20	85	22	80	M20x42

Bracket motor
i.e. 68-S005K-OB3-13

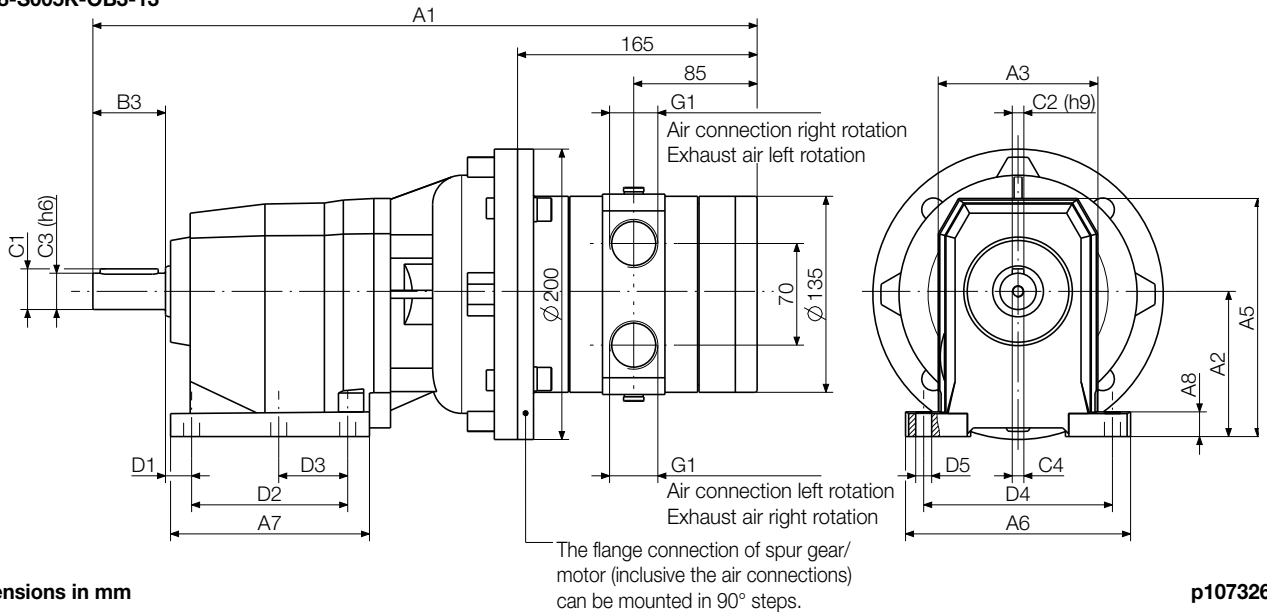

Dimensions in mm



p107326

Motor size 13

Type	Dimensions bracket motor (mm)																		
	A1	A2	A3	A5	A6	A7	A8	B3	C1	C2	C3	C4	D1	D2	D3	D4	D5		
68-S005	458	100	110	166	155	137	17	50	28	8	25	M8x19	18	107.5	47.5	130			
68-S010	492	110	130	181	190	156	20	60	33	8	30	M10x22	18	130	60	160	11		
68-S020	521	130	155	223	216	185.5	18	70	38	10	35	M10x22	19.5	149.5	-	180	14		
68-S040	547	155	185	278	270	200	22	80	43	12	40	M12x28	25	156	-	225	18		
68-S083	600	195	210	316	300	232	25	100	53.5	14	50	M16x36	25	180	-	250	18		
68-S169	698	250	320	420	440	277	35	140	85	22	80	M20x42	33	210	-	370	26		

6 kW POWER LINE motors

The motors in this design series can be operated in either right- or left rotation. Alternatively, the motor can also be reversed by two external 3/2-way valves or one 5/3-way valve.

Motor size 15		Flange motor reversible				
ATEX conform		Type	68X-001F15/IEC90	68X-002F15/IEC100	68X-004F15/IEC100	68X-001F15/IEC90-VA
		Part no.	without gear 4408001A	spur gear 4408001B	planetary gear 4408001C	stainless design 110015A
ATEX certification			D	D	D	D
Nominal power	kW/HP	6 / 8	6 / 8	6 / 8	6 / 8	6 / 8
Nominal speed	rpm	3500	1700	800	3500	3500
Speed (idling)	rpm	7000	3500	1600	7000	7000
Nominal torque	Nm/in.lbs	16.4 / 145	33.7 / 298.2	71 / 628.3	16,4	16,4
Start torque min.	Nm/in.lbs	24.6 / 217.7	50.6 / 447.8	107 / 947	24,6	24,6
Stall torque	Nm/in.lbs	31.1 / 275.2	64 / 566.4	136.10 / 1204.5	31.1 / 275.2	31.1 / 275.2
Permissible radial force max.	N/lbs	270 / 60.5	1400 / 313.6	2000 / 448	140 / 31.36	140 / 31.36
Permissible axial force max.	N/lbs	280 / 62.72	730 / 163.5	600 / 134.4	230 / 51.52	230 / 51.52
Air consumption	m ³ /min/cfm	7.9 / 278.9	7.9 / 278.9	7.9 / 278.9	7,9	7,9
Weight	kg/lbs	17 / 37.4	25.8 / 56.7	26.8 / 59	18,35	18,35
Hose I.D., supply air/exhaust air	mm/in.	25 ⁶³ /64 / 32/1 ¹⁷ /64	25 ⁶³ /64 / 32/1 ¹⁷ /64	25 ⁶³ /64 / 32/1 ¹⁷ /64	25/32	25/32
Motor size 15 with holding brake		Flange motor reversible				
ATEX conform		Type	68X-001F15B/IEC90	68X-002F15B/IEC100	68X-004F15B/IEC100	
		Part no.	without gear 440801A	spur gear 440801B	planetary gear 440801C	
ATEX certification			D	D	D	
without ATEX authorization			68-001F15B/IEC80	68-002F15B/IEC100	68-004F15B/IEC100	
		Part no.	without gear 110915A	spur gear 110915B	planetary gear 110915C	
Nominal power	kW/HP	6 / 8	6 / 8	6 / 8		
Nominal speed	rpm	3500	1700	800		
Speed (idling)	rpm	7000	3500	1600		
Nominal torque	Nm/in.lbs	16.4 / 145	33.7 / 298.2	71 / 628.3		
Start torque min.	Nm/in.lbs	24.6 / 217.7	50.6 / 447.8	107 / 947		
Stall torque	Nm/in.lbs	31.1 / 275.2	64 / 566.4	136.10 / 1204.5		
Brake torque	Nm/in.lbs	32.8 / 290.28	67.4 / 596.5	142 / 1256.7		
Permissible radial force max.	N/lbs	270 / 60.5	1400 / 313.6	2000 / 448		
Permissible axial force max.	N/lbs	280 / 62.72	730 / 163.5	600 / 134.4		
Air consumption	m ³ /min/cfm	7.9 / 278.9	7.9 / 278.9	7.9 / 278.9		
Weight	kg/lbs	17 / 37.4	25.8 / 56.7	26.8 / 59		
Hose I.D., supply air/exhaust air	mm/in.	25 ⁶³ /64 / 32/1 ¹⁷ /64	25 ⁶³ /64 / 32/1 ¹⁷ /64	25 ⁶³ /64 / 32/1 ¹⁷ /64		

Performance data relate to an air pressure of 6 bar (85 PSI) and lubricated air

Optional equipment

Optional equipment	Part no.	445035B	445035D	445035E	107872A
Spare parts kit	Part no.	445035B	445035D	445035E	107872A
Spare parts kit for brake	Part no.	445035B	445035D	445035E	-

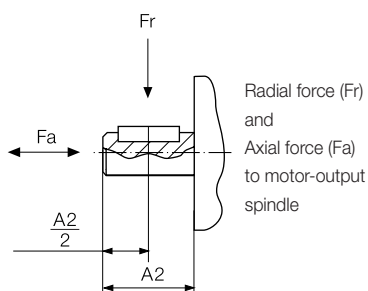

Holding brake (not ATEX conform) on page 40

Silencer on page 42

Maintenance unit on page 44

Model number description on page 46

68(X)-001F13(B)/IEC90
68(X)-001F15(B)/IEC90

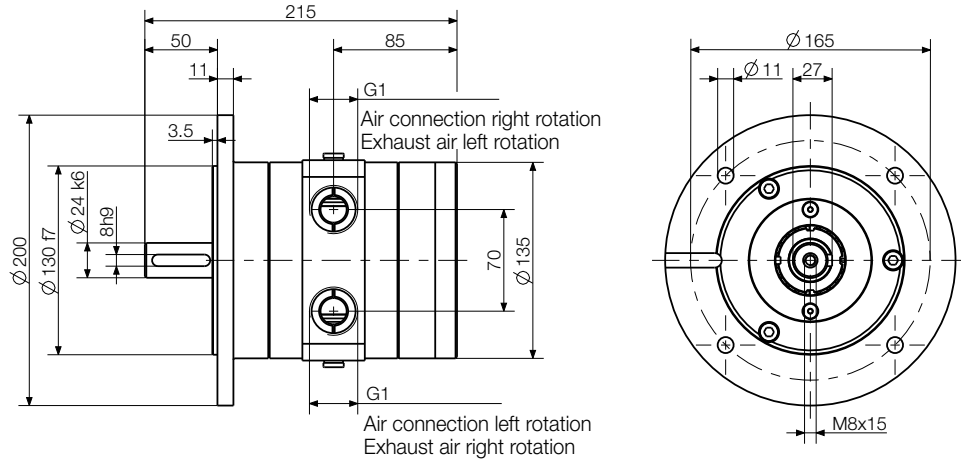

68(X)-002F13(B)/IEC100
68(X)-002F15(B)/IEC100

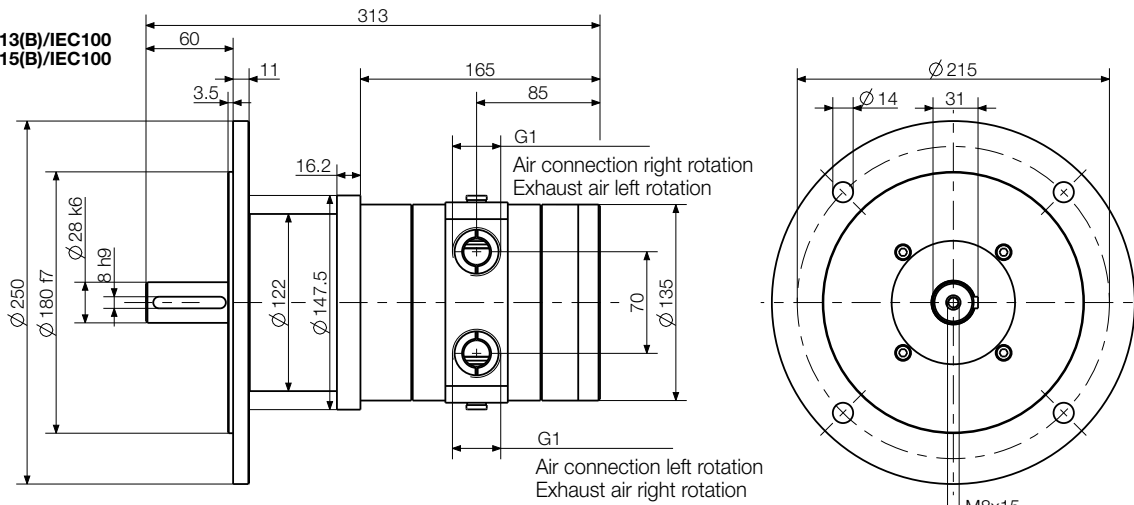

68(X)-004F13(B)/IEC100
68(X)-004F15(B)/IEC100

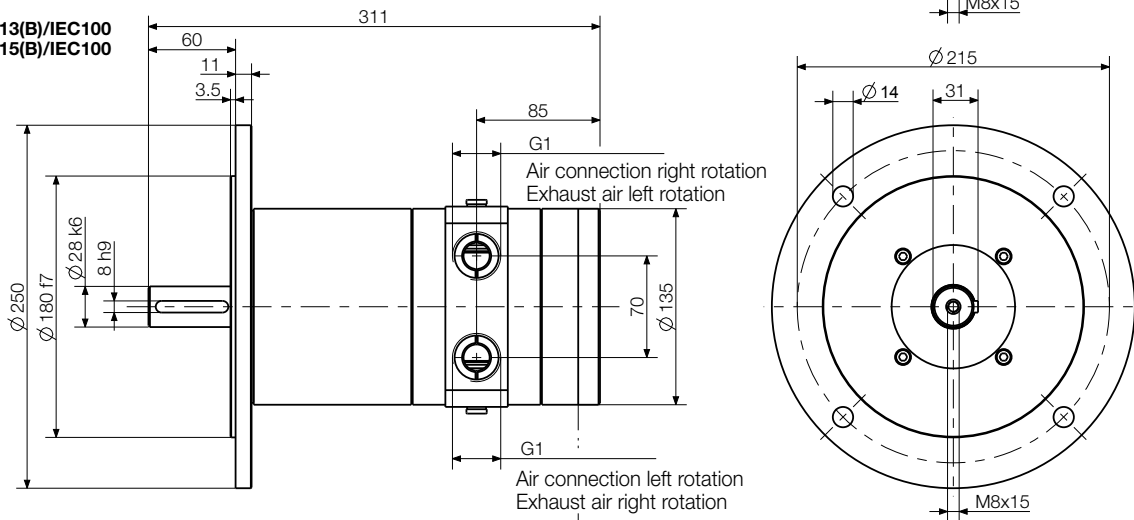

Braking system
446062C

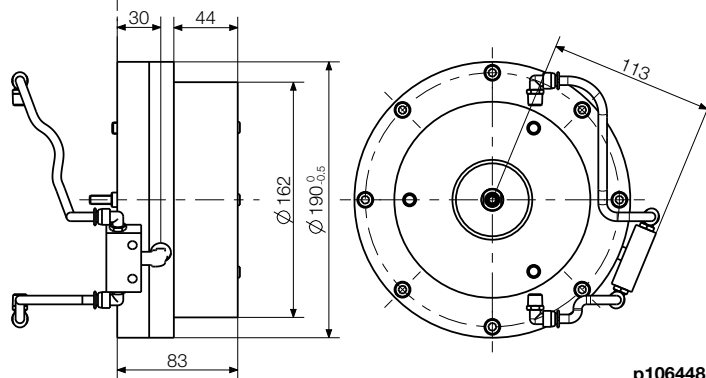

Dimensions in mm

9 kW / 18 kW POWER LINE motors without gears

The motors in this design series can be operated in either right- or left rotation. Alternatively, the motor can also be reversed by two external 3/2-way valves or one 5/3-way valve.

Motor design without gearing		Flange motor	
Motor size		55	65
Motor, reversible		68X-001F55/IEC112A	68X-001F65/IEC112A
Type		123055A	123065A
Part no.		C	C
ATEX certification			
Nominal power	kW / HP	9 / 12	18 / 24
Nominal speed	rpm	3000	3000
Permissible speed max.	rpm	4700	5300
Nominal torque	Nm/in.lbs	28.6 / 253	57 / 504
Start torque min.	Nm/in.lbs	43 / 380	85 / 752
Stall torque	Nm/in.lbs	54 / 478	108 / 955.8
Permissible radial force max.	N / lbs	2200 / 492.8	2400 / 537.6
Permissible axial force max.	N / lbs	700 / 156.8	700 / 156.8
Air consumption	m ³ /min / cfm	10 / 353	20 / 706
Weight	kg / lbs	33 / 72.6	54 / 118.8
Hose I.D., supply air/exhaust air	mm / in.	25 ⁶³ /64 / 32/1 ¹⁷ /64	43/1.68 / 63.5/2.48

Performance data relate to an air pressure of 6 bar (85 PSI) and lubricated air

Optional equipment	Motor size 55	Motor size 65
Bracket	440648	440648
Spare parts kit	440246C	440246B

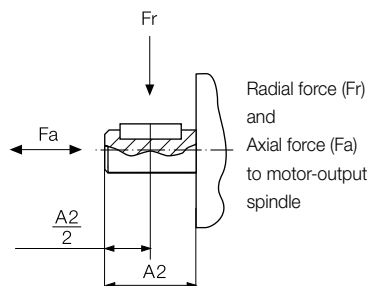

Mounting positions
on page 39

Silencer
on page 42

Maintenance unit
on page 44

Model number description
on page 46

68X-001F55/IEC112A

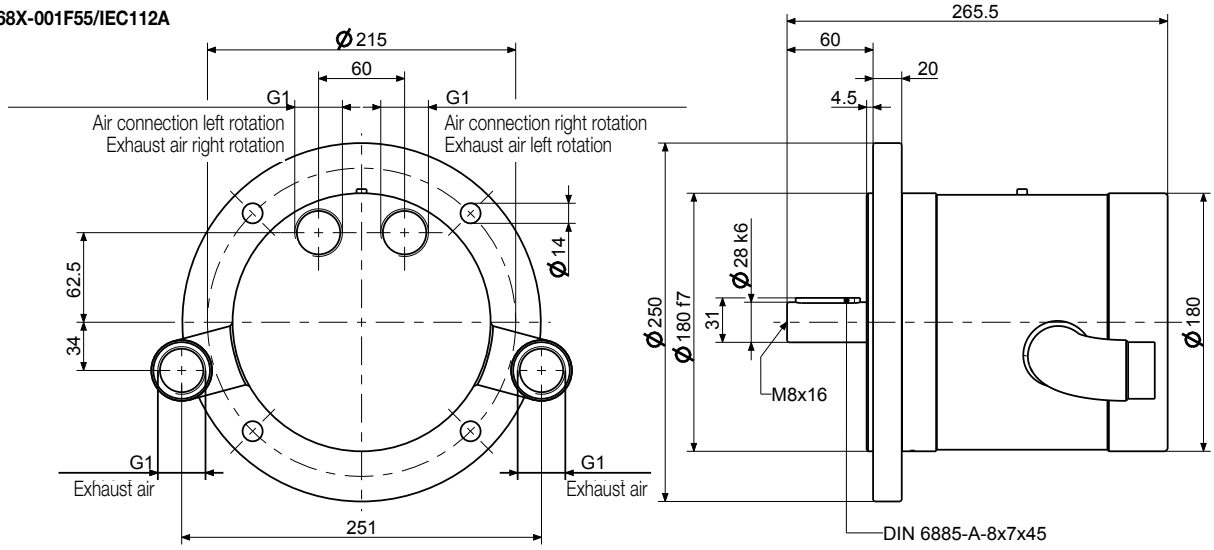

68X-001F65/IEC112A

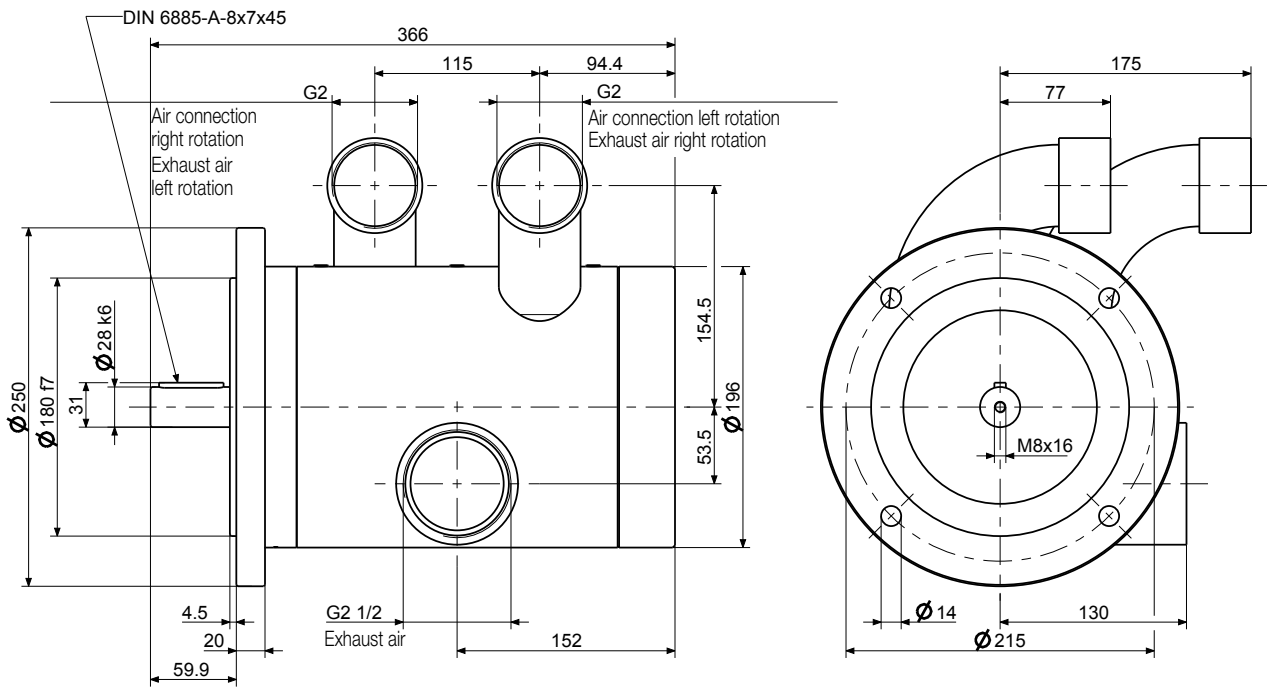

**Bracket
for motor size 55 and 65
(optional equipment)**

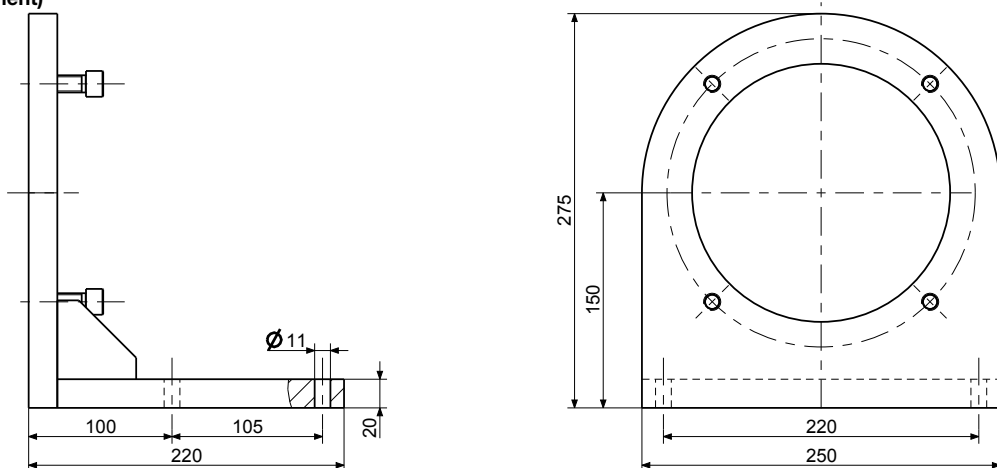

1.9 kW / 3.3 kW / 4.6 kW POWER LINE motors with hand lever valve

The motors in this design series can be operated in either right- or left rotation. Reverse is initiated by the integrated hand lever. Additionally, these motors incorporate a higher power output, when compared with the same design series with 2 air connections.

Motor size 32		Flange motor				Bracket motor			
		without gearing	with planetary gear			without gearing	with planetary gear		
Motor, reversible by integrated hand lever	Type Part no.	FM32SU 441824A	FM32LU 441801A	FM32LLUA 441825A	FM32LLUB 441826A	KM32SU 441868A	KM32LU 441869A	KM32LLUA 441870A	KM32LLUB 441871A
Nominal power	kW / HP	1.9 / 2.5	1.9 / 2.5	1.9 / 2.5	1.9 / 2.5	1.9 / 2.5	1.9 / 2.5	1.9 / 2.5	1.9 / 2.5
Nominal speed	rpm	3400	340	170	100	3400	340	170	100
Speed (idling)	rpm	6800	680	340	200	6800	680	340	200
Nominal torque	Nm / in.lbs	5.3 / 47	53 / 469	107 / 947	181 / 1602	5.3 / 47	53 / 469	107 / 947	181 / 1602
Start torque min.	Nm / in.lbs	7.9 / 70	79 / 699	160 / 1416	271 / 2398	7.9 / 70	79 / 699	160 / 1416	271 / 2398
Air consumption	m ³ /min / cfm	1.9 / 67	1.9 / 67	1.9 / 67	1.9 / 67	1.9 / 67	1.9 / 67	1.9 / 67	1.9 / 67
Weight	kg / lbs	15.8/34.76	18.1/39.82	22.7/49.94	22.5/49.5	17/37.4	19.3/42.46	23.9/52.58	23.7/52.14
Hose I.D., supply air/exhaust air	mm / in.	15 ⁵ / ₈ / 19 ³ / ₄				15 ⁵ / ₈ / 19 ³ / ₄			

Performance data relate to an air pressure of 6 bar (85 PSI) and lubricated air

Optional equipment

Spare parts kit	Part no.	104355A
-----------------	----------	---------

Motor size 50		Flange motor				Bracket motor			
		without gearing	with planetary gear			without gearing	with planetary gear		
Motor, reversible by integrated hand lever	Type Part no.	FM50SU 442135A	FM50LU 441828A	FM50LLUA 442103A	FM50LLUB 442104A	KM50SU 442140A	KM50LU 441873A	KM50LLUA 441874A	KM50LLUB 441875A
Nominal power	kW / HP	3.3 / 4.4	3.2 / 4.3	3.2 / 4.3	3.2 / 4.3	3.3 / 4.4	3.2 / 4.3	3.2 / 4.3	3.2 / 4.3
Nominal speed	rpm	3000	240	100	75	3000	240	100	75
Speed (idling)	rpm	6000	480	200	150	6000	480	200	150
Nominal torque	Nm / in.lbs	10 / 88	127 / 1124	305 / 2699	407 / 3602	10 / 88	127 / 1124	305 / 2699	407 / 3602
Start torque min.	Nm / in.lbs	15 / 133	190 / 1681	458 / 4053	610 / 5398	15 / 133	190 / 1681	458 / 4053	610 / 5398
Air consumption	m ³ /min / cfm	3.6 / 127	3.6 / 127	3.6 / 127	3.6 / 127	3.6 / 127	3.6 / 127	3.6 / 127	3.6 / 127
Weight	kg / lbs	27.8/61.16	32.3/71.06	33.7/74.14	34.1/75	31.5/69.3	33.2/73	42.5/93.5	42.9/94.38
Hose I.D., supply air/exhaust air	mm / in.	19 ³ / ₄ / 25 ⁶³ / ₆₄				19 ³ / ₄ / 25 ⁶³ / ₆₄			

Performance data relate to an air pressure of 6 bar (85 PSI) and lubricated air

Optional equipment

Spare parts kit	Part no.	104355B
-----------------	----------	---------

Motor size 52		Flange motor				Bracket motor			
		without gearing	with planetary gear			without gearing	with planetary gear		
Motor, reversible by integrated hand lever	Type Part no.	FM52SU 441741A	FM52LU 441831A	FM52LLUA 442105A	FM52LLUB 442106A	KM52SU 441876A	KM52LU 441877A	KM52LLUA 441878A	KM52LLUB 441879A
Nominal power	kW / HP	4.6 / 6.2	4.5 / 6.0	4.5 / 6.0	4.5 / 6.0	4.6 / 6.2	4.5 / 6.0	4.5 / 6.0	4.5 / 6.0
Nominal speed	rpm	2800	240	100	75	2800	240	100	75
Speed (idling)	rpm	5600	480	200	150	5600	480	200	150
Nominal torque	Nm / in.lbs	16 / 142	180 / 1593	430 / 3805	573 / 5071	16 / 142	180 / 1593	430 / 3805	573 / 5071
Start torque min.	Nm / in.lbs	24 / 212	270 / 2389	645 / 5708	860 / 7611	24 / 212	270 / 2389	645 / 5708	860 / 7611
Air consumption	m ³ /min / cfm	5 / 176	5 / 176	5 / 176	5 / 176	5 / 176	5 / 176	5 / 176	5 / 176
Weight	kg / lbs	29.3/64.46	28.2/62.04	35.9/79	36.3/79.86	33.7/74.14	35.4/77.88	44.8/98.56	45.2/99.44
Hose I.D., supply air/exhaust air	mm / in.	25 ⁶³ / ₆₄ / 32 ¹¹⁷ / ₆₄				25 ⁶³ / ₆₄ / 32 ¹¹⁷ / ₆₄			

Performance data relate to an air pressure of 6 bar (85 PSI) and lubricated air

Optional equipment

Spare parts kit	Part no.	104355C
-----------------	----------	---------

 **Maintenance unit**
on page 41

 **Model number description**
on page 46

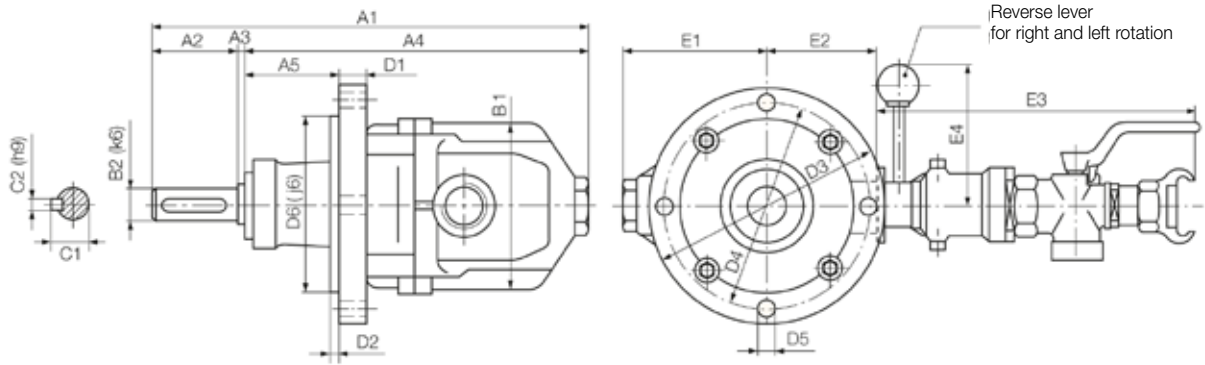



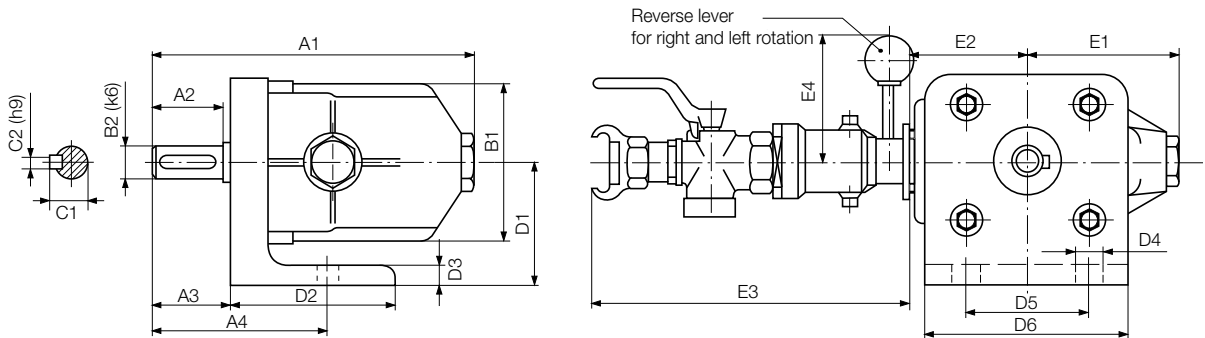



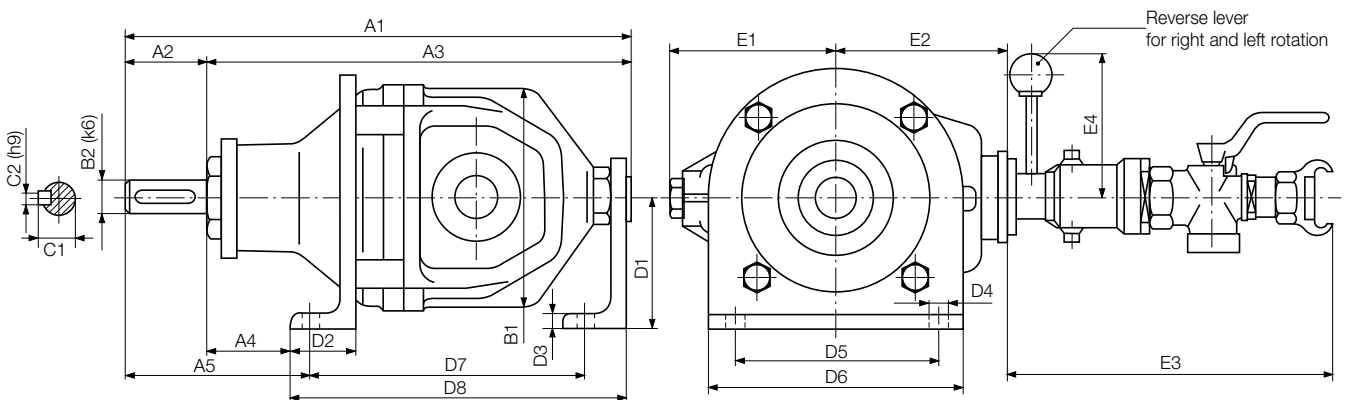



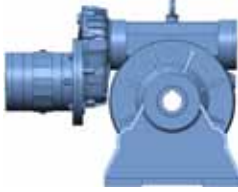





Motor size	Type	Dimensions flange motor (mm)																			
		A1	A2	A3	A4	A5	B1	B2	C1	C2	D1	D2	D3	D4	D5	D6	E1	E2	E3	E4	
32	FM32SU	195		3	144	-						4									
	FM32LU	283	50	2	231	63	132	25	27.9				190	160		138	107	117.5			
	FM32LLUA/B	364		2	313	102		30	32.9	8											
50	FM50SU	243		2	182	5					22										
	FM50LU	364		-	304	97		35	38.3	10		5			14				273	140.5	
	FM50LLUA/B	435	60	-	374	113	162	40	43.1	12			220	195		165	105	130			
52	FM52SU	262		2	202	5		30	32.9	8											
	FM52LU	384		-	324	95		35	38.3	10											
	FM52LLUA/B	454		-	394	112		40	43.1	12											



Motor size	Type	Dimensions bracket motor (mm)																		
		A1	A2	A3	A4	B1	B2	C1	C2	D1	D2	D3	D4	D5	D6	E1	E2	E3	E4	
32	KM32SU	195	50	54	119	132	25	27.9												
50	KM50SU	242							8	105	115		13	90	150	107	117.5			
52	KM52SU	262	60	62	142	162	30	32.9		120	130	14	14	116	182	105	130	273	140.5	

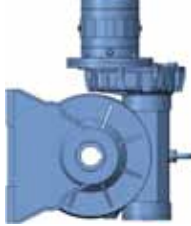

Motor size	Type	Dimensions bracket motor (mm)																				
		A1	A2	A3	A4	A5	B1	B2	C1	C2	D1	D2	D3	D4	D5	D6	D7	D8	E1	E2	E3	E4
32	KM32LU	303	50	253	40	90	132	25	27.9	8	93				120	160	161	211	107	117.5		
	KM32LLUA/B	384		334	76	142.5		30	32.9		50				205	255	204	254	105			
	KM50LU	384		324	69	143.5		35	38.3	10					150	190	204	254	105			
50	KM50LLUA/B	454	60	394	30	121	162	40	44.1	12	100	45	14	13	120	160	265	360	112		273	140.5
	KM52LU	403		343	68	143		35	38.3	10		50			150	190	223	273	105	130		
	KM52LLUA/B	474		414	31	121		40	43.1	12		45			120	160	285	380	115			

Bracket motor	Flange motor Flange layout F_1 / F_2	Universal mounting
OB3 	OB3 	OB3 
OB6 	OB6 	OB6 
OB7 	OB7 	OB7 
OB8 	OB8 	OB8 
OV5 	OV5 	OV5 
OV6 	OV6 	OV6 

Bracket motor

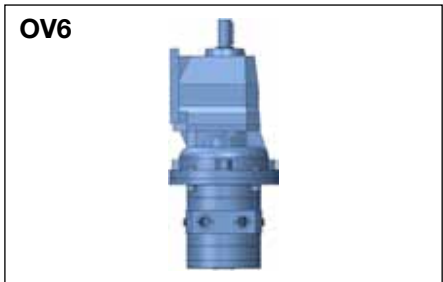
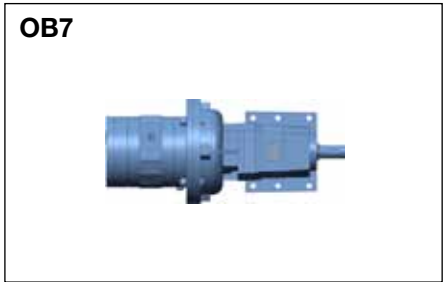
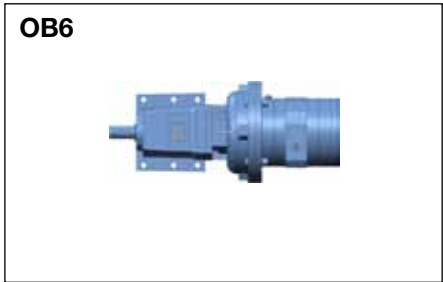
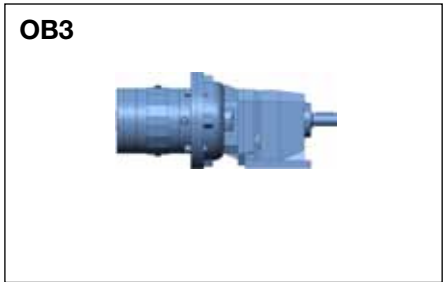

Flange motor

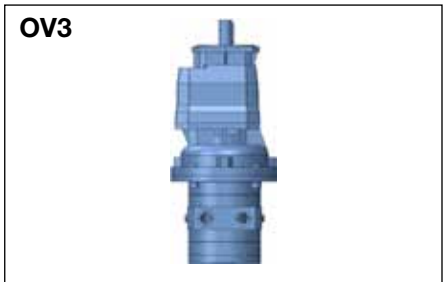
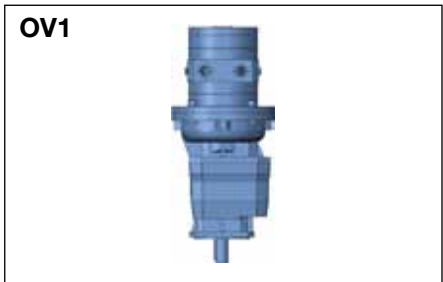

Holding brake

Our holding brakes are designed for the motors 68X-...F09, 68X-...F11, 68X-...F13 and 68X-...F15 and can be ordered fully mounted together with the motors.

In addition the holding brake is also suitable for upgrading.

We can carry out this upgrade for you on request.

Appropriate for each motor	Type	68X-...F09	68X-...F11	68X-...F13/...F15
Holding brake	Part no.	445709B	446196B	446062C

*) The holding brake is not designed for use with a different drive system. Please only use it in combination with the stated motor types.

The braking torque is generally double the nominal torque.

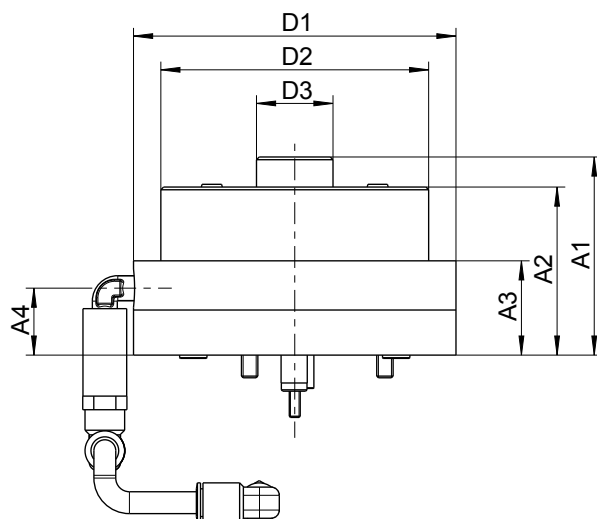
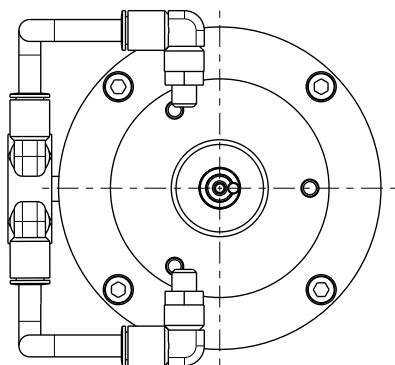

p440244

Type	Dimensions of braking device (mm)						
	A1	A2	A3	A4	D1	D2	D3
M9U	72.5	61.5	34.5	24.5	118	98	28
M11U							
M13U	83	-	39	30	190	162	-
M15U							

Drive spindle options for motors with worm gears

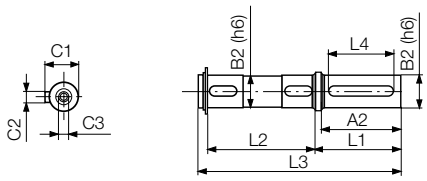

Spindle for motors with worm gears

Part no.	for hollow shaft mm	Radial force max. N / lbs.	Axial force max. N	Dimensions (mm)									
				A2	B2	C1	C2	C3	L1	L2	L3	L4	
824328	Ø25 x 82	3450/770	690/150	60	25	28	8	M8	65	82	154	50	W49
824329	Ø25 x 120	5000/1120	1000/224							120	192		W63
107573	Ø30 x 127	6200/1389	1240/278		30	33	8			M10	127		199
824330	Ø35 x 140	7000/1560	1400/310	75	35	38	10	M12	80	140	214	60	W86
824331	Ø42 x 155	8000/1790	1600/355							42	45		12
824332	Ø45 x 165	13800/3090	2760/615		45	48.5	14			85	165		261

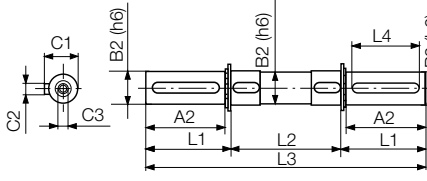

Spindle for motors with worm gears

Part no.	for hollow shaft mm	Radial force max. N / lbs.	Axial force max. N	Dimensions (mm)									
				A2	B2	C1	C2	C3	L1	L2	L3	L4	
824333	Ø25 x 82	3450/770	690/150	60	25	28	8	M8	63.2	82	208.4	50	W49
824334	Ø25 x 120	5000/1120	1000/224							120	246.4		W63
813122	Ø30 x 127	6200/1389	1240/278		30	33	8			M10	64		127
824335	Ø35 x 140	7000/1560	1400/310	75	35	38	10	M12	79.2	140	268	60	W86
824336	Ø42 x 155	8000/1790	1600/355							42	45		12
824337	Ø45 x 165	13800/3090	2760/615		45	48.5	14			84.7	165		334.4

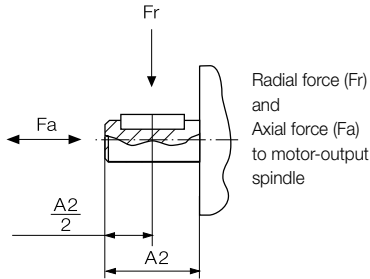

Flange design for motors with worm gears

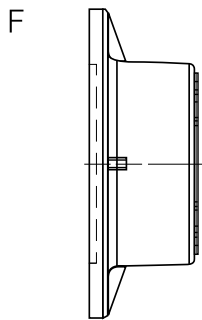

Flange for motors with worm gears

Type of gearing	Part no.
W63U	830929
W75U	834335
W86U	830931
W110U	830934

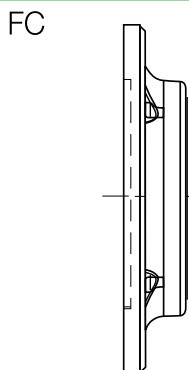

Flange for motors with worm gears

Type of gearing	Part no.
W63U	830930
W75U	106042
W86U	830932
W110U	830935

ACCESSORIES

Set of Silencers (including mounting set according below table)

Suitable for	Motor size	9	11	13	15	55	65
Hose set (supply air/exhaust air hose), length 2 m							
motor is reversible (right and left rotation)	Part no.	310740A	310741A	310742A	310742A	-	-
motor operates in one direction (right or left rotation)	Part no.	310740D	310741D	310742D	310742D	-	-
Noise level	dB(A)	124.7	122.8	119.2	122.1	123	-
Exhaust filter including air supply/exhaust hose							
motor operates in one direction (right or left rotation)	Part no.	310740B	310741B	-	-	-	-
Noise level	dB(A)	88.1	90	-	-	-	-
Silencer including air supply/exhaust hose							
motor operates in one direction (right or left rotation)	Part no.	310740C	310741C	310742C	310742C	-	-
Noise level	dB(A)	89.9	93.8	90.5	91.9	-	-
Set of Silencers (including mounting set according below table)							
motor operates in one direction (right or left rotation)	Part no.	-	-	-	-	440615C	440614A
motor is reversible (right and left rotation)	Part no.	-	-	-	-	440615B	440614B
Noise level	dB(A)	-	-	-	-	106	120

Part no.	Contained	A (Supply air)		B (Exhaust air)		C/D/E/F	
		D1	D2	D1	D2	D3	D4
310740A	A, B	19				-	-
310740B	A, B, C					110	285
310740C	A, B, D	15	G $\frac{1}{2}$	19	G $\frac{1}{2}$	100	195
310740D	A, B					-	-
310741A	A, B	25				-	-
310741B	A, B, C					110	285
310741C	A, B, D	19	G $\frac{3}{4}$	25	G $\frac{3}{4}$	100	195
310741D	A, B					-	-
310742A	A, B	32				-	-
310742C	A, B, E		G1	32	G1	134	434
310742D	A, B	25				-	-
440615C	3xE	25	G1	32	G1		
440615B	2xE					134	434
440614B	F	43	G2	-	G 2 $\frac{1}{2}$		
440614A	E, F				G2; G 2 $\frac{1}{2}$		

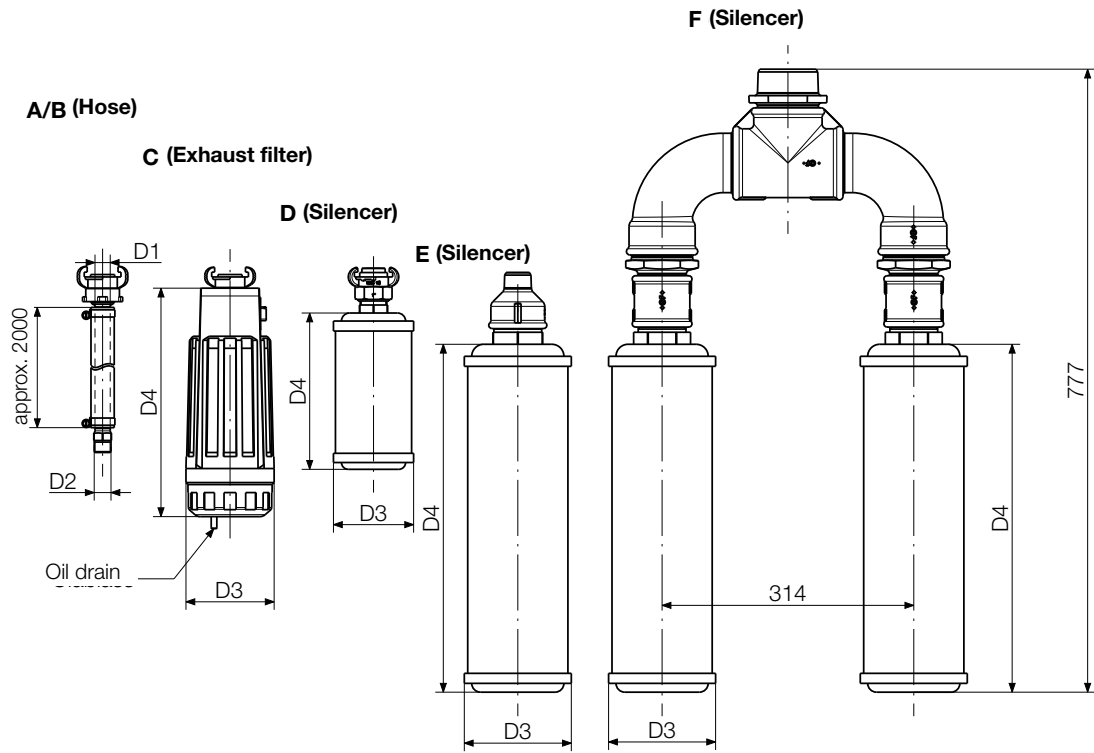

Dimensions in mm

p107521

ACCESSORIES

Maintenance unit consisting of filter, oiler and double nipple - alternatively available with or without pressure regulator
Pressure regulation valve with manometer

Suitable for Motor size (MG) Type of motor	Part no. Maintenance unit with- out pressure regulator	Part no. Maintenance unit with pressure regulator	Part no. Pressure regulation valve with manometer	Thread size	Regulation range
MG9 ----- MG11 ----- FM32/KM32 ----- FM50/KM50 ----- MG13/15 ----- FM52/KM52 ----- 68X-001F55/IEC112A ----- 68X-001F65/IEC112A	821609A	821179A	821999A	G1	0.5 - 10 bar
	805044A	805044B	816657A	G 1 ½	
	350005A	350005B	816658A	G2	

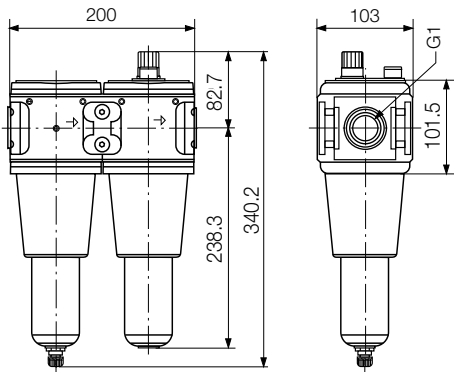

821609 A
Maintenance Unit without pressure regulator G1

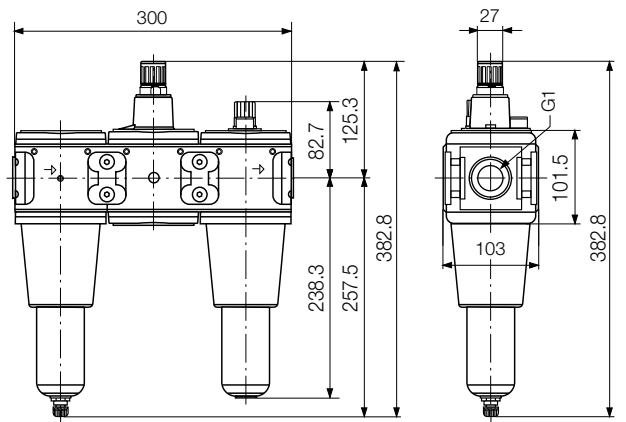

821179 A
Maintenance Unit with pressure regulator G1

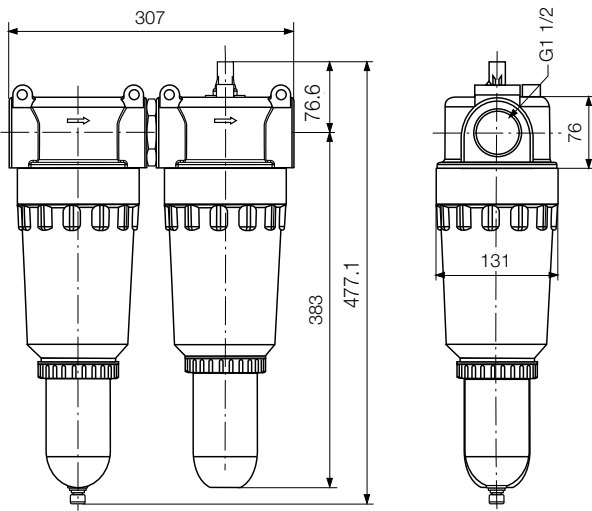

805044 A
Maintenance Unit without pressure regulator G1 1/2

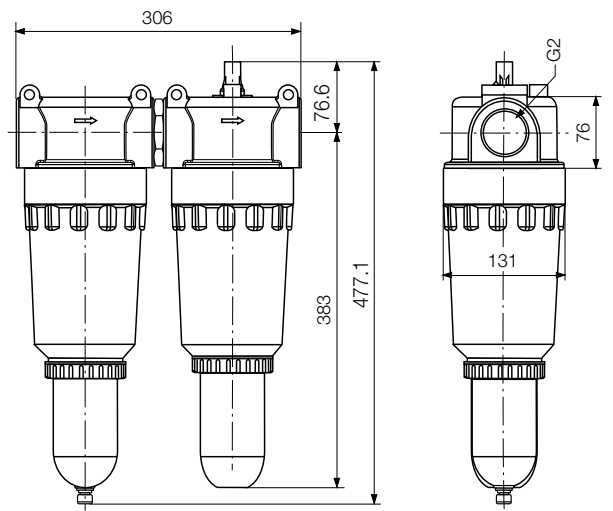

350005 A
Maintenance Unit without pressure regulator G2

MODEL NUMBER DESCRIPTION - when ordering please indicate model designation

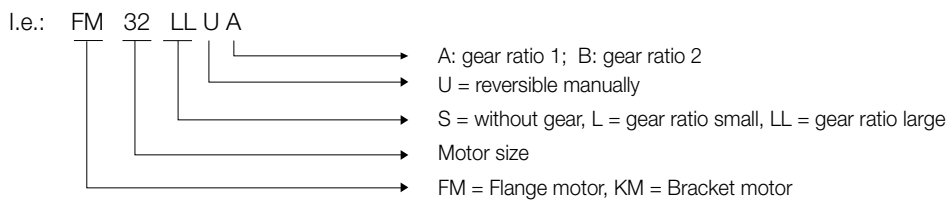
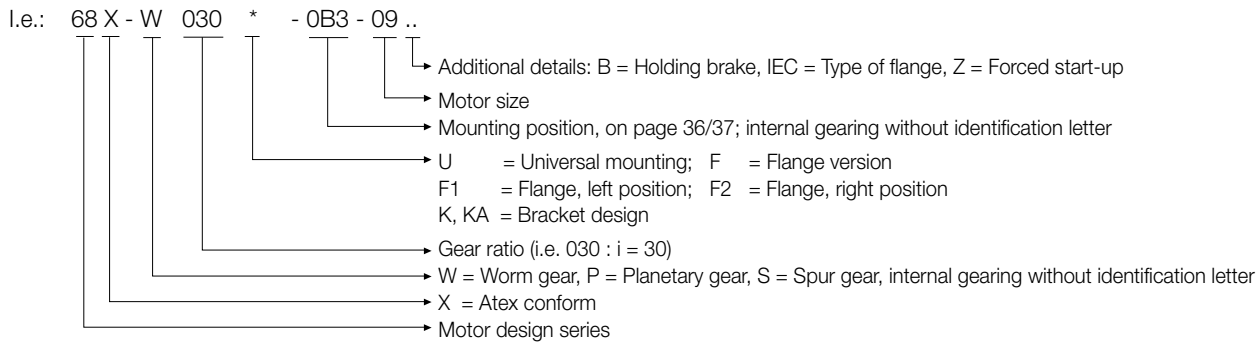

Use in potentially explosive environments



The correspondingly marked motors are suitable for use in potentially explosive environments.

Do you need support in selecting the right drive system?

Tell us your operational conditions and our application consultants will be happy to help:

Application:	<input type="text"/>		
In what kind of environment will the motor be installed?	ATEX requirement / explosion safety?	<input type="checkbox"/> yes	<input type="checkbox"/> no
	if yes, which safety class:	<input type="text"/>	
	food industry conformity?	<input type="checkbox"/> yes	<input type="checkbox"/> no
	sterilisable?	<input type="checkbox"/> yes	<input type="checkbox"/> no
	acid resistant?	<input type="checkbox"/> yes	<input type="checkbox"/> no
	steam resistant?	<input type="checkbox"/> yes	<input type="checkbox"/> no
Application conditions:	constant operation (24 hrs, non-stop)	<input type="checkbox"/> yes	<input type="checkbox"/> no
	duty cycle in hrs/day:	<input type="text"/>	
	days/year:	<input type="text"/>	
	cycle time (s):	<input type="text"/>	
	motor loaded to stall?	<input type="checkbox"/> yes	<input type="checkbox"/> no
	self-locking?	<input type="checkbox"/> yes	<input type="checkbox"/> no
Required turn direction:	<input type="checkbox"/> left	<input type="checkbox"/> right	<input type="checkbox"/> reversible
	(view from air inlet)		
Motor performance:	power:	<input type="text"/>	W
	nominal torque:	<input type="text"/>	Nm
	nominal speed:	<input type="text"/>	rpm
Performance influencing application conditions:	operating pressure (at motor inlet):	<input type="text"/>	bar
	operation with lubricated air possible?	<input type="checkbox"/> yes	<input type="checkbox"/> no
	smallest opening cross-section of connection pieces and hoses?	<input type="text"/>	mm
External motor design:	<input type="checkbox"/> standard steel	<input type="checkbox"/> non-corrosive	<input type="checkbox"/> aluminium
	<input type="checkbox"/> plastics	<input type="checkbox"/> ceramics	
	other:	<input type="text"/>	
Drive spindle design:	drive shaft requirements:	<input type="text"/>	
	(e. g. keyed shafts, square end, hexagonal, collet, drill chuck taper, etc.)		
	required dimensions:	<input type="text"/>	
Motor fixture design:	mounting requirements: (bracket, flange, etc.)	<input type="text"/>	
	required dimensions:	<input type="text"/>	
Additional components:	<input type="checkbox"/> holding brake	<input type="checkbox"/> operational brake	
	gear box:	<input type="text"/>	
Price range:	<input type="text"/>		
Annual requirement:	<input type="text"/>		

DEPRAG

DEPRAG SCHULZ GMBH u. CO.

P.O. Box 1352, D-92203 Amberg, Germany
Carl-Schulz-Platz 1, D-92224 Amberg
Phone (+49) 9621 371-0, Fax (+49) 9621 371-120
www.deprag.com
info@deprag.de

CERTIFIED AS PER DIN EN ISO 9001
