

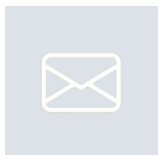

## Air Motors

### Customized drive solutions



- compact
- service friendly
- stainless steel
- light
- ATEX conform
- robust
- overload safe
- reversible
- sterilisable

# OVERVIEW

---

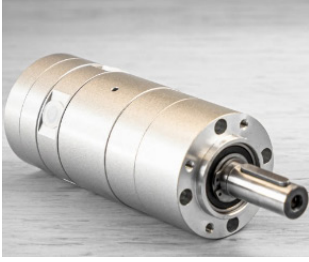

**Fields of application and application examples for Air Motors**

**Pages 3 - 5**

**What distinguishes DEPRAG Air Motors from the rest?**

**Pages 6 - 7**

**Advantages of Air Motors**

**Page 8**

**Our Product spectrum**

**Pages 9 - 13**

- **Product spectrum: Tooth Gear Motors**
- **Product spectrum: Turbines**
- **Product spectrum: Air Vane Motors**
  - BASIC LINE: Low cost air motors for normal production environment
  - ADVANCED LINE: Stainless steel motors
  - POWER LINE: High performance air motors
  - INDIVIDUAL LINE: Great value customisations
  - Air Vane Motors for special applications
    - Drilling, milling and grinding motors
    - Air motors with integrated holding brake
    - Gear motors

**Speed regulator**

**Page 13**

**Technical Information about Air Vane Motors**

**Pages 14 - 17**

- Function of the air vane motor
- Air quality and oil-free operation
- Explosion prevention
- Comparison of drive principles
- Characteristic curve of the air vane motor

**Selecting your Air Motor for your application**

**Pages 18 - 25**

**Infinite variable regulation of the air pressure or air volume**

**Page 26**

**Installing your Air Vane Motor**

**Page 27**

## Fields of application for air motors

Diverse design models, simple construction, light performance weight, high speed ranges and explosion safety – this ensures that air motors can be used in a wide spectrum of applications.

DEPRAG air motors – whether vane motors, turbine motors or tooth-gear motors – are employed in almost all sectors of industry.



### Medical technology pharmaceutical industry

- sterilisable
- light – small
- high performance
- reliable
- long life-span
- oil-free operable
- easy maintenance



### Food processing industry

- food industry conform
- sealed
- resistant to cleaning agents
- oil-free operable
- highest reliability



### Ship building, underwater usage

- ATEX conform
- high performance
- robust
- easy maintenance

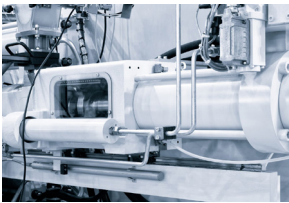

### Paper industry

- stainless steel design
- high performance
- reliable
- long life-span
- easy maintenance



### Foundries, iron works and power plants

- ATEX conform
- high performance
- long life-span
- easy maintenance
- robust

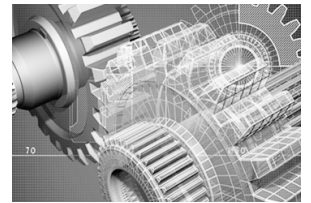

### Machine construction

- non-corrosive
- insensitive to vibrations
- ATEX conform
- robust
- easy maintenance



### Automobile industry

- ATEX conform
- high performance
- long life-span
- easy maintenance
- robust



### Chemical industry

- ATEX conform
- resistant to cleaning agents
- insensitive to acids
- high performance
- long life-span
- easy maintenance



### Air tools

- ergonomic
- robust
- easy maintenance
- long life-span
- high performance
- oil-free operable

**Agitator motors,  
transport and materials handling  
technology and much more...**

**We have the right custom made drive solution for your individual application  
... no matter whether air vane motor, tooth-gear motor or turbine  
... irrespective of your required material, we will provide you with  
the best value for money customisation.**



## Application examples air vane motors



### High performance in the smallest of spaces...

is achieved by the resilient air motor which drives the milling head of a sanitation robot under the extreme conditions of drain sanitation.

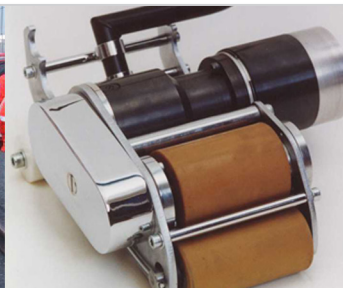

### Move a parked aircraft by hand!

Moving heavy rolls of paper, railway wagons, and even parked aircrafts by hand may sound like magic, but it is humanly possible: The unassuming "Easy Roller" works just as its name implies. With this device, you can easily maneuver up to 100 tons without exerting great effort.



### Drive solution for the paper production

Acid- and heat-insensitive stainless-steel motors for difficult requirements.



### Drive Technology for the Fruit-Juice Production Industry

For the stirring and mixing of fruit juices, we offer a robust and reliable ADVANCED LINE air-motor made from stainless steel with a power output of 300 watts. This motor drives the propeller of a magnetic agitator.

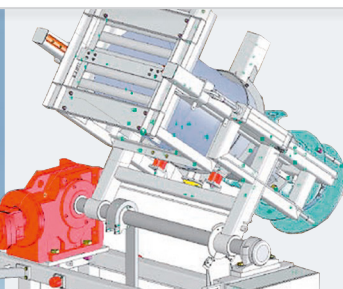

### ATEX conform complete system:

#### Air motor - brake - gear

Wilfried Beer, managing partner of Beer Fördertechnik:

"By using this complete system for my vat drainage equipment I can save myself enormous additional construction and manufacturing expenses because the brakes which provide the safety for my mechanism are already integrated."



## Application examples of turbines and gear motors

### The different application areas of the turbine

The DEPRAG gas expansion turbine recovers energy, meaning that even small amounts of residual process gas can be utilised. This means that energy recovery with the latest technology is an option for many sectors of industry.



**Energy recovery in energy-intensive industrial processes**



**Energy recovery from residual energy in power stations**



**Energy recovery through gas expansion in the natural gas network**

### Using a turbine for an aircraft emergency door

The pyrotechnic ignited, indirect turbine drive with reduction gearing is used for the PYROTAK emergency door system. This system offers a high power-output by a very small-sized turbine.

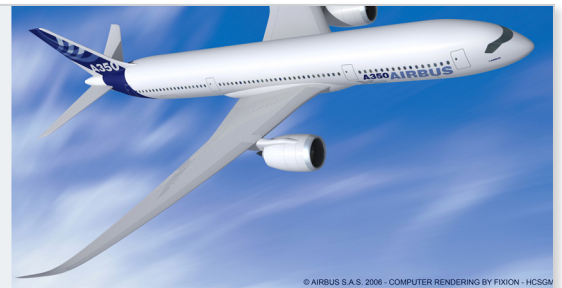

### Example: Turbine grinding machine

A two-stage Curtis-turbine is used for this turbine grinder.

When compared to multi-stage overpressure turbines, this grinder has a simple layout and is especially cost effective.

The deciding advantage for this application is the extreme low weight.



### Application: Turbine grinder

Use of a high-speed turbine in a turbine grinder.



### Application example of gear-motors

An application example is the use of gear-motors in high-speed midget grinders for the deburring of molds and dies and for the fabrication of non-metallic materials with high cutting speed.



## What distinguishes DEPRAG Air Motors from the rest?

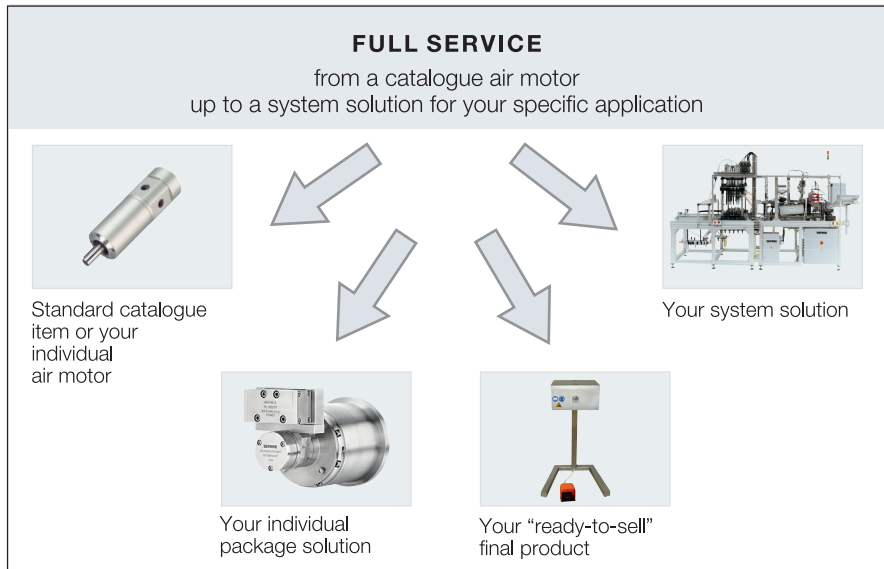

### FULL SERVICE

Whether you need an integrated motor from our comprehensive programme catalogue, your own individual air motor, a package solution, a ready-to-sell end product or a fully automated assembly system – DEPRAG is your business partner.

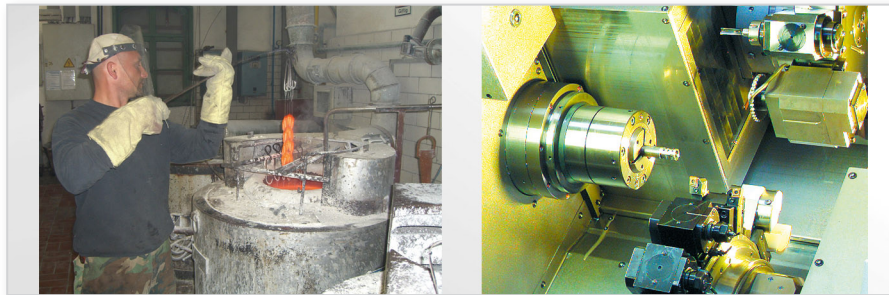

Large amount of in-house production – on-site salt bath heat treatment facility

### SHORT DELIVERY TIMES

Due to our large amount of in-house production we are able to deliver fast and flexibly at short notice, even when dealing with smaller quantities.

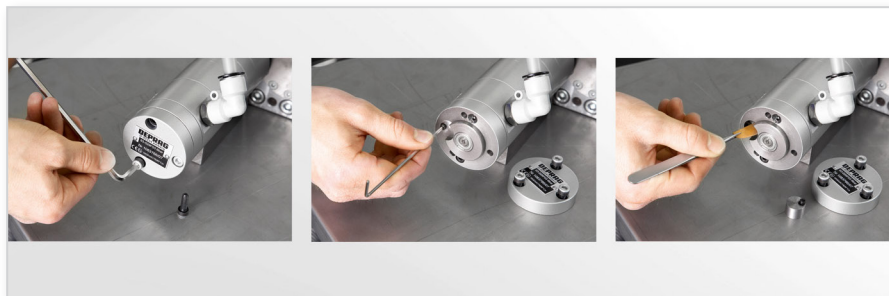

QuickVChange vane exchange system

### EASY MAINTENANCE

We offer a QuickVChange vane exchange system for our BASIC LINE product line. There is no need to dismantle the air motor during vane exchange, thus saving valuable production time!



Air motor-gear-valve, a system for the paper industry made of stainless steel; sealed stainless steel motors and high performance vanes

### LONG LIFE-SPAN

A wide product range of stainless steel motors, the use of DEPRAG high performance vanes as well as a specific surface coating on our materials, all this ensures your motor's long life-span.



## What distinguishes DEPRAG Air Motors from the rest?

### FLEXIBILITY

As well as wide-ranging ADVANCED LINE and BASIC LINE standard programmes, we offer flexible choice of materials, e.g. ceramic, or designs tailored to meet your needs.



Innovative materials, e.g. ceramic motor; customer specific package solutions

### APPLICATION CONSULTANCY

Our application engineers advise you in selecting the most suitable drive system for your application. If you would like to test or replace your existing drive, we are happy to check it in our innovative performance testing facility.



Performance testing facility; professional guidance from our engineers

### SERVICE AND MAINTENANCE

We will gladly carry out regular maintenance on your air motor. Ask about our maintenance offer. Appropriate service and maintenance kits for our air motors are also available.



Worldwide service

### GREAT VALUE CUSTOMISATION

Our standard programme features a high variety of different designs. Planetary gears, spur gears or worm gears are optionally available for all our air motors. On the basis of our modular principle we also provide individually customised products at an attractive price/performance ratio.



Individually customised products at an attractive price



## Advantages of Air Motors

---

Air motors are safe and robust drive systems, which come into play when a high performance and overload safe drive is required. Always ready for action long after traditional drive technology has stopped spinning!



**safe**  
for use in potentially  
explosive environments



**sealed**  
even for underwater usage



**insensitive to acids**



**sterilisable**  
for repeated use in  
clean-rooms



**resistant to cleaning agents**  
and suitable for the high  
standards of the food  
processing industry

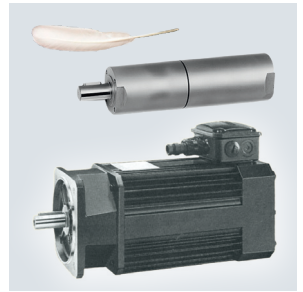

**light and compact**  
only  $\frac{1}{5}$  of the weight and  $\frac{1}{3}$   
of the size of an electric  
motor of equivalent power



**insensitive to vibrations**



**insensitive to heat**

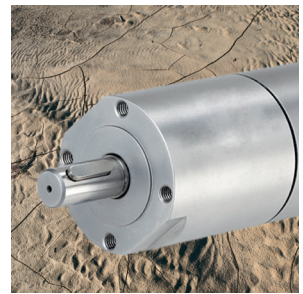

**insensitive to dust**



**overload safe**  
can be loaded to standstill  
with no damages

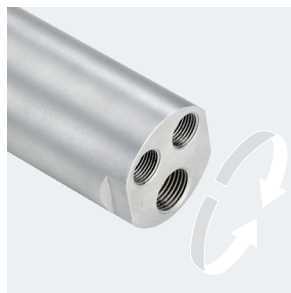

**reversible**  
can be set in both  
rotational directions



**easy to control**  
smoothly controlled by  
altering the pressure or  
air quantity (throttling)

# Our Product spectrum

## Our product lines:

## Advantages:

## Product spectrum:

### Tooth-Gear Motors

- speeds up to approx. 100,000 rpm
- oil-free
- no wear parts
- low noise level
- suitable for continuous use

Tooth-gear motors are developed individually to fit your requirements.

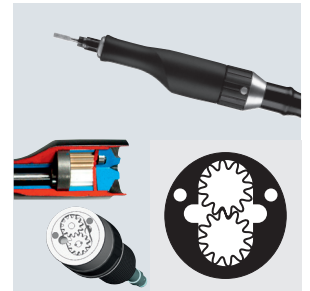

### Turbines

- speeds up to approx. 120,000 rpm
- oil-free
- no wear parts
- optimum power to weight ratio
- low air consumption

- Turbines with flexible power settings 1.5 kW / 3 kW or 4.5 kW
- Turbine production according to your specific application.

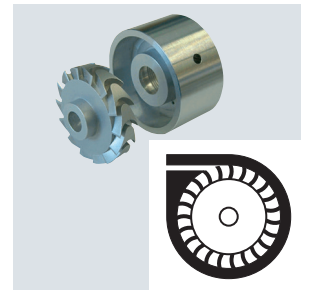

### Air Vane Motors

- speeds up to approx. 60,000 rpm
- compact & light
- ATEX conform
- overload safe
- robust & powerful

- BASIC LINE
- ADVANCED LINE
- POWER LINE
- INDIVIDUAL LINE
- Grinding, milling & drill motors
- Air motors with integrated holding brake
- Gear motors

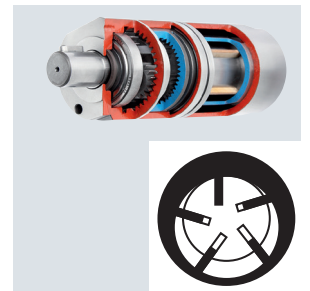

### Speed regulator

- universally applicable due to the unlimited parameter setting
- large range for speeds up to 80,000 rpm
- high resolutions and highly accurate control

A speed regulator is well-suited for applications such as an agitator or mixer, where a constant speed is a prerequisite for an accurate production.



## Product spectrum: Tooth-Gear Motors

Our tooth-gear motors provide made-to-measure drive solutions for your individual application needs.

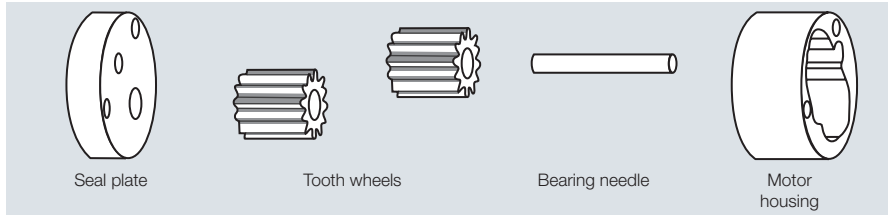
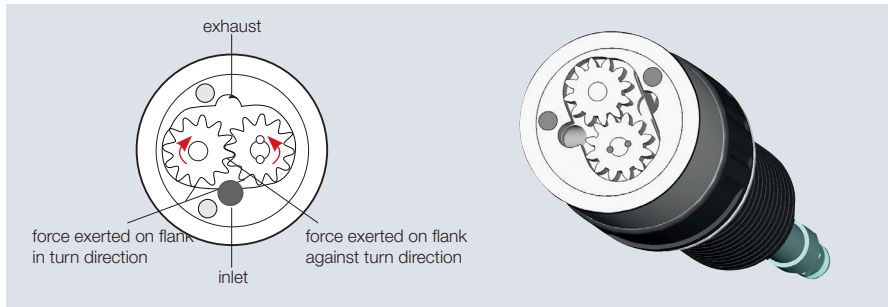

Gear motors are operated oilfree.

### Function of a Gear Motor

Gear motors consist of two gear wheels, that run in a housing with minimal play. One gear-wheel is rigidly interconnected with the drift shaft, the other generates the torque. Two gear-flats are directed with compressed air into the turn-direction and one gear-flat against the turn-direction. The exhaust air is directed into chambers - that are formed between the gear-flat and housing wall - towards the exhaust air side and rotation is generated.

### Design of a Gear Motor



## Product spectrum: Turbines

### DEPRAG turbine technology – one drive, 3 power levels

Our powerful turbines promise high torques in every application. Even under load, the integrated speed controller ensures a constant speed. Our compact turbine drives are the perfect choice for various applications. For example, they are suitable as air starters for small and medium-sized combustion engines and gas turbines. They also provide a powerful drive in drilling machines, grinding and milling tools.

With our turbines, we offer energy-efficient, high-speed drives that are suitable for continuous operation and guarantee low air consumption with an optimum power-to-weight ratio.

The highlight: the output of our turbine motors can be flexibly adjusted to 1.5 kW, 3.0 kW or 4.5 kW. Our drives are available with speeds of 80 - 3,400 revolutions per minute.

### Advantages of our turbine motors

Thanks to the adjustable output (1.5kW/3kW/4.5kW), our turbines offer maximum flexibility and achieve nominal speeds of 70 - 2880 rpm.

- Oil-free operation
- Optimum power-to-weight ratio
- Low air consumption
- No wearing parts
- ATEX compliant
- Right rotation or left rotation
- Flexible installation position

With our turbines, we offer energy efficient, high speed drives that are suitable for continuous operation and guarantee low air consumption with an optimum power to weight ratio. The turbine is fluid mechanically designed and calculated, constructed and customised for your specific application. The following individual parameters are taken into account:

- Mass flow or desired power output
- Inlet/outlet pressure
- Medium (type of gas)
- Speed, turn-direction
- Inlet temperature
- Mounting preference
- Material request

### Design and functionality of a turbine motor

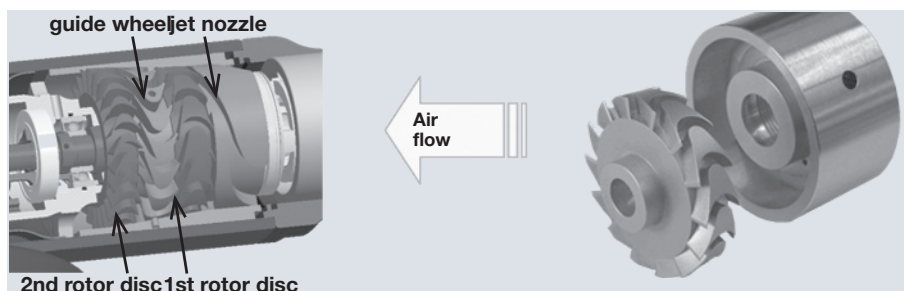

The turbine does not require any contact seals. Therefore, the operation of the turbine with non-lubricated compressed-air is totally free from wear. Continuous-flow machines optimally utilize the energy of

compressed air. Therefore, the air requirement of a turbine motor is 1/3rd less when compared to a non-pneumatic vane motor. The power to weight ratio [kg/kW] is only half.

Pneumatic turbines are continuous-flow machines, which can be executed in single-stage or dual-stage design.

The conversion of the pressure energy into kinetic energy takes place in the inlet nozzle. On a two-stage turbine, the largest part of the kinetic energy is converted in the 1st turbine wheel. The air-flow is diverted over the stationary turbine wheel. The remaining energy is converted in the 2nd turbine wheel.



## Product spectrum: Air Vane Motors

With our standard, cataloged air vane motors, we can offer completely adapted drive solutions for your application.

### BASIC LINE

Our great value for money model for use in non-critical production environments. Additional benefit: You save production time with our QuickVChange vane exchange system!

**Power range:**

200 - 1200 W

**Your advantages:**

- ATEX certified
- QuickVChange vane exchange system
- wide speed range
- reversible
- robust design

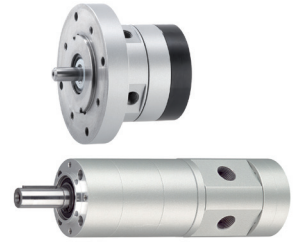

### ADVANCED LINE

Our product line of stainless steel motors stands out from the rest with its comprehensive range of sealed, oil-free operable, non-corrosive air motors. Particularly suitable for use in the paper industry, food processing industry, for medical technology and much more...

**Power range:**

20 - 1200 W

**Your advantages:**

- ATEX certified
- non-corrosive
- oil-free operable
- sealed
- reversible
- with integrated holding brake
- high performance, small size



### POWER LINE

Our product line of high performance bracket and flange motors also features wide versatility. The high starting torque with an unparalleled low performance weight, the robust and reliable design are all clear advantages in comparison with an electric drive.

**Power range:**

1.6 - 18 kW

**Your advantages:**

- high performance
- high starting torque
- low performance weight
- robust, reliable design
- long life-span

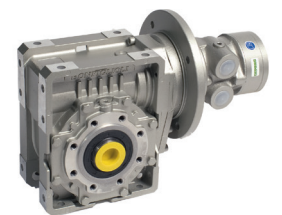

### INDIVIDUAL LINE

The cost efficient and customized air-motor can be derived from our modular construction system, be based on a customer-specific product or on a totally customized solution.

**Your advantage:**

- attractive price-performance ratio



## Air Vane Motors for special applications

### Drilling, milling and grinding motors



#### Drill Motors

Our efficient drill motors with slim design allow the smallest of drill spacings when using multi-spindle units, such as for the construction of windows.

**Power range:**

80 - 600 W

**Speed range:**

150 - 24,000 rpm

**Your advantages:**

- high precision drill chuck with taper fitting



#### Milling Motors

The durable milling motors with a superior run-out precision, are the first choice for robotic applications, since they are small in size but powerful at high speeds.

**Power range:**

400 W

**Speed range:**

max. 20,000 rpm

**Your advantages:**

- robust and precise bearing
- high running precision



#### Grinding Motors

The DEPRAG grinding motor program benefits from decades of experience with the tried and tested DEPRAG handheld pneumatic grinders. The robust steel housing guarantees high accuracy and operational reliability. Furthermore, the grinders feature extremely precise collets for various shaft diameters and offer a high run-out accuracy.

**Power range:**

150 - 1000 W

**Speed range:**

15,300 - 47,000 rpm

**Your advantages:**

- high precision collet for various shaft diameters
- high running accuracy

### Air motors with integrated holding brake

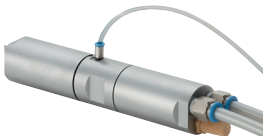

A cost effective total solution:

Benefit by using our standard program of air-motors that feature an integrated brake-module.

The integrated brake equipment can be controlled either via a separate control line or directly via the airmotor exhaust. If pressure drops in the line the brake is automatically activated.

DEPRAG air motors with integrated holding brake are suitable for use in any application area due to their optimal size and design in which safety plays an important role.

The DEPRAG ADVANCED LINE stainless steel motors and the 1.6 kW, 3.2 kW, 5.0 kW and 6.0 kW POWER LINE are available with integrated holding brake.



konformes System: Druckluftmotor-Bremse-Getriebe

#### NEW:

The world's first ATEX conform complete system, consisting of

#### air motor, holding brake and planetary gear

can be found as a standard product in the ADVANCED LINE air motor program for 20 W - 1.6 kW stainless steel airmotors.

The brake is controlled via a separate control line ( $p > 5$  bar) with integrated safety valve.

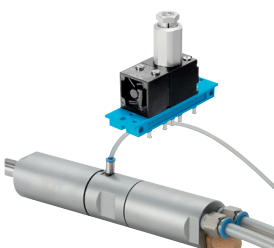

# Air Vane Motors for special applications

## Gear Motors

Due to high speeds, gears which are suited to a particular torque / speed are often required.

The DEPRAG product spectrum consists of numerous gear motors with precision planetary gears for high torque for very small sizes, spur gears or worm gears to transfer high torque at low speeds.

### Advantage Planetary Gear:

- compact design
- high degree of re-usability
- any installation position
- gear ratio  $i = 5-308$

### Advantage Spur Gear:

- cost-effective
- any ratio:  $i = 7-238$

### Advantage Worm Gear:

- cost-effective
- compact design
- high gear ratio of 14-80 available in one step
- self-retention

### Planetary Gears



### Spur Gears

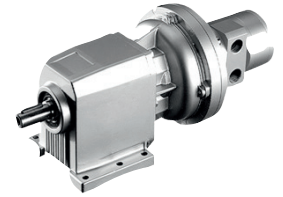

### Worm Gears

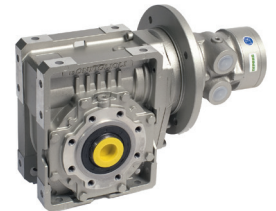

## Speed regulator – Innovative system solution to equalize speed-fluctuations

A speed regulator is well-suited for applications such as an agitator or mixer, where a constant speed is a prerequisite for an accurate production.

The DEPRAG speed regulator consists of a non-contacting speed sensor that is directly integrated into the air-motor between the actual vane-motor and the gearing.

The sensor acquires the current speed and transfers the digital signal to the regulator.

If there is a variation, a special valve is actuated, which regulates the airflow for the motor.

The control module is integrated into a DIN-rail-housing, which allows the installation into a customer's control box. The operator friendly LC-display is used for the simple and uncomplicated selection of the required speed value.

### Your advantages: Universally applicable due to the unlimited parameter setting

This new speed regulator can be used with different applications. Some processes

focus more on the regulator speed while other processes require a high accuracy of the regulator. DEPRAG speed regulator can be individually programmed for either application and is therefore universally applicable.

### Large range - speeds up to 80,000 rpm

The complete product range of our air-motors can be served by this speed regulator.

### High resolutions and highly accurate control

Even an air-motor with a very low speed can be reliably regulated. The speed is evaluated from a full rotation to a 1/32 of a rotation and regulated to correspond with the nominal value. Even air motors with a high speed are easily controlled by the proportional regulator-valve because of the regulator's high resolution and accuracy. The output signal for the control of the valve is 0-10V, the resolution of the regulator voltage is therefore 2.5 mV.





## Function of the DEPRAG Air Vane Motors

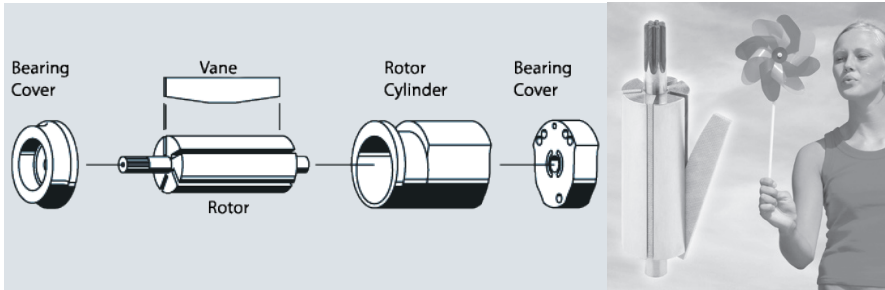

All vane motors essentially consist of the rotor, which circulates in an eccentrically offset perforation of the rotor cylinder. Because of this eccentrically offset perforation, the vanes form working-chambers, the volume of which increases in the turn direction. Because the expansion of the compressed supply air, the pressure energy is converted into kinetic energy, and therefore, results into the rotation of the rotor.

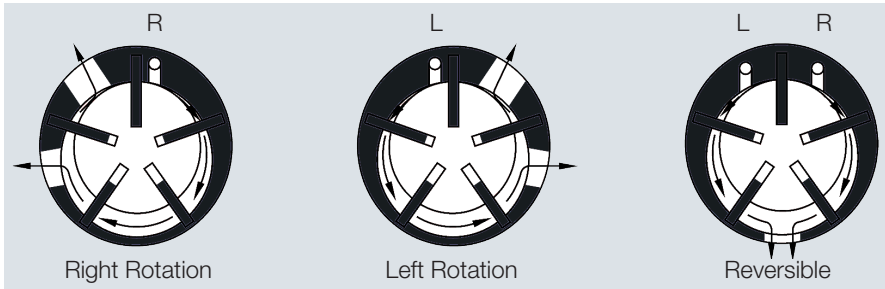

For motors with one turn direction, an increased turn angle for the expansion of the air is available. Therefore, these motors reach a somewhat higher efficiency.

The total efficiency-grade is essentially defined by the leak-loss on the front end of the motor. Highest production tolerances ( $\leq 0.01$  mm) are essential for the unique performance density of the DEPRAG vane motor.



Depending on application requirement, the rotor contains 3 to 6 vanes. A higher vane quantity results in a greater start safety at higher friction losses. The tangential array of the vanes, provides a larger vane height and with it higher motor endurance. Virtually all DEPRAG air motors include a specialized surface treatment of the rotor cylinder, which increases the vane life span.

In practice, vane motors have shown to keep a relatively constant orbital speed, which is, according to motor design, between 25 and 30 m/sec. The idle speed of an air motor essentially depends on the motor-diameter.

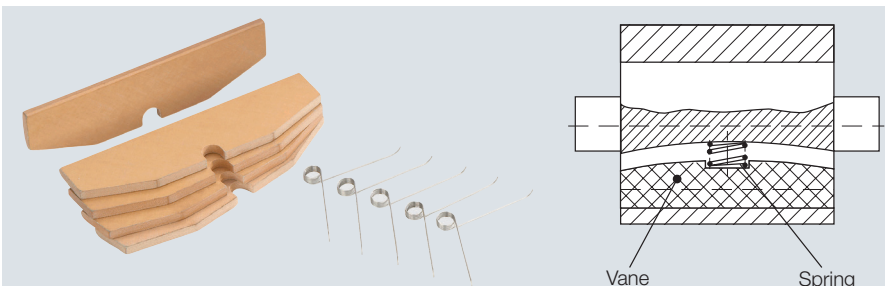

Vane motor with automatic start

### Starting conditions

During the operation of an air motor, the vanes are pressed against the wall of the rotor cylinder by the centrifugal force, which seals the working chambers against each other. If there are special requests in regard to the start-torque, suitable measures must be met to guarantee an automatic start.

For example:

- spring-loaded vanes
- pin-guided vanes
- thrust-rings
- vacuum induction, etc.

With the above options, it is possible to achieve a start-torque, which is approximately 1.5fold of the nominal torque.

## Air quality and oil-free operation

### Oil-free operation

All DEPRAG ADVANCED LINE stainless steel motors from series 67 are suitable for oil-free operation. They fulfil the special requirements of the food processing industry and are equally suitable for application in clean-rooms.

It must be noted that oil-free operation can reduce the output of the air motor by 10-20 % depending on design.

### Operation with lubricated air







Lubricated operation always improves a motors life span and operational behavior. For a correct air preparation, dryers and maintenance-units, existing of filter and oiler, are available.

In regard to air quality according to ISO 8573-1, we recommend:

	Cl.	Residue of Oil Content		Residue of Dust			Residue of Water		
		mg/m <sup>3</sup>	oz./cu.ft.	particle size mm	mg/m <sup>3</sup>	oz./cu.ft.	pressure dew-point °C	g/m <sup>3</sup>	oz./cu.ft.
Dry Air	3	1	1.03 · 10 <sup>-6</sup>	0.005	5	5.14 · 10 <sup>-6</sup>	-20	0.88	0.90 · 10 <sup>-3</sup>
Lubricated Air	4	5	5.14 · 10 <sup>-6</sup>	0.015	8	1.03 · 10 <sup>-6</sup>	+3	5.953	6 · 10 <sup>-3</sup>

## ATEX KENNZEICHNUNG

<b>A =</b>		 II 2G Ex h IIC T6 Gb X  II 2D Ex h IIIC T80 °C Db X
<b>B =</b>		 II 2G Ex h IIC T5 Gb X  II 2D Ex h IIIC T95 °C Db X

<b>C =</b>		 II 2G Ex h IIC T4 Gb X  II 2D Ex h IIIC T130 °C Db X
<b>D =</b>		 II 2G Ex h IIC T3 Gb X  II 2D Ex h IIIC T195 °C Db X

## Explosion prevention

With the guideline DIN EN ISO 80079-36:2016 the qualification of air motors for the use in EX-environments must be proven.

The type examination certificate from an independent test facility guarantees the user safe use of our air motors in the non-mining sector of device category 2

- Gases/vapours G, suitable for zone 1 and 2
- Dusts D, suitable for zone 21 and 22.

For substances which fall under explosion group IIC, the permissible surface temperatures stated in the catalogue apply.

The max. surface temperature for explosion category IIIC (conductive, flammable dust) can be found in the second line of the ATEX classification.

The markings can be found in the corresponding product catalog.

The world's first ATEX conform complete system, consisting of **air motor, holding brake and planetary gear** can be found as a standard product in the ADVANCED LINE air motor program for 20 W - 1.6 kW stainless steel airmotors.

Details can be found on page 12.

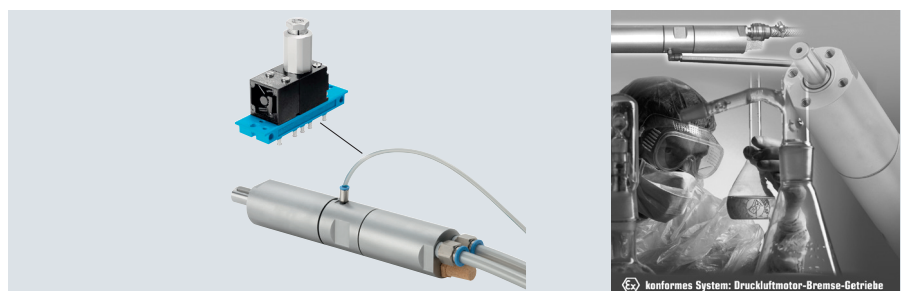

## Comparison of drive principles

HYDRAULIC MOTOR	AIR MOTOR	ELECTRIC MOTOR
<ul style="list-style-type: none"> <li>• may be loaded until full standstill</li> <li>• overload safe</li> <li>• operationally safe (dust, gas, water)</li> <li>• weight</li> <li>• high power density</li> <li>• output-to-size ratio</li> </ul>	<ul style="list-style-type: none"> <li>• may be loaded until full standstill</li> <li>• overload safe</li> <li>• torque increase at mounting load</li> <li>• low installation cost</li> <li>• maintenance friendly</li> <li>• explosion proof</li> <li>• operationally safe (dust, gas, water)</li> <li>• low weight and small size</li> <li>• high power density</li> <li>• can be sterilized</li> </ul>	<ul style="list-style-type: none"> <li>• cost</li> <li>• total used energy</li> <li>• noise level</li> <li>• maintenance intervals</li> <li>• adjustability</li> </ul>
<ul style="list-style-type: none"> <li>• danger of oil leakage</li> <li>• hydraulic pack necessary</li> <li>• high installation costs</li> </ul>	<ul style="list-style-type: none"> <li>• total used energy</li> <li>• noise level</li> <li>• maintenance intervals</li> </ul>	<ul style="list-style-type: none"> <li>• risk of failure at overload</li> <li>• safety risk of any electrical installation</li> <li>• high weight</li> <li>• large size</li> </ul>

### Comparison Air Motor / Electric Motor

Frequently, the unfavorable total energy use is seen as a disadvantage of the air motor. That the air motor has nevertheless asserted itself in the entire drive technology as an essential alternative, emphasizes its numerous advantages. When compared with the total cost estimate of the machine, the energy consumption plays no crucial role, especially when small drives with low duty cycles are used.

#### Design size

The main advantage of the air motor is its high performance density, which is only about 1/5th of the mass or 1/3rd of the size of an electric motor of comparable performance. This is particularly important with all hand-held machines, but also with robotic-systems or CNC-machines, where the drive has to be indexed.

#### Power characteristics

The power output performance of the air motor is virtually constant over broad speed ranges. It can also be operated in a wide field of alternating loads. The power output can be easily adjusted by changing the operating-pressure, and the speed is perpetually variable, by the reduction of air volume.

#### Load capacity

The air motor can easily be loaded to a full standstill; it even tolerates a negative turn direction if the load is increased. The motor always reaches its full power output and there will be no damage to the motor! The air motor starts again immediately, once the load is removed and this consecutively, even when motor operates without a pause.

#### Temperature behaviour

Expanding air cools the motor when the load is increased. Only when idling, a rise in temperature may occur. The motor is therefore temperature insensitive and overheating through over load is practically impossible.

#### Safety

Air is an unproblematic energy carrier. There are no dangers from electricity or temperature increases e.g. in potentially explosive environments.

#### Maintenance

Air operated drives are extremely robust. The internal overpressure prevents the penetration of dust or dirt. Only the low cost vanes need to be exchanged as wear parts. Necessary repairs are simple and can be done easily and safely by a trained maintenance person. No electricity specialist is necessary.

Further details and valuable hints can be taken from our catalog D0090E „Preventive maintenance and repair of air-operated tools.“

# Characteristic curve of the Air Vane Motor

## Performance

A parabolic performance curve results from the linear torque process, with the maximum output at nominal speed. This output maximum is identified according to the nominal speed, as the nominal power output. Each operating point below the nominal power output is reached with 2 speeds, which lie symmetrically to the output maximum. Therefore, the air motor cannot be selected for performance alone, but in the first place according to the necessary torque, as well as the corresponding speed.

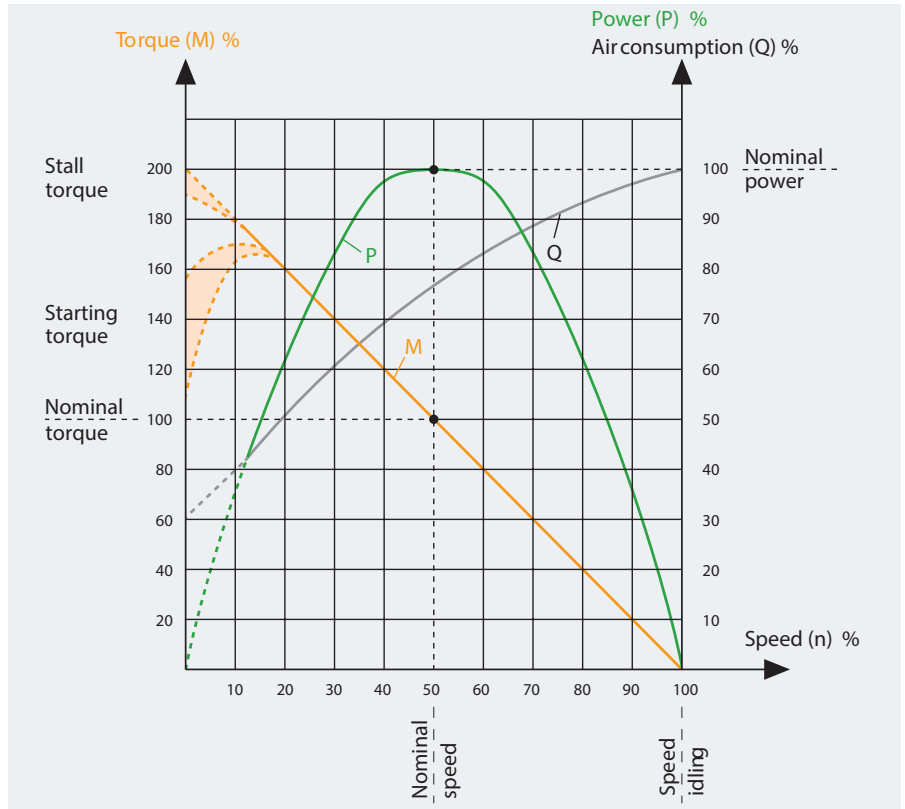

Characteristics of the air vane motor

## Torque

The torque of unadjusted vane motors increases, at constant operating pressure, almost linearly with decreasing speed. The air motor can easily be loaded to a full standstill, where it reaches the so-called stationary or stall torque. The theoretical stall torque corresponds approximately to double the nominal torque, reduced by the standstill loss, in practice to about 1.9fold of the nominal torque.

The so-called startup or starting torque against the load, is lower than the stall torque. It depends on the vane array at the start-up time. The fluctuation amounts to approximately 100 to 150 % of the nominal torque.

## Speed

With vane motors, speeds of up to 80,000 rpm can be reached.

The idle speed of an air motor can be set in a wide speed range of approx. 15 - 100 %

## Air consumption

The air and with it the energy consumption, is determined by the leak loss and the output from chamber volume, chamber number and speed. The air consumption increases with the speed and reaches its maximum with the unloaded speed. Vane motors usually cite a specific air consumption per kilowatt of 1.4 m<sup>3</sup>/min at smaller motors, up to 1 m<sup>3</sup>/min at bigger motors.



# Infinite variable regulation of the air pressure or air volume

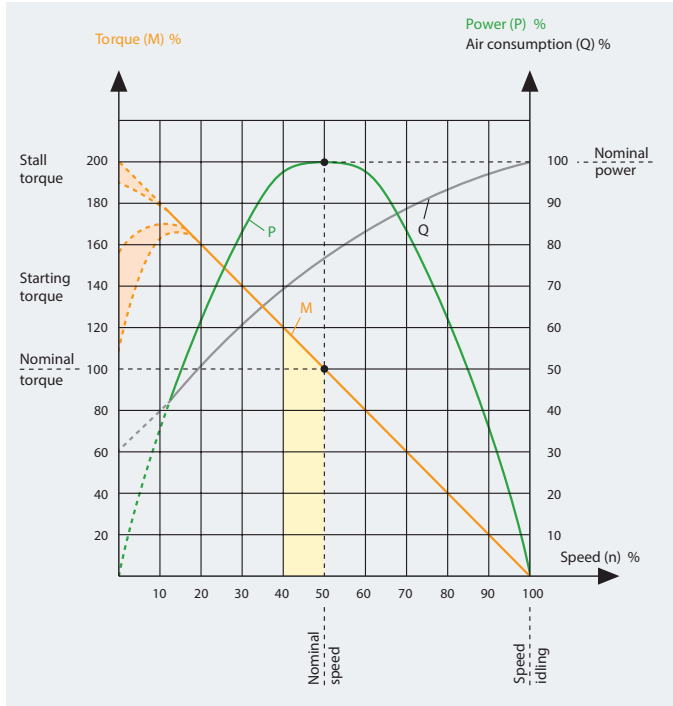

Your air motor is very flexible: The speed can be variably adjusted to fit your requirement. The speed change can be achieved by varying the air pressure, or by changing the air volume or as commonly used by a combined regulation of air pressure and air volume.

## Speed change through load change:

The speed of the air motor automatically adapts to the load changes: This means that at no load, the air motor operates at no-load speed. If there is increased load (low torque) the nominal speed is close to the no-load speed. With increased load (increased torque), the speed decreases.

## Energy Efficiency:

An pneumatic motor achieves its maximum power when it is operating as close as possible to its rated speed (50% of the rated idle speed). The energy balance is best in this area, because the compressed air is used efficiently. Theoretical power curves are available for all DEPRAG pneumatic motors. Please ask us for additional information.

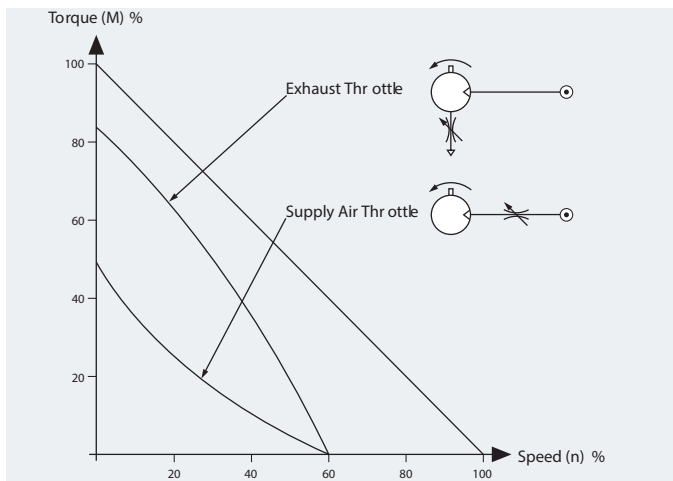

## Regulating the speed by air volume:

Through throttling the exhaust air, a speed reduction of the pneumatic motor is achieved without any considerable loss of performance or torque. On the other hand, if you would like to also reduce the power output or the torque in addition to the speed, then an air-inflow throttling is recommended.

## Regulating the speed by air pressure:

The operating data of the DEPRAG air motor is based on an operating air pressure of 6 bar. By adjusting the pressure in the range of 4 to 6.3 bars you can manipulate the speed, power, torque and air consumption of your pneumatic motor without problems. The following correctional factors are applicable to achieve the desired adaptation:

Torque / speed reaction with air regulation

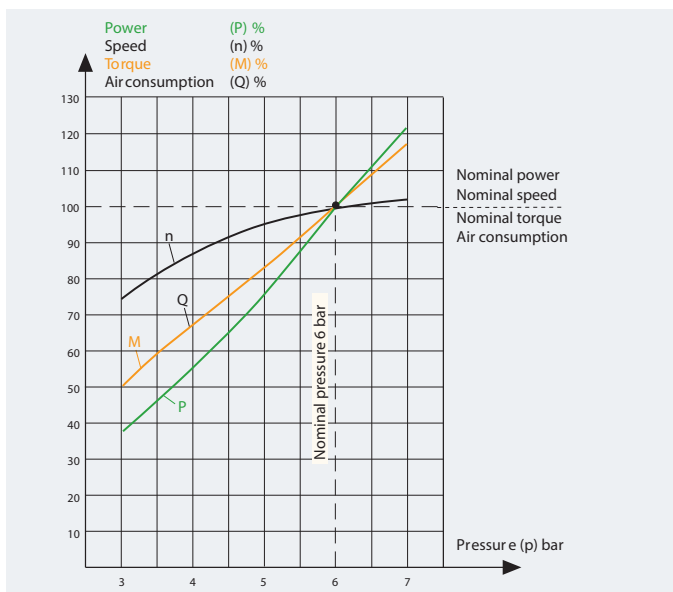

Pressure (p)	Power (P)	Speed (n)	Torque (M)	Air consumpt. (Q)
bar/PSI	%	%	%	%
7 / 99	121	103	117	117
6 / 85	100	100	100	100
5 / 71	77	95	83	83
4 / 57	55	87	67	67
3 / 42	37	74	50	50

# Installing your Air Vane Motor

## Air Connections

If you connect your air motor, do not close the second inlet-connection (reverse port) and the exhaust port. This allows your motor to start unimpeded.

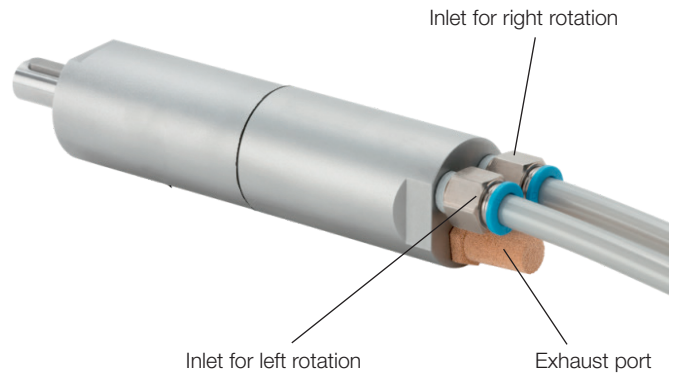

**Turn direction:** view from air inlet

## Connection control diagrams for the control of our air motors

To control an air motor in one direction a simple 2/2-way valve is all that is needed.

Air motors that are reversible (i.e. into two turn-directions), can also be controlled by a simple flow-valve, if the motor contains an integrated, manual reverse lever (for example: POWER LINE high-performance motors).

Otherwise, a 5/3-way valve or alternatively two 3/2-way valves are needed, so that the unused inlet can be exhausted.

When using any valves, make sure to pay attention to the minimum required hose-ID and that the valve allows for the a sufficient flow-rate as shown for each motor in our product catalog.

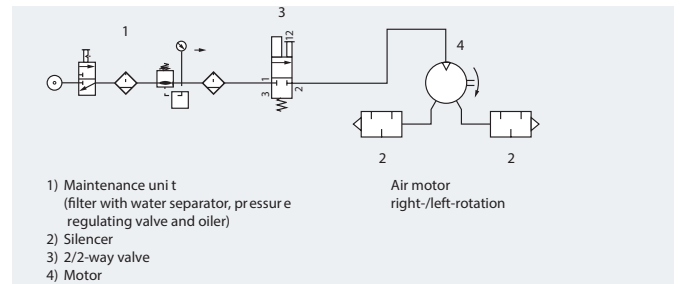

If the air motor is used in one turn-direction only, then it should be operated with a 2/2-way valve

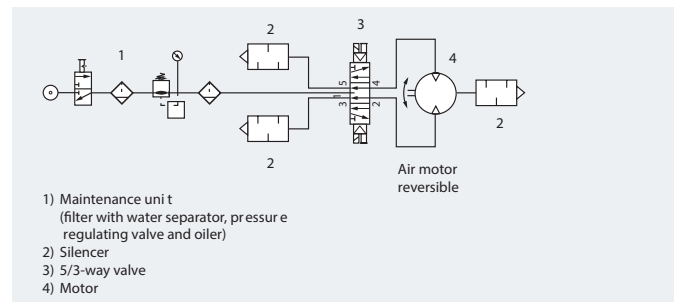

If the motor needs to be used with reverse, then it should be operated with a 5/3-way valve

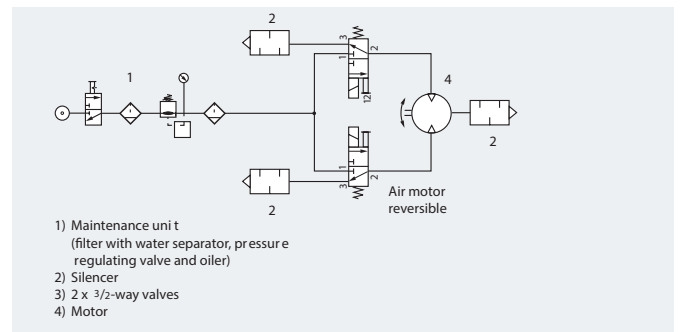

The air motor can also be used with two 3/2-way valves if operated with reverse

# Selecting an Air Motor for your application

Are you looking for a suitable motor for your construction?

The following guide will help you to avoid annoying mistakes which could drive up running costs later.

This is the correct procedure for selecting your drive:

## STEP 1:

### WHICH DRIVE PRINCIPLE IS SUITABLE FOR YOUR APPLICATION?

Air motors are available in various designs. The deciding factor in your choice is the application and the intended operating life-span.

The air vane motor is suitable for regular operating cycles. However tooth-gear motors or turbines are more suitable for continuous operation (24 hour, non-stop) of the planned machine.

#### Speeds:

Turbines and tooth-gear motors rotate in the upper speed range (up to 140,000 rpm). Air vane motors are available for very small speeds e. g. 16 rpm.

#### Oil-free operation

is an option for all three basic principles. It is available for all ADVANCED LINE air motors of the series 67 taking into consideration the possible reduction of power 10 - 20 %.

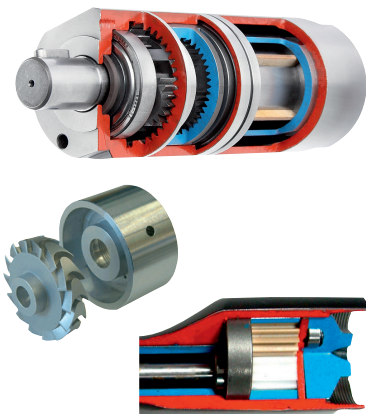

## STEP 2:

### WHICH MOTOR MATERIAL IS SUITABLE FOR YOUR APPLICATION?

The material and design of the motor is decided according to your individual application. DEPRAG offers much more than the catalogue standards with drive solutions adapted to your application, so that your motor provides reliable service for you for as long as possible.

#### Normal production operation

In dry environments and for standard operating procedures, an air motor made from cast-iron is the right solution. Here, we can offer the wide product range of the DEPRAG BASIC LINE air motors. For integration with robots or into machines, we offer a multitude of grinding-, milling-, and drill-motors, which excel through their low weight and compact design.

#### Paper industry

For use in the paper industry a stainless steel design is required. DEPRAG ADVANCED LINE motors satisfy the high demands of this field.

#### Food processing industry

Air motors used in the food industry must be resistant to cleaning agents and water vapor. The DEPRAG ADVANCED LINE air motors are fully sealed and all seals are made from resistant materials.

#### Chemical industry

Air motors for the use in the chemical industry have to be resistant to aggressive chemicals. Please tell us the chemicals that the air motor comes in contact with and we select the suitable material to manufacture your air motor. Especially in this industry, an air motor has to be explosion proof. Your DEPRAG air motor made from stainless steel fulfills the ATEX norm and is additionally fully sealed.

#### Underwater usage

When using an air-motor under water, its performance depends on how you operate your air motor and at what depth. If the motor is started outside of the water and subsequently submerged in water up to a depth of 20-meters, then the DEPRAG ADVANCED LINE air motors made from stainless steel can be used.

If the air motor starts below the water surface, then our ADVANCED LINE air motors can be used up to a depth of 5-meters. If you have more difficult requests or would like to use the air motor in saltwater, then, further additional modifications have to be made to the housing material, to seals and to the coating of interior parts - please contact us with more details.

#### Medical technology Pharmaceutical industry

Air motors in the medical and pharmaceutical industries work in sterile conditions. Special materials ensure a long life-span despite frequent sterilisation of the complete air motor.

#### Potentially explosive areas

In potentially explosive environments air motors are the first choice due to their design and functionality. The expanding compressed air cools the motor as it works. However extra combination with gears and brakes could increase risks. Therefore for this application DEPRAG offers the world's first ATEX conform complete system of air motor, brake equipment and gears.

#### Have you found your application?

We are happy to advise you in your individual application needs.

#### Example:

An air motor made of glass ceramic – a non-ferritic drive system for use in magnet resonance therapy.





# Selecting an Air Motor for your application

## STEP 3:

### HOW DO YOU CALCULATE THE MOTOR POWER TAKING THE APPLICATION CONDITIONS INTO CONSIDERATION?

The correct calculation of your required drive is influenced by the required torque, the optimal working range of your air motor, the necessary motor power and possibly any application conditions which affect performance.

#### (1) Rotational direction

Determine the required rotational direction:

- clockwise
- anti-clockwise
- reversible

View from air inlet in the direction of motor shaft.

#### (2) Optimal working range of the Air Motor

Air motors function in a very broad working range which can be decisively influenced by the amount of supplied air and the air pressure.

Next determine the working position for your motor:  
Which nominal torque and which speed (when loaded) do you want to reach?

The most economical operation of the air motor (least wear, least air consumption, etc.) is reached by running close to nominal speed.

By torque of  $M = 0$ , the maximum speed (idle speed) reached.

Shortly before standstill ( $n \rightarrow$ ), the air motor reaches its maximum torque ( $M_{max} \approx 2 \times M_n$ ).

At nominal speed ( $n_n$ ), i. e. in the middle of the speed range, the air motor reaches its maximum power output ( $P_{max}$ ).

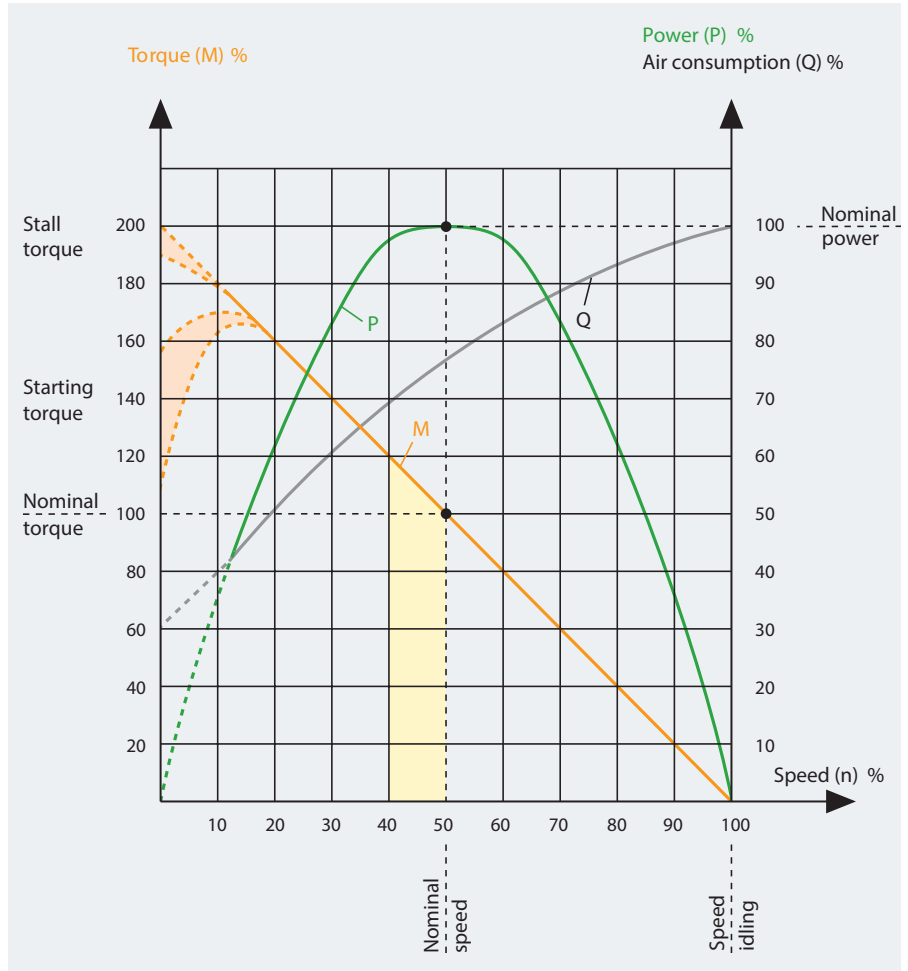

= optimal working range of the air motor

#### (3) Calculating the motor power

Next calculate the basic performance data of your motor, which will be adjusted in connection with your framework conditions (operating pressure available, opening cross-section, oil-free operation).

$$P = \frac{M \times n}{9550}$$

**P = Power output in kW**  
**M = Nominal torque in Nm**  
**n = Nominal speed in rpm**

**Power [HP] = P [kW] x 1.34**  
**Torque [in.lbs] = M [Nm] x 8.85**

#### (4) Allowing for performance influencing application conditions

All performance specifications of DEPRAG air motors are based on an operating pressure of 6 bar. Operating pressure means the flow pressure directly at the air motor.

The catalogue specified inner opening cross-section of the supply hose (and all connection pieces and valves) as well as the length of the supply hose (max. 3 metres) of each motor influences the performance calculation.

The catalogue specifications are also based on lubricated operation. Oil-free operation results in reduced performance (see subsection "c").

# Selecting an Air Motor for your application

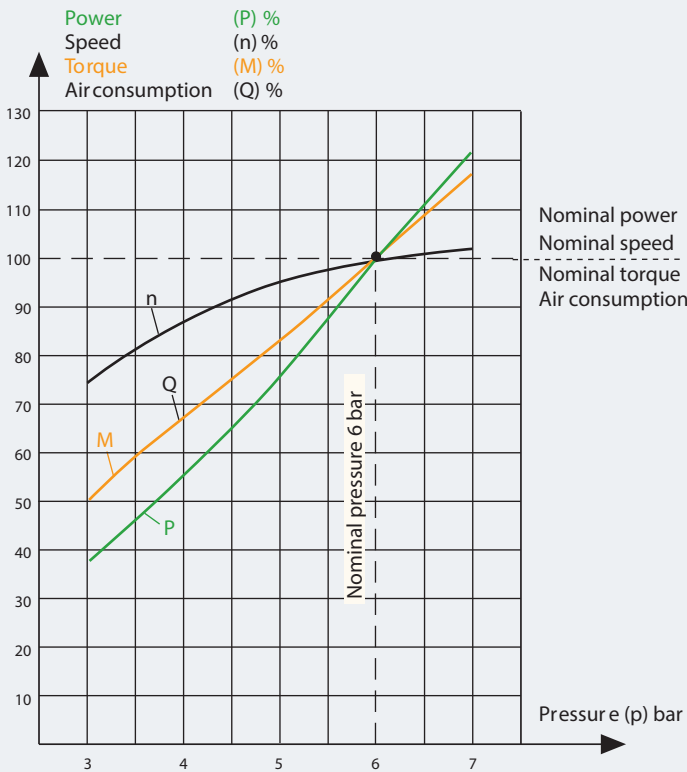

Pressure (p) bar / PSI	Power (P) %	Speed (n) %	Torque (M) %	Airconsumpt. (Q) %
7 / 99	121	103	117	117
6 / 85	100	100	100	100
5 / 71	77	95	83	83
4 / 57	55	87	67	67
3 / 42	37	74	50	50

Influences of the operating pressure

If your application conditions differ from this basic data then the performance data of your motor should be corrected as follows:

### a) Allowing for a different operating pressure

To adapt the differences in operating pressure you can either use the correctional diagram on the right or the correctional table.

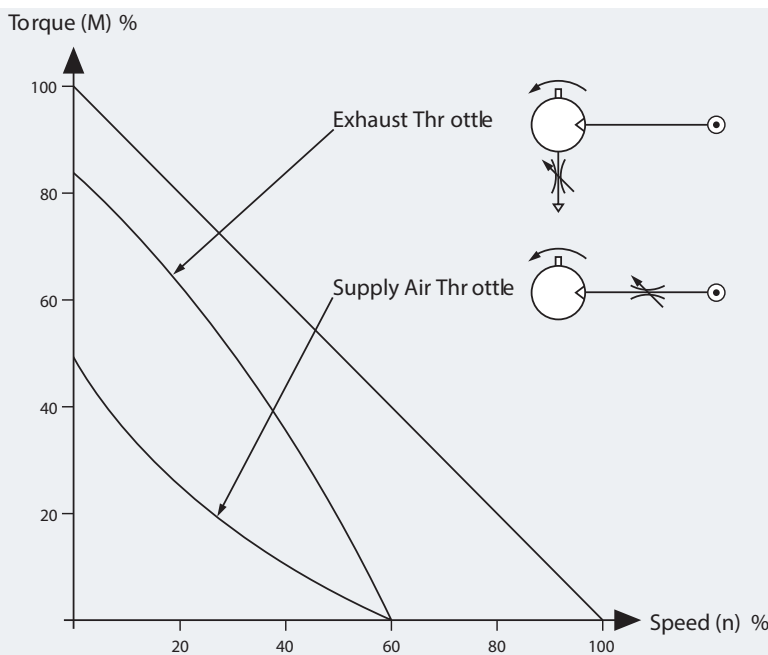

Influence of the air quantity

### b) Allowing for opening cross-section

Every size reduction of the opening cross-section, whether of the supply hose itself or connection pieces, affects the amount of supplied air. On a standard motor you can adapt the amount of air to fit your needs by throttling if required.

For all our air motors there is a characteristic line available. Just ask us to provide one!

By throttling you reduce the speed of your motor and simultaneously, the required torque: that means that you reduce the motor performance. By exhaust throttling, on the other hand, you can set the speed of the motor without great loss of the torque.

## Selecting an Air Motor for your application

### c) Allowing for oil-free operation

The optimal life-span and performance of an air motor is reached by 1-2 drops of oil per 1m<sup>3</sup> air consumption.

The air consumption data for each motor can be taken from the product catalog.

For oil-free operation an additional performance loss of 10 - 20 % must be calculated.

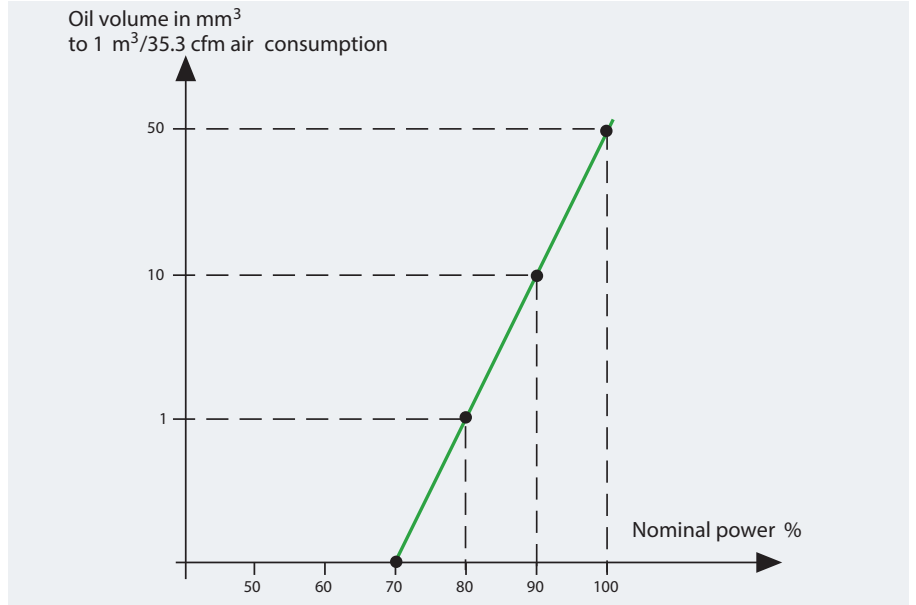

### Are you having trouble determining your performance data?

Contact our application consultants – they will be glad to help you!

### Would you like to calculate the performance data of your existing drive?

We offer a comprehensive testing service to determine the performance data of your existing drives (air motors, hydraulic or electric drives, grinding machines, drill machines, etc.).

Using our modern test facility we can determine performance parameters, speed, torque, operating pressure, air consumption and air humidity in

Speed range of:  
0 - 12,000 rpm  
and  
torque range of:  
0 - 500 Nm  
with accuracy of 0.1 % of the nominal torque.



### STEP 4:

### HOW DO YOU INTEGRATE THE AIR MOTOR INTO YOUR COMPLETE SYSTEM?

Once you have chosen your air motor you can add extra components which are available from DEPRAG's standard programme.

#### (1) Integrated brake equipment

For example, if a brake needs to hold the position of a barrel during a tipping process, then a DEPRAG standard system can accommodate this requirement.

#### (2) Integrated gear solution

A complete solution is often better value for money than searching for a gear solution yourself. DEPRAG offers a comprehensive range of motors with integrated planetary gears, worm gears or spur gears.

A worm gear is recommended when your system's gears need to be selflocking. A planetary gear allows a changeable installation position for smaller sizes.

Even if you can not find the right model in our catalogue, we have lots of great value special solutions available.

#### (3) Fixture and connection size

We offer numerous individual fixture options as well as those in our catalogue, so that our air motor fits perfectly into your machine.

Tell us your requirements, we can implement them for you at low-cost.

#### (4) Technical examination

How does the power of your planned system affect the motor's drive spindle? The maximum allowable axial and radial loads can be found in our catalogs.



# Selecting an Air Motor for your application

## STEP 5:

### HOW CAN YOU ENSURE LONG LIFE-SPAN AND HIGH PERFORMANCE OF YOUR MOTOR?

Air motors are extremely high performance machines and therefore have a long-life-span and are robust.

Adhering to the following framework conditions ensures the highest possible life-span and best performance of a motor:

- keep to the recommended air quality (dry supply air, free of particles)
- optimum life-span and best performance is achieved with 1-2 drops of oil per 1 m<sup>3</sup> air consumption
- keep to the recommended maintenance intervals (for oil-free operation please allow for shorter periods between maintenance intervals)
- sufficient opening cross-section of the air supply hose and the connection fittings
- maximum length of the air hose 3 metres
- operate the motor within its optimal working range, i.e. near to nominal speed

How frequently an air motor should be maintained is dependent on many factors. The application environment and conditions play an important role, also the size of gears or torque range. Additionally the duty cycle of the air motor must be considered.



Here is a useful tip to remember when your pneumatic motor will not be used for a long time: add a drop of oil to the air inlet and let the motor run for 5-10 seconds. Then the motor is well prepared for standstill or storage and will run again easily when restarted.

## STEP 6:

### HOW CAN YOU DETERMINE THE PURCHASING AND RUNNING COSTS?

The purchase price is the main factor to consider when buying a new drive system.

However, the follow-up costs must not be forgotten.

The operating costs for maintenance and service should also be taken into account when deciding to buy an air motor.

The cost of running the motor depends on air consumption. The correct choice of motor sets you on the right path for low running costs. The closer the motor is running to its nominal speed, (50 % of idle speed) i.e. the maximum performance of the motor is reached, the more efficiently the air will be used.

### Replacement parts and maintenance kits

Already when planning and selecting new equipment the question of fast availability of replacement parts and their price arises.

DEPRAG air motors stand out from the rest because of their extremely competitive replacement parts.



### Maintenance and repair service

DEPRAG additionally provides a package offer for maintenance and repairs which makes your follow-up costs easily calculable.



### Time is money – how easy is it to maintain your motor?

The DEPRAG BASIC LINE motor is particularly service friendly:

Due to our QuickVChange vane exchange system the air motor's vanes can be exchanged directly on the machine with just a few movements. Lengthy periods of standstill because of maintenance work on your machine are eliminated.

#### QuickVChange Vane Exchange System

**Exchange the vanes directly on the machine – fast and convenient**

## Do you need support in selecting the right drive system?

Tell us your operational conditions and our application consultants will be happy to help:

<b>Application:</b>	<input type="text"/>		
<b>In what kind of environment will the motor be installed?</b>	<b>ATEX requirement / explosion safety?</b>	<input type="checkbox"/> yes	<input type="checkbox"/> no
	if yes, which safety class:	<input type="text"/>	
	<b>food industry conformity?</b>	<input type="checkbox"/> yes	<input type="checkbox"/> no
	<b>sterilisable?</b>	<input type="checkbox"/> yes	<input type="checkbox"/> no
	<b>acid resistant?</b>	<input type="checkbox"/> yes	<input type="checkbox"/> no
	<b>steam resistant?</b>	<input type="checkbox"/> yes	<input type="checkbox"/> no
<b>Application conditions:</b>	<b>constant operation (24 hrs, non-stop)</b>	<input type="checkbox"/> yes	<input type="checkbox"/> no
	<b>duty cycle in hrs/day:</b>	<input type="text"/>	
	<b>days/year:</b>	<input type="text"/>	
	<b>cycle time (s):</b>	<input type="text"/>	
	<b>motor loaded to stall?</b>	<input type="checkbox"/> yes	<input type="checkbox"/> no
	<b>self-locking?</b>	<input type="checkbox"/> yes	<input type="checkbox"/> no
<b>Required turn direction:</b>	<input type="checkbox"/> left	<input type="checkbox"/> right	<input type="checkbox"/> reversible
	(view from air inlet)		
<b>Motor performance:</b>	<b>power:</b>	<input type="text"/>	W
	<b>nominal torque:</b>	<input type="text"/>	Nm
	<b>nominal speed:</b>	<input type="text"/>	rpm
<b>Performance influencing application conditions:</b>	<b>operating pressure (at motor inlet):</b>	<input type="text"/>	bar
	<b>operation with lubricated air possible?</b>	<input type="checkbox"/> yes	<input type="checkbox"/> no
	<b>smallest opening cross-section of connection pieces and hoses?</b>	<input type="text"/>	mm
<b>External motor design:</b>	<input type="checkbox"/> standard steel	<input type="checkbox"/> non-corrosive	<input type="checkbox"/> aluminium
	<input type="checkbox"/> plastics	<input type="checkbox"/> ceramics	
	<b>other:</b>	<input type="text"/>	
<b>Drive spindle design:</b>	<b>drive shaft requirements:</b>	<input type="text"/>	
	(e. g. keyed shafts, square end, hexagonal, collet, drill chuck taper, etc.)		
	<b>mounting dimensions:</b>	<input type="text"/>	
<b>Motor fixture design:</b>	<b>mounting requirements:</b> (bracket, flange, etc.)	<input type="text"/>	
	<b>required dimensions:</b>	<input type="text"/>	
<b>Additional components:</b>	<input type="checkbox"/> holding brake	<input type="checkbox"/> operational brake	
	<b>gear box:</b>	<input type="text"/>	
<b>Price range:</b>	<input type="text"/>		
<b>Annual requirement:</b>	<input type="text"/>		



**Do you require support for the needed layout of a turbine generator that lets you recover energy?**

Please give us details of your application and our specialists will recommend a suitable product:

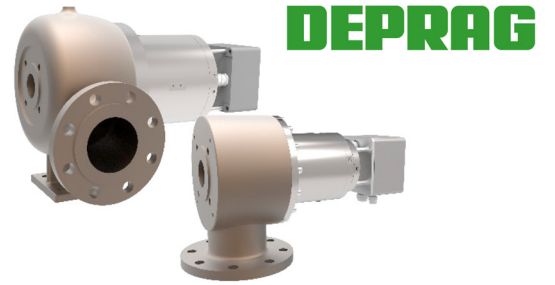

<p><b>Application / Process description:</b></p>	
<p>* <b>Medium (type of gas, fluid):</b></p>	
<p>* <b>Inlet pressure (absolute)</b></p>	
<p>* <b>Outlet pressure (absolute)</b></p>	
<p>* <b>Inlet temperature or outlet temperature</b></p>	
<p>* <b>Mass flow or required electrical power</b></p>	
<p><b><u>Operating conditions:</u></b> Duty cycle in hours per year</p>	
<p><b><u>Demand:</u></b> Annual usage Costing / Budget</p>	
<p><b><u>Personal data:</u></b></p>	
<p>* <b>Name</b></p>	
<p>* <b>Company</b></p>	
<p><b>Street</b></p>	
<p><b>ZIP / City</b></p>	
<p>* <b>Country</b></p>	
<p><b>Phone</b></p>	
<p>* <b>Email</b></p>	
<p><b>Web page / URL</b></p>	

\* mandatory field



# DEPRAG

**DEPRAG SCHULZ GMBH u. CO. KG**

P.O. Box 1352 | D-92203 Amberg

Carl-Schulz-Platz 1 | D-92224 Amberg

Phone: +49 9621 371-0 | Fax: +49 9621 371-120

[www.deprag.com](http://www.deprag.com) | [info@deprag.de](mailto:info@deprag.de)

CERTIFIED AS PER DIN EN ISO 9001

---