

## Ergonomic Tool Handling with or without Position Control

Perfectly coordinated stand and gantry solutions guide the screwdriving tool securely to the assembly position and take the strain off the operator.

Position control systems ensure that at the right place, at the right time, the correct connection element is assembled to the correct torque.



**Optional Systems**

For tool handling with position control	<b>Page 3</b>
For tool handling without position control	<b>Page 3</b>

**Applications****Page 4****The Position Control Stand / the Position Control Gantry****Page 4****With Position Control**

Position control stand - description/technical data	<b>Page 5/6</b>
Accessories for position control stand/dimensions/combination options	<b>Page 6/7</b>
Position control gantry - description/technical data	<b>Page 8</b>
Accessories for position control gantry/combination options	<b>Page 8/9</b>

**Without Position Control**

Linear stand	<b>Page 10</b>
Accessories for linear stand	<b>Page 10</b>
Parallelogram stand	<b>Page 11</b>
Rail-guided torque relief arm	<b>Page 11/12</b>
Swivel-arms, balancer stand, Telescopic torque arm	<b>Page 12/13</b>
Screwdriver stand	<b>Page 14</b>

**Accessories**

Balancers, hose balancers, spiral hoses	<b>Page 15</b>
Screwdriver adapter for electric screwdrivers	<b>Page 16</b>
Screwdriver adapter for pneumatic screwdrivers	<b>Page 16</b>
V-mounting bracket and more accessories (support rings, handles)	<b>Page 17</b>

### Tool Handling with Position Control

**Optional systems:**

- Position control stand
- Position control gantry

**Notes:**

- Monitoring of the screw position and screw sequence, freely programmable
- Individual screw tightening parameters available for each screw position
- Takes the strain off the operator by absorbing the reaction torque
- Vertical screwdriver guidance
- Optionally with integrated vertical stroke to relieve the operator. The pressure is activated by a cylinder.
- Sequential ordering of the connection elements according to position

### Tool Handling without Position Control

**Optional systems:**

- Linear stands
- Rail-guided torque relief arms
- Parallelogram stands
- Balancers

**Notes:**

- Takes the strain off the operator by absorbing the reaction torque
- Vertical screwdriver guidance
- Optionally with integrated vertical stroke to relieve the operator. The pressure is activated by a cylinder.



### Example: Assembly of electronic components

#### Components of the work station

- Position control gantry
- Aluminium base frame
- Automatic screw feeding using sword feeder
- CleanFeed concept for technical cleanliness
- Intuitive Pick-to-Light feeding module
- EC-Servo screwdriving system
- Toolbox bit exchange system
- DCOS control system

#### Notes:

- Ensures Technical Cleanliness
- Monitors screw position and screw sequence
- Automatically assigns the type of connection element and screw program to the screw position
- Torque and angle control
- Data recording and storage in data bank, connection to data management system
- ESD capability



### Example: Assembly of sunglasses

#### Components of the work station

- Parallelogram arm
- Aluminium base frame
- Intelligent workpiece fixtures with visual indication on screwdriver housing (green = pass / red = fail)
- Automatic screw feeding via vibratory spiral bowl
- Torque evaluation via integrated measurement equipment
- DCOS control system

#### Notes:

- Displays the status of assembly for the operator directly at the screw location
- Recognises and confirms presence of all required components
- Checks the number of screw assemblies per component
- Numerous communication interfaces

**Functionality**

The best process reliability can be achieved with the use of a position control stand/position control gantry which coordinates, optimises and controls the complete production process.

The stand/gantry can be operated with screwdrivers of the EC or EC servo series. They enable free programming of the screw tightening – torque, angle, speed, waiting time and rotational direction are individually adapted to the screwdriving task. The integrated torque and angle recording enables the exact control of the screw tightening as well as the documentation of important processing parameters. The position recognition feature increases processing reliability in applications where several screw positions need to be assembled in a certain order on one product. As soon as the position control stand/position control gantry is in the correct position screw tightening will begin. Equipped with guidance hardware and software, the stand/gantry will only allow activation of the correct function once situated in the correct position.

The position control is able to guide inputs and outputs depending on the application. This includes functions such as clamping and locking workpieces, feeding connection elements and activating measurement functions. If there are a large number of screw positions the position control stand /position control gantry can be used to determine and monitor the relevant operating mode required and the order of positions, the screw can only be tightened if the worker has kept the order in the correct sequence.

**Control and Visualisation of the Position Control Stand**

The integrated electronics provide comprehensive options for control of the assembly process and contain the following components:

- Linux based mini PC
- 24V inputs and outputs (for PLC, toolbox and AST11)
- HDMI connection for a standard PC monitor
- Ethernet bushing for the integrated web server
- Serial interface for fieldbus module (optional accessories)
- Connections for up to 3 position sensors
- Connection for part sensor
- 4 LEDs for status signals

There are four LEDs on the base stand displaying the status of the procedure, they signal the status of the screw assembly, a correctly assembled position is displayed



as green, an incorrectly assembled position as red and further work on the workpiece is prevented until the error is sorted and corrected by the operator. Only then can the operator carry on and assemble the next screw position. An orange LED indicates the “power signal” and blue is for “system ready”.

The position control stand can be used with the following operating modes:

- stand-alone operation with AST11 sequence controller
- stand-alone operation with AST11 sequence controller with toolbox

The operator can upload an image of the product and using program creation with “teach mode” each screwdriving position on the image can be indicated by the stand at the actual original positions. Up to 1000 screwdriving positions can be set per program whereas the number of possible programs in operation with the input and output interface is limited to 120 programs and 120 screw positions.

- operation with MICROMAT-F/MINIMAT-F screwdriver with additional pneumatic controller pc11/pc20
- operation with external fieldbus module (ProfiBus, ProfiNet, EtherCat, EthernetIP)

**Process visualisation**

The monitor, used for visualisation of the process, can be connected via the HDMI on the base stand of the position control stand. The monitor gives the operator exact instructions and shows in colour which positions on the product have already been assembled. If the screwdriver mounted on the stand is at the pre-set X-Y coordinate, then this is marked on screen in colour and with a text display “OK” or “NOT OK”. The lit up status LEDs on the base stand also inform the operator of the current status of the screw assembly.

The web interface is used for adjustment of the processing sequences where the operator can adjust all settings as well as setting controller configurations.

An additional module “processing display web interface” can also display the current status in quasi real time on the HDMI monitor. This enables assembly processes to be monitored on a remote PC or via smartphone or tablet.

**Control and Visualisation of the Position Control Gantry**

The position control gantry functions via a processing and system controller (DCOS). Further details and technical data for the DCOS can be found in our brochure D3350E.

Our technical consultants are happy to help with your configuration.

## WITH POSITION CONTROL

### Position control stand – coordinates, optimises and controls the complete production process

#### Advantages:

- increased process reliability
- control of processing steps
- visualisation via monitor
- integrated electronics into the base stand
- high ergonomics

#### Technical data – Position control stand

integrated electronics into the base stand				with analog output at the base stand				Technical data	
axes: X, Y		axes: X, Y, Z		axes: X, Y		axes: X, Y, Z			
Type	Part no.	Type	Part no.	Type	Part no.	Type	Part no.	For torque reaction up to Nm/in.lbs	Weight of horizontal arm kg/lbs
PKS20	448000A	PKS20-Z	448000D	PKS20-A	448000G	PKS20-A-Z	448000J	20/177	2.3/5.06
PKS50	448000B	PKS50-Z	448000E	PKS50-A	448000H	PKS50-A-Z	448000K	50/443	8.9/19.6
PKS150	448000C	PKS150-Z	448000F	PKS150-A	448000I	PKS150-A-Z	448000L	150/1328	11.4/25.08

#### Required accessories for position control stand with integrated electronics into the base stand

Power supply	Type	PKS-EU	PKS-US	PKS-CN
	Part no.	102329A	102329B	102329C
Source (AC)	V/Hz	100-240 / 50/60		
Output (DC)	VDC	24		

More required accessories: balancers (see page 15) and screwdriver adapter or V-mounting bracket (see pages 16/17).

#### Optional equipment for position control stand

Designation	Part no.	Suitable for	Weight kg/lbs	Note
Interface fieldbus external (FBC4) Profibus	428010A	PKS types with integrated electronics		
Interface fieldbus external (FBC4) Profinet	428010B			
Interface fieldbus external (FBC4) Ethercat	428010C			
Interface fieldbus external (FBC4) EthernetIP	428010D			
Connection cable PKS ↔ fieldbus controller FBC4	101291A			
Connection cable PKS ↔ sequence controller AST11	101289A			
Connection cable PKS ↔ pneumatic controller pc11	101293A			
Connection cable PKS ↔ Toolbox TB7	101294A			
Ceiling support	426540A	PKS20/-Z/-A/-AZ		For better stability of the stand and increased precision the easy to install ceiling support can be attached.
Ceiling support	426540B	PKS50/-Z/-A/-AZ PKS150/-Z/-A/-AZ		
Horizontal drawback	379822O	PKS20/-Z/-A/-AZ	0.5/1.1	This clamping unit is used in combination with the DEPRAG FEED MODULE (DFM). The adapted design of the clamping unit fits seamlessly with the position control stand.
Horizontal drawback	379822P	PKS50/-Z/-A/-AZ PKS150/-Z/-A/-AZ	0.5/1.1	
Clamping unit vertical	426878A	PKS20/-Z/-A/-AZ	0.4/0.88	
Clamping unit vertical	426878B	PKS50/-Z/-A/-AZ PKS150/-Z/-A/-AZ	3.1/6.8	
Clamping unit with cylinder stroke 140mm, vertical pressure 120N at 6 bar/85psi	413144I	PKS20/-Z/-A/-AZ	1.4/3.1	For use without DFM the servo support functions in the same way as on the linear stands via clamping unit with integrated cylinder.
Clamping unit with cylinder stroke 130mm, vertical pressure 290N at 6 bar/85psi	413144J	PKS50/-Z/-A/-AZ PKS150/-Z/-A/-AZ	6.3/13.9	
Suitable pressure regulator valve	968299A	Clamping unit with cylinder		to set the cylinder power
Monitor with touch feature	104363	PKS types with integrated electronics		12.1" / resolution 1280 x 800
Connection cable PKS ↔ Monitor with touch feature	104709			
Software WEB-VISU-POSI (release code)	101890			process visualization via web interface

More optional equipment: intelligent software packages combined with standardised hardware - please find details on page 8.

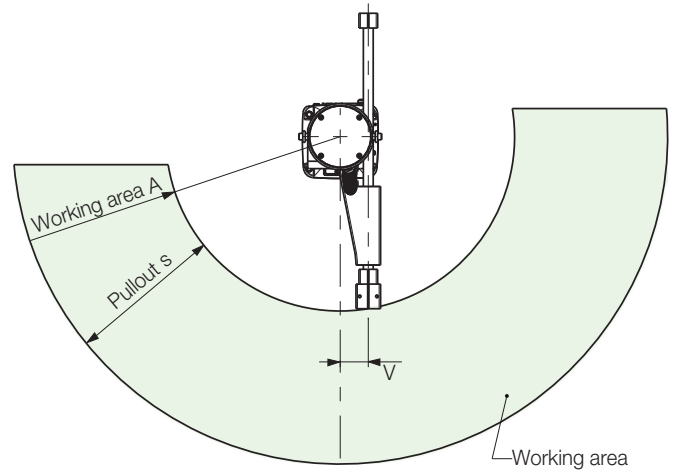
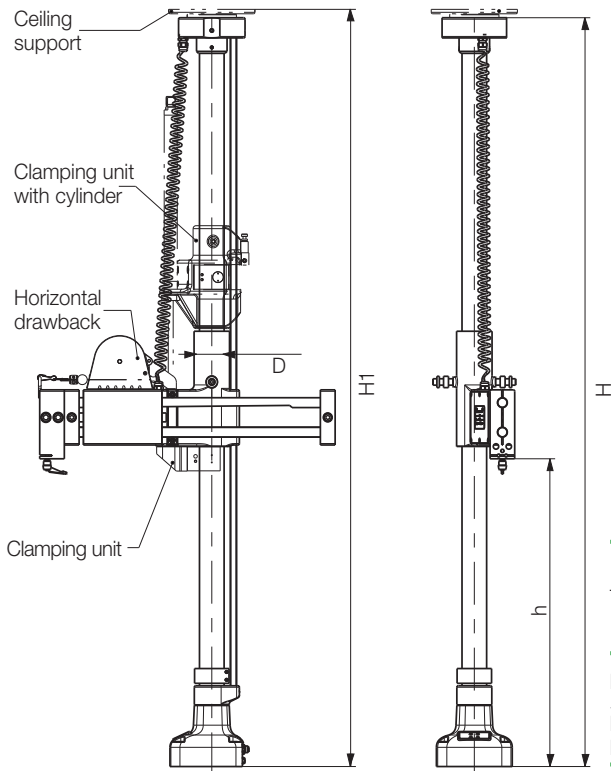

Type	Working area A mm/in.	Pullout s mm/in.	Offset V mm/in.	Column-Ø D mm/in.	Height h mm in.	Height H mm in.	Height H1 mm in.
PKS20/-Z/-A/-AZ	320/12.5	235/9.2	30.5/1.2	20/0.78	137-1073 5.3-41.8	1266 49.37	1283 50
PKS50/-Z/-A/-AZ PKS150/-Z/-A/-AZ	350/13.65	313/12.2	57/2.2	50/1.95	170-1190 6.6-46.4	1521 59.32	1538 60

p448005

Optional equipment to combine with the position control stand

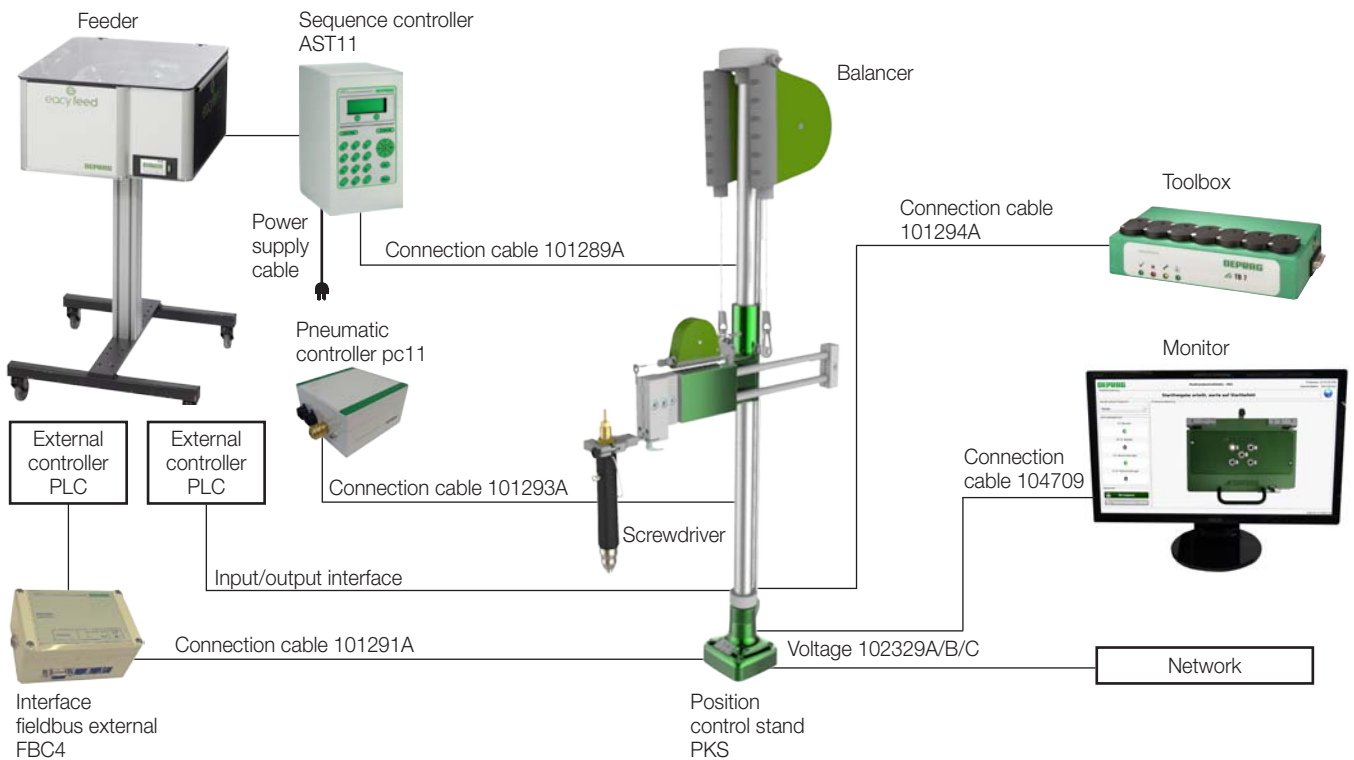

Please consider both the weight of the horizontal arm and of the screwdriver in order to select the appropriate balancer. We highly recommend the use of two balancers to spread the total weight more evenly.

## WITH POSITION CONTROL

### Position control gantry – for position control of tools in manual workstations

#### Advantages:

- increased process reliability
- control of processing steps
- high ergonomics through
  - easy accessibility and clear view of the screw positions
  - tool weight offset by the balancer
- high repeatability
- increased user friendliness due to significantly reduced movement of mass

#### Technical data – Position control gantry

Position measuring system X/Y	incremental, non-contact, magnetic		
Optional: position measuring system Z	incremental, cable rope position measuring device		
Maximum travel distance (X/Y/Z)			
for handheld screwdrivers	mm/in.	850/740/310	/ 33.15/28.86/12.1
for DEPRAG FEED MODULE	mm/in.	710/670/310	/ 27.69/26.13/12.1
Outer dimensions (WxD) basic version	mm/in.	1100 x 1060	/ 42.9 x 41.34

The abovementioned travel distance indicates the maximum value. In practice the exact version is adjusted to your requirements. Please contact us to discuss.

#### Optional equipment for position control gantry (also suitable for position control stand)

##### Intelligent software packages

DFUN	DVIP	DPRO	DAST	DSPEC
DFUN10 no. 815454		DPRO10 no. 815632		Part no. based upon order
DFUN50 no. 815455	DVIP50 no. 815629	DPRO50 no. 815633		
DFUN100 no. 815456	DVIP100 no. 815630	DPRO100 no. 815634	DAST100 no. 815641	
DFUN200 no. 815457	DVIP200 no. 815631	DPRO200 no. 815635	DAST200 no. 815642	

Intelligent software packages combined with standardised hardware based on an industrial PC enable individual solutions tailored to your application. Perfectly coordinated interfaces between standard components and an intuitive operator guidance guarantee the best in user friendliness. Our technical consultants are happy to help develop your set-up. Additional information can be found in brochures D3390E and D3350E.

#### The standardised software packages:

##### DFUN DEPRAG FUNction

combines and controls all standard functions on the manual work station



##### DVIP DEPRAG Vision and Position

position control guidance and visualisation of the assembly tasks

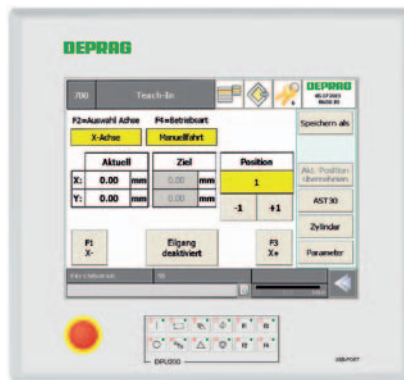

##### DPRO DEPRAG PROcess

processing control and data handling (product data acquisition, machine data logging, manufacturing execution systems, Industry 4.0)



##### DAST DEPRAG AblaufSteuerung

operation of all EC screw-driver sequence controllers centrally via DCOS operator panel



##### DSPEC DEPRAG customer SPECification

the software solution customised to your specific application

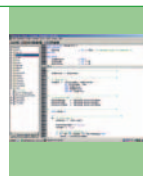



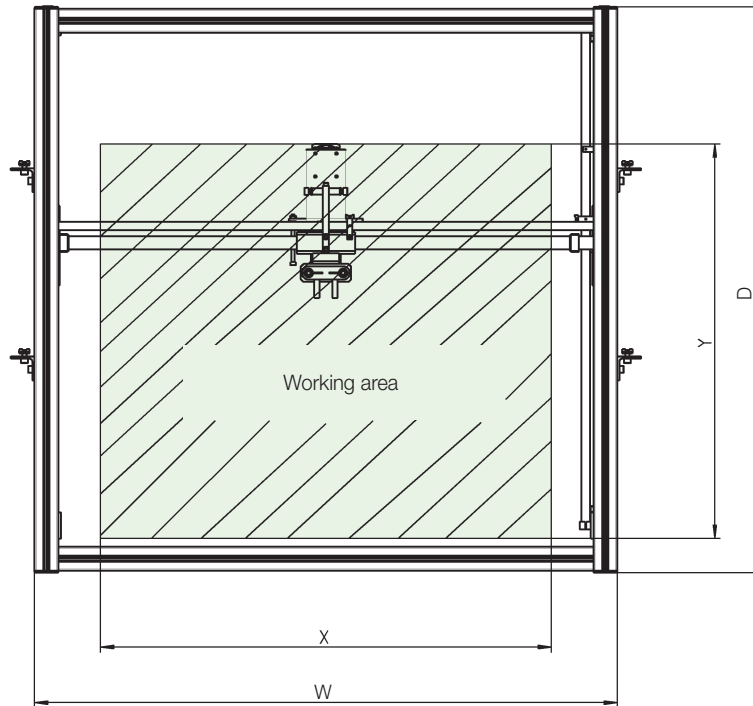

Optional equipment to combine with the position control gantry

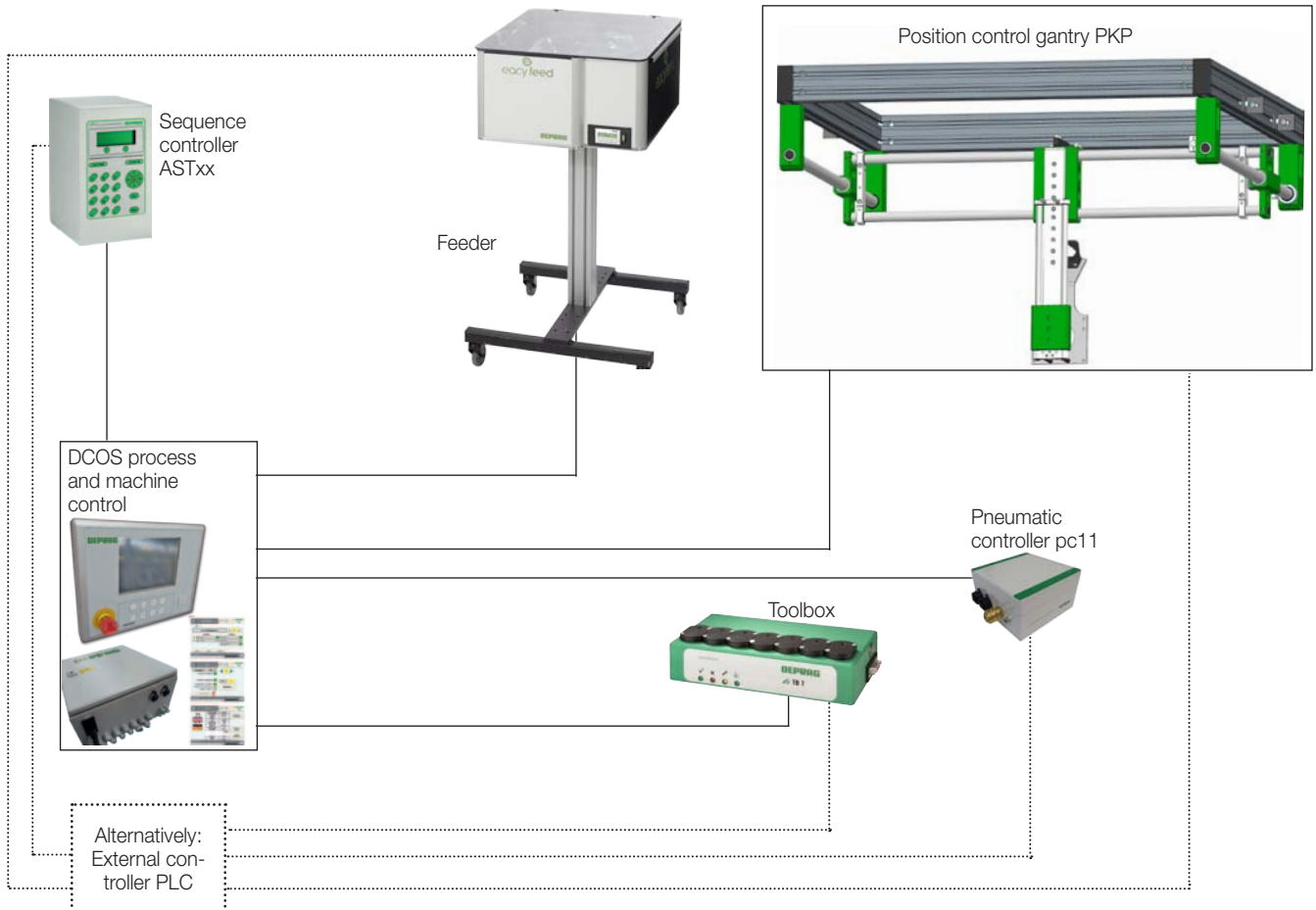

Please consider both the weight of the Z axis and of the screwdriver in order to select the appropriate balancer. We highly recommend the use of two balancers to spread the total weight more evenly.

Linear stand – for ergonomic and process reliable tool guidance

Advantages:

- user friendly
- ergonomic
- support of the tool weight
- fast and secure positioning

**DEPRAG linear stand for ergonomic process reliable guidance of your tool, used to support the tool weight and for fast and secure positioning.**

Please contact us if you require a special linear stand for e.g. ceiling suspension, with longer extension or with locking mechanism.

Technical data – Linear stand

For torque reaction up to Nm / in.lbs	Working area A mm/in.	Pullout s mm/in.	Grid dimension R mm/in.	Column-Ø D mm/in.	Height h mm/in.	Height H mm/in.	Weight of horizontal arm kg/lbs	Part no.
for screwdriver, straight								
20 / 177	217-329 / 8.5-12.8	242 / 9.4	28 / 1.1	20 / 0.78	115-1082 / 4.5-42.2		2 / 4.4	408010A
50 / 443	222-348 / 8.6-13.6	342 / 13.3	42 / 1.6	30 / 1.17	185-1014 / 7.2-39.5	1220 / 47.58	6.7 / 14.7	408010B
150 / 1328	279-383 / 10.9-14.9	324 / 12.6	52 / 2.0	50 / 1.95	194 - 983 / 7.6-38.3		13.7 / 30.1	408010C

for ESD screwdriver, straight								
20 / 177	217-329 / 8.5-12.8	242 / 9.4	28 / 1.1	20 / 0.78	135-1102 / 5.3-43	1240 / 48.36	2 / 4.4	408010D
50 / 443	222-348 / 8.6-13.6	342 / 13.3	42 / 1.6	30 / 1.17	205-1034 / 8 -40.3		6.7 / 14.7	408010F

Required accessories: balancers (see page 15) and screwdriver adapter or V-mounting bracket (see pages 16/17).

Optional equipment for linear stand

Designation	Part no.	Suitable for	Weight kg/lbs	Note
Horizontal draw back	379822N	Linear stand no. 408010A	0.5 / 1.1	
Horizontal draw back	379822L	Linear stand no. 408010B	1 / 2.2	
Horizontal draw back	379822M	Linear stand no. 408010C	1 / 2.2	
Clamping unit with cylinder incl. start button	on request	Linear stands		takes up the contact pressure of the screwdriver and relieves the operator
Clamping unit vertical	on request	Linear stands		the clamping unit is only used in combination with the DEPRAG FEED MODULE (DFM) or the ERGOMAT-Z screwdriver

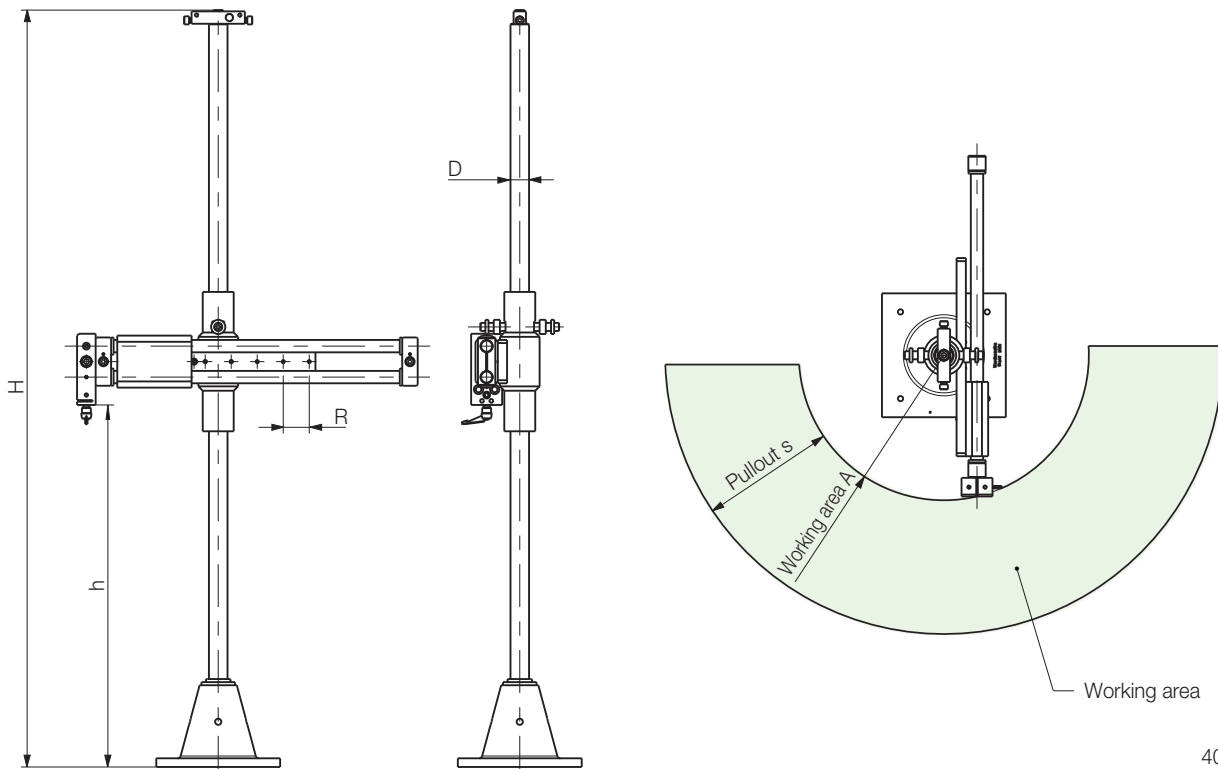

4002971

Please consider both the weight of the horizontal arm and of the screwdriver in order to select the appropriate balancer. We highly recommend the use of two balancers to spread the total weight more evenly. We recommend the use of linear stand 408010B for tools with total length ≥ 450mm and for screwdrivers size 2 in conjunction with our feeding systems.

# WITHOUT POSITION CONTROL

## Parallelogram stand - for screwdriver, straight

for torque reaction up to Nm/in.lbs	Capacity kg/lbs	Working area mm/in.	Height max. mm/in.	Part no.
45 / 400	0-2 / 0-4.4	150-610/5.85-23.8	600 / 23.4	406253A

**Required accessories:** Screwdriver adapter or V-mounting bracket (page 16/17).

Parallelogram stand with adjustable starting position, spring loaded.

## Additional swivel-arm - for parallelogram stand 406253A

Working area mm/in.	Part no.
250 / 9.75	347607
400 / 15.6	811733A

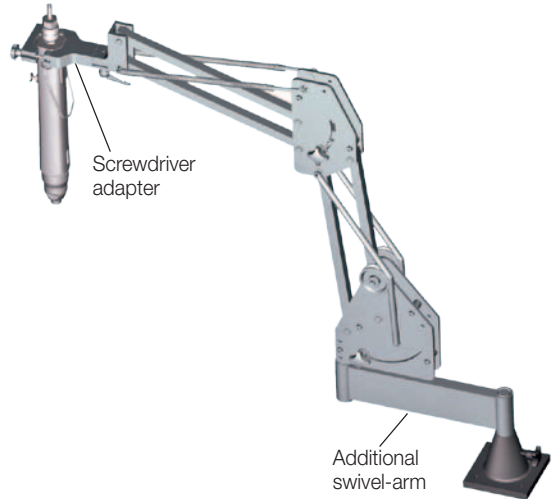

## Rail-guided torque relief arm - for screwdriver in straight version and pistolgrip, consisting of:

Pos.	Designation	Part no.
1	End stop	809911
2	Lateral stop (functions only in connection with elevation stop)	809912
3	Elevation stop	809913
4	Parallelogram arm with guide carriage	809914
5	Guide rail, length 1 m / 2 m / 3 m	8099151/8099152/8099153
6	Telescope holder	809907
7	Suitable screwdriver adapter	see page 16
8	Guide carriage (separate), with aluminium plate 100x100x20 mm	809910
4/2/3	Parallelogram arm with guide carriage, lateral- and elevation stop	809926A

This parallelogram arm is recommended for larger work areas above the workstation (ceiling-mount). The torque relief arm consists of the parallelogram arm with guide carriage (4), which slides on rails (5). An integrated axis in the guide carriage allows the arm to swivel. The end stop (1) prevents the derailing of the guide carriage at the end of the rails. The elevation stop (3) is required for the correct function of the lateral stop (2).

For the function of parallelogram arm (pos. 4) positions 1 / 2 / 3 and 5 are also necessary.

To hold screwdriver pos. 7 or pos. 6 together with pos. 7 are necessary.

Please find further information on page 12.

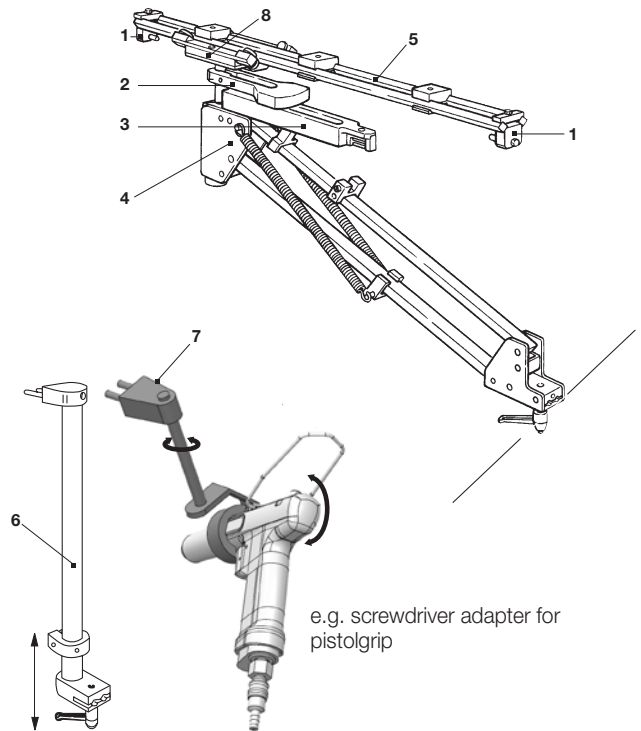

# WITHOUT POSITION CONTROL

## Further information about the rail-guided torque relief arm

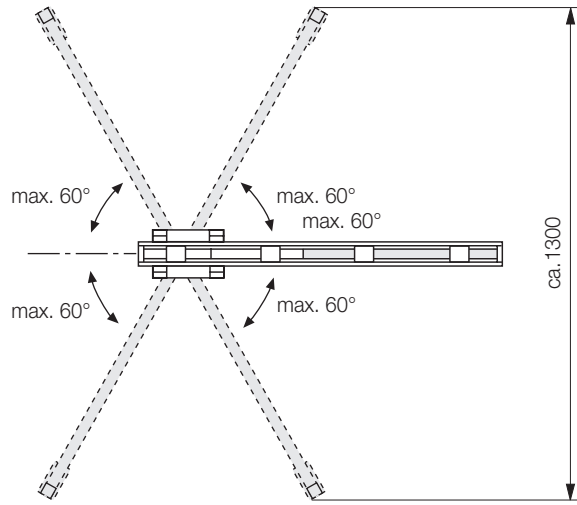
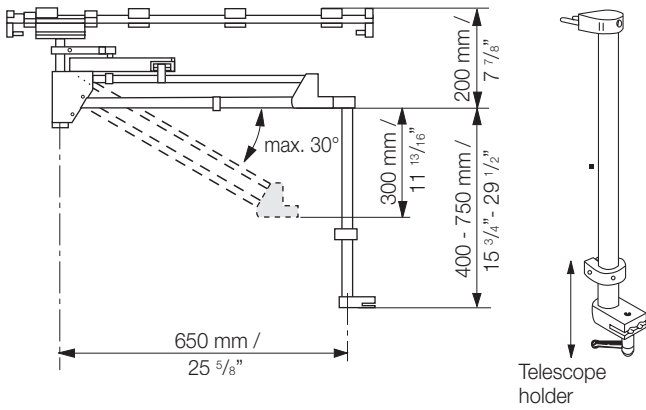

The rails are available in 1, 2 and 3 meter long pieces (3.3 ft., 6.6 ft. and 10 ft.). 3 meter long pieces (10 ft.) can be joined together. If the rails are installed high above the work station, the telescope holder should be used. This holder is adjustable in length from 400 mm (15 3/4 in.) to 750 mm (29 1/2 in.).

An angle larger than 60° between the rails and the parallelogram arm should be avoided, since it will result into sluggish positioning. Furthermore, it may also cause the guide carriage to move when reaching torque.

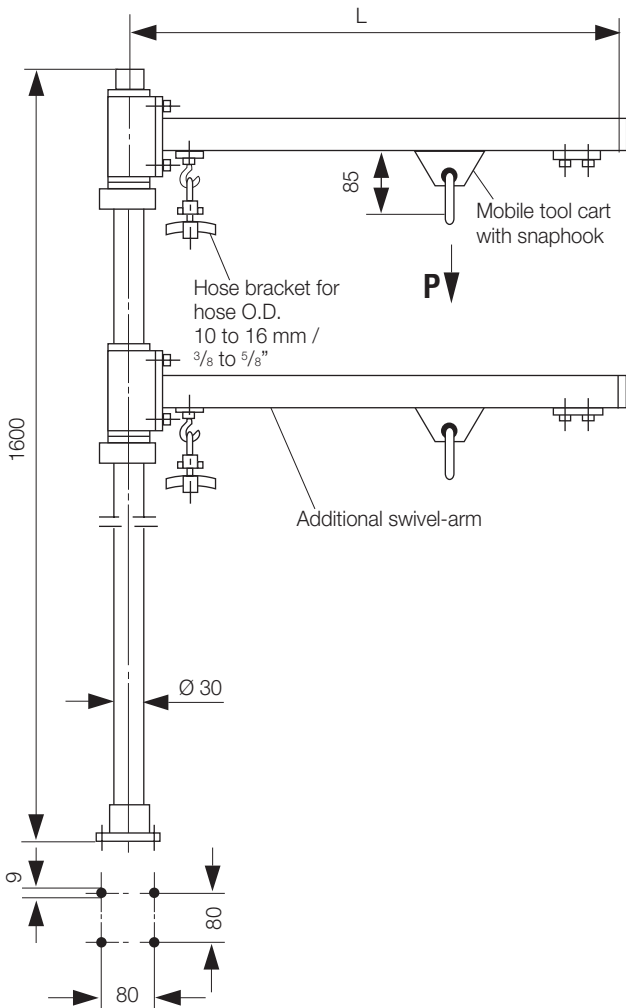

### Swivel-arm for table installation

Track profile C-rail 30 x 32 mm

Length (L) mm/in.	Capacity (P) kg/lbs	Part no.
630 / 24.57	16 / 35.2	811600A
1000 / 39	10 / 22	811627A

### Additional swivel-arm

Track profile C-rail 30 x 32 mm

Length (L) mm/in.	Capacity (P) kg/lbs	Part no.
630 / 24.57	16 / 35.2	811601A
1000 / 39	10 / 22	811630A

**Swivel-arm for wall installation**

Track profile C-rail 30 x 32 mm

Length (L) mm/in.	Capacity (P) kg/lbs	Part no.
630 / 24.57	20 / 44	811602A
1000 / 39	16 / 35.2	811731A

All swivel-arms are delivered with extended high arm tips. Through dismantling of a cone plate the arms can be set horizontally.

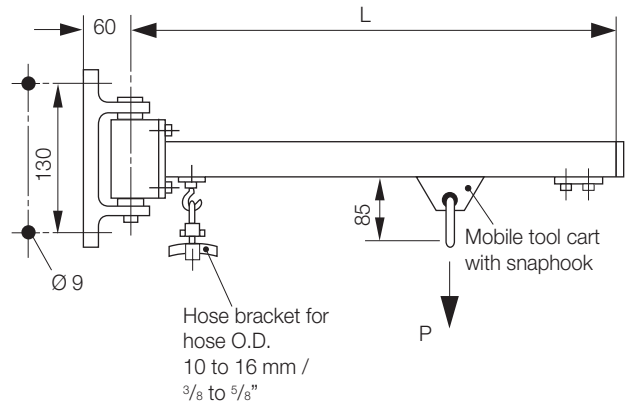

**Balancer stand**

for screwdriver straight (motor size 0)

Capacity kg/lbs	Working area mm/in.	Height mm/in.	Part no.
0.2-0.26/0.44-0.57	540-640 / 21-25	750 / 29.25	324348H
with maintenance unit and vacuum interruption for screw suction *)			
0.2-0.26/0.44-0.57	540-640 / 21-25	750 / 29.25	324348G
with maintenance unit, vacuum- and supply air interruption *)			
0.2-0.26/0.44-0.57	540-640 / 21-25	750 / 29.25	324348I

\*) Injector is optional equipment

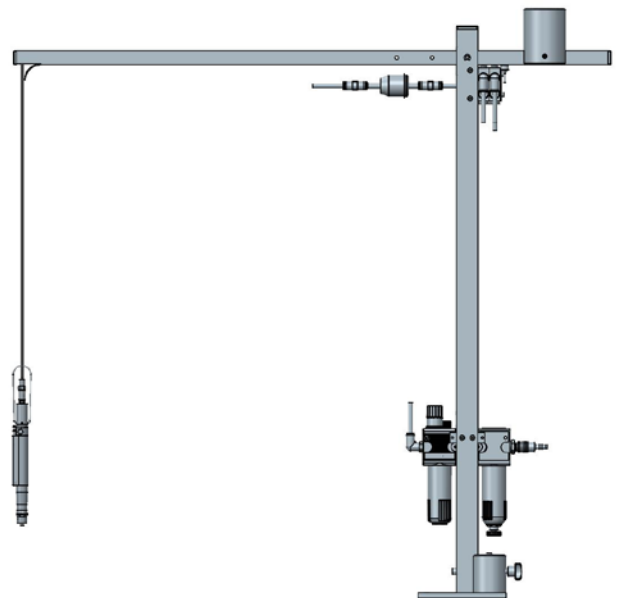

**Telescopic torque arm**

for screwdriver, straight

For torque reaction up to Nm/in.lbs	Working area mm/in.	Height max. mm/in.	Part no.	Weight kg/lbs
15 / 130	430- 925 / 16.77-36	-	408351A	1.14/2.5
22 / 195	540-1200 / 21 -46.8	-	408351B	1.6 /3.5

**Required accessories:**

Screwdriver adapter or V-mounting bracket (see pages 16/17). Please find suitable balancers on page 15.

**Optional equipment:**

Stand	400/15.6	408351C	1.3 /2.86
Clamping piece for pipe mounting (clamping range dia. 25 - 50 mm)	-	408351D	0.25/0.55

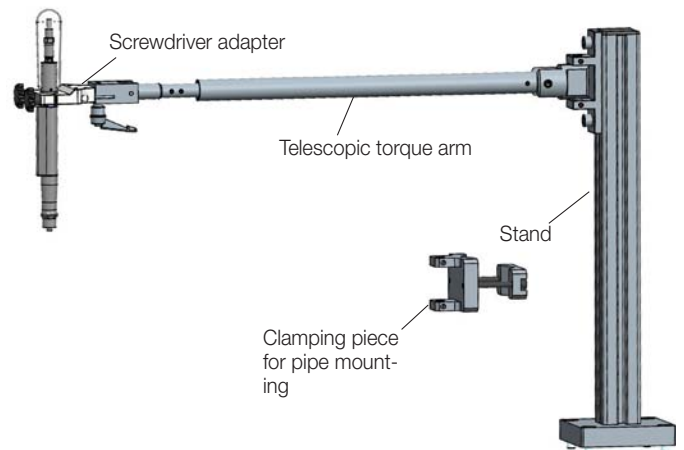

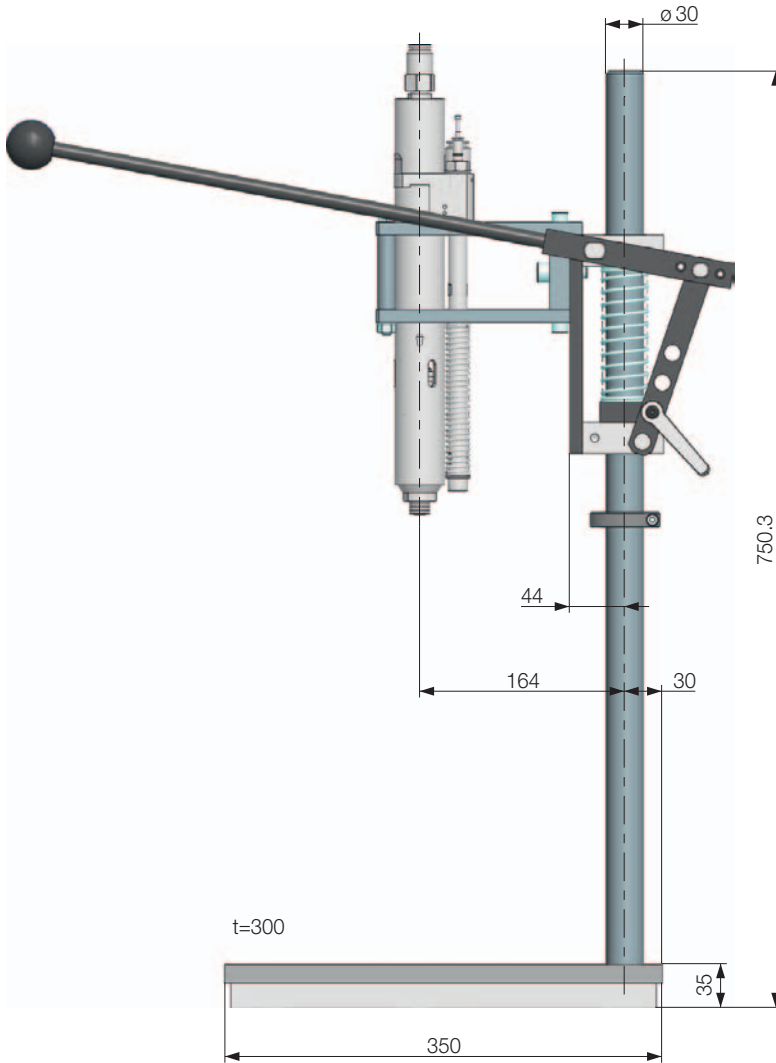

102715A

**Screwdriver stand**

Suitable for stationary screwdriver spindles	Screwdriver right-/left rotation Part no.	Screwdriver reversible Part no.
		335100A
for this screwdriver adapter (without spindle mounting hole) for pneumatic screwdrivers		
Motor size 0	336080A	336080A
Motor size 1	336080A	336080A
Motor size 2, without and with offset gearing	336080C	336080C
Motor size 3, without and with reduction gearing	336080C	336080C
Motor size 4	336080C	336080C
for this screwdriver adapter (with 1 spindle mounting hole) for pneumatic screwdrivers		
Motor size 0	336081	336081
Motor size 1	340995	340995
Motor size 2, without and with offset gearing	3380031	3380031
Motor size 3, without and with reduction gearing	326851	333953
Motor size 4	395717	395717
for this screwdriver adapter (without spindle mounting hole) for electric screwdrivers		
Series 320E22-..	336080A	336080A
Series 320E27-..	336080A	336080A
Series 320E36-..	336080A	336080A
for this screwdriver adapter (with 1 spindle mounting hole) for electric screwdrivers		
Series 320E22-..	340995	340995
Series 320E27-..	3380031	3380031
Series 320E36-..	326851	326851

\*) Screwdriver adapter for other screwdriver sizes upon request

**Balancers**

Capacity from - to kg/lbs	Max. cable travel m/ft.	Weight kg/lbs	Part no. with turnable snap hook	Part no. with holding plate for rigid mounting on the linear stand   position control stand
without vacuum interruption				
0 - 0.5 / 0 - 1.1	1.6 / 5.2	0.4 / 0.88	833320A	8333201A   8333202A
0.3 - 1.5 / 0.7 - 3.3		0.5 / 1.1	833320B	8333201B   8333202B
1.2 - 2.5 / 2.6 - 5.5		0.6 / 1.3	833320C	8333201C   8333202C
0.5 - 2 / 1.1 - 4.4	2.5 / 8.1	0.8 / 1.8	833390A	8333901A   8333902A
1.5 - 3 / 3.3 - 6.6		0.8 / 1.8	833390B	8333901B   8333902B
2 - 5 / 4.4 - 11	3 / 9.8	3.3 / 7.3	833395A	8333951A   8333952A
4 - 8 / 8.8 - 17.6		3.7 / 8.1	833395B	8333951B   8333952B
7 - 10 / 15.4 - 22		3.7 / 8.1	833395C	8333951C   8333952C
10 - 14 / 22 - 30.8	2 / 6.5	3.9 / 8.6	833395D	8333951D   8333952D
12 - 20 / 26.4 - 44		15.9 / 35	810350C	-   -
20 - 30 / 44 - 66		16.3 / 36	810351C	-   -
30 - 45 / 66 - 99		18 / 39.6	810352C	-   -
45 - 60 / 99 - 132		18.4 / 40.5	810353C	-   -
with vacuum interruption and integrated injector for screwdrivers with screw suction				
0 - 0.5 / 0 - 1.1	1.6 / 5.2	0.6 / 1.3	833402D	8334021D   8334022D
0.3 - 1.5 / 0.7 - 3.3			833402E	8334021E   8334022E
1.2 - 2.5 / 2.6 - 5.5			833402F	8334021F   8334022F
with conical rope barrel in order to balance the suspended load at any required pulling level				
0.4 - 1.2 / 0.88 - 2.6	1.5 / 4.9	1.3 / 2.9	828003A	-   -
1.2 - 2.6 / 2.6 - 5.7		1.4 / 3	828003B	-   -
2.6 - 3.8 / 5.7 - 8.4		1.5 / 3.3	828003C	-   -
3.8 - 5.2 / 8.4 - 11.4		1.5 / 3.3	828003D	-   -
5.2 - 6.5 / 11.4 - 14.3		1.5 / 3.3	828003E	-   -

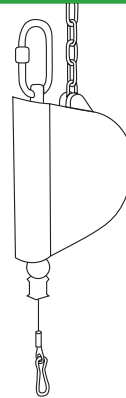

**Hose balancers**

Capacity from - to kg/lbs	Max. hose length m/ft.	Hose I.D. mm/in.	Air connection	Weight kg/lbs	Part no.
0.4 - 1.2 / 0.88 - 2.6	0.8 / 2.6	5 / 0.2	1/4" f / coupler 804251	1.2 / 2.6	824069A
1.2 - 2.2 / 2.6 - 4.8				1.3 / 2.86	824069B
2.2 - 3 / 4.8 - 6.6				1.4 / 3.08	824069C

With the DEPRAG balancers, tools, machines and parts can be suspended completely balanced, at any height and moved up and down effortlessly. The balancers are suspended in such a way that the required work height is within the available stroke height.

**Spiral hoses - for balancers with vacuum interruption**

Hose I.D. mm/in.	D mm/in.	L working area m/ft.	L fully extended max. m/ft.	Connection	Part no.
for supply air NANOMAT / MICROMAT screwdriver					
4 / 0.16	32 / 1.25	0.8 - 2 / 2.6 - 6.6	3 / 9.8	plug 801555/coupler 820301	346697D
for supply air MINIMAT screwdriver (motor size 1)					
4 / 0.16	32 / 1.25	0.8 - 2 / 2.6 - 6.6	3 / 9.8	plug 801555/coupler 820367	346697H
for supply air MINIMAT screwdriver (motor size 2)					
6 / 0.23	65 / 2.54	1 - 2.5 / 3.3 - 8.2	5 / 16.4	plug 323213/coupler 804282	346697K
vacuum hose with connection for injector (screwdriver motor sizes 00, 0, 1, 2, 2.5 and 3)					
4 / 0.16	32 / 1.25	0.8 - 2 / 2.6 - 6.6	3 / 9.8	plug 820366	346697J

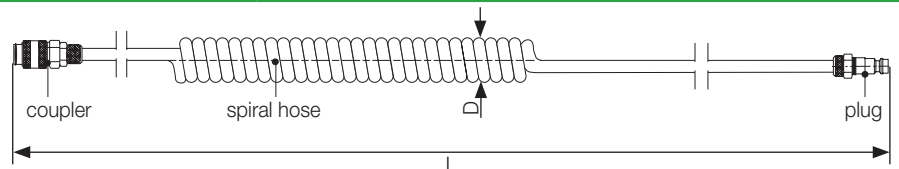

Please find further spiral hoses in our brochure D3340E on page 4.

# ACCESSORIES

## Screwdriver adapter for electric screwdrivers

Suitable for screwdriver style	Series	Screwdriver adapter, not turnable - standard version, Part no.
EC screwdriver NANOMAT-EC, straight	320E12-..	422035A
EC screwdriver MINIMAT-EC, straight	320E22-..	422040A
	320E27-..	3957112
	320EGx22-..	4008331U
	320EGx27-..	4008331U
	320EGA36-..	4008330
	320EGT36-..	101014A
EC screwdriver MINIMAT-EC, angle head design	320EWT27-..	4008331V
	320EWT36-..	400833W
Electric screwdriver, handheld, straight	342EGT-0003	4008330E
	342EGx-0012/...-0019	4008330B
	342EGx-0029/...-0049	4008330C
	342EGx-0088/...-0120	4008330D
Digital screwdriver MINIMAT-ED, straight	330EG36-..	103557A

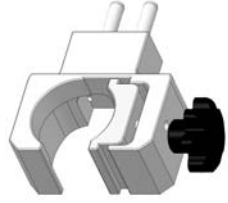

screwdriver adapter, part no. 101014A

Suitable for screwdriver style	Series	Screwdriver adapter, turnable - standard version, Part no.
EC screwdriver MINIMAT-EC, straight	320EGA27-..	367300E
	320EGA36-..	367300D
EC screwdriver MINIMAT-EC, pistol grip	320EPT27-..	367300A
	320EPT36-..	367300F

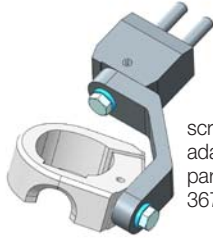

screwdriver adapter, part no. 367300D

Suitable for screwdriver style	Series	Screwdriver adapter, turnable - special version, Part no. for screwdrivers in conjunction with feeders only - in tight and badly accessible locations
EC screwdriver MINIMAT-EC, straight	320EGx27-..	401014B

## Screwdriver adapter for pneumatic screwdrivers

Suitable for screwdriver style	Motor size	Screwdriver adapter, not turnable - standard version, Part no.
NANOMAT, straight, push-to-start	00	400833Y
MINIMAT, straight, push-to-start	1	4008331A
	2 and 2.5	400833B
	3	400833A
MINIMAT, straight, lever-start	2 / 2.5 / 3	400833C
MINIMAT, straight, remote-start	4 with off-set gear	400833K (Linearstativ 408010C)
	4 without off-set gear	922644
MINIMAT, angle head design	2	400833W
	2.5	4008331N
	3	400833N
	4	400833L

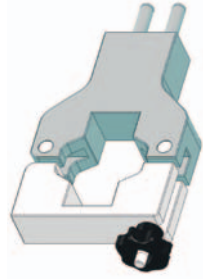

screwdriver adapter, part no. 400833C

Suitable for screwdriver style	Motor size	Screwdriver adapter, turnable - standard version, Part no.
MINIMAT, straight	2	367300E
MINIMAT, pistol grip	2	367300A
	2.5	367300B
	3	367300C

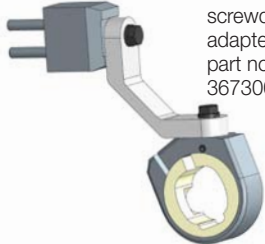

screwdriver adapter, part no. 367300E

Suitable for screwdriver style	Motor size	Screwdriver adapter, turnable - special version, Part no. for screwdrivers in conjunction with feeders only - in tight and badly accessible locations (please find picture on page 18)
MINIMAT	1	401014A
	2	401014B
	2.5	401014D
	3	401014C



Designation	Suitable for	Part no.	Picture
V-mounting bracket all-purpose applications	all tools upto a max torque of 1 Nm	4008331E	bracket range dia. 16.5-36 mm/0.64-1.4 in.
	all tools upto a max torque of 20 Nm	400833E	bracket range dia. 20 -54 mm/0.78-2.1 in.
	all tools upto a max torque of 40 Nm	4008331R	bracket range dia. 43 -64 mm/1.7 -2.5 in.
Adapter, turnable 45° and 90°	all screwdriver adapter (not for 400833K)	400833P	
Support ring	pneumatic screwdrivers, straight with push-to start (not for screwdrivers in conjunction with feeders) motor size 1 / motor size 2 / motor size 3	3870321 / 389775A / 398704A	
Pistol grip	MINIMAT-EC screwdriver, straight series 32OEGx27-.. series 32OEGx36-..	4055451E 4055452D	
	for pneumatic screwdrivers, straight, in conjunction with feeder motor size 1 (ERGOMAT, type 347V-..) motor size 1 (MINIMAT) motor size 2 (MINIMAT) motor size 2.5 (MINIMAT)	4055451A 4055451I 4055452B 4055451C	
Foam rubber grip	for pneumatic screwdrivers, straight (not suitable for ESD screwdriver, screwdriver in conjunction with feeder and screwdriver with lever-start) motor size 0 / motor size 1	833058 / 821702	
Handle	for pneumatic screwdrivers, straight motor size 1 (also in conjunction with feeder) motor size 2 motor size 2.5 motor size 2.5 in conjunction with feeder motor size 3	354660B 328536L 360749 3607491 328756A	
	for pneumatic screwdrivers, pistol grip motor size 2.5 (also in conjunction with feeder) motor size 3 (also in conjunction with feeder) motor size 4	3607493 4109711 4109711	

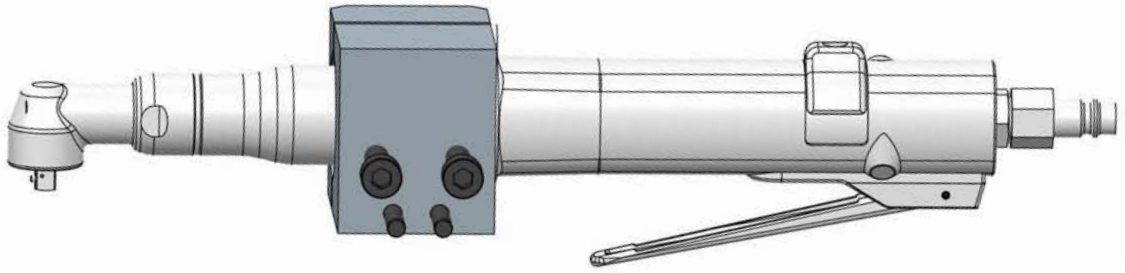

Screwdriver adapter, not turnable, standard version  
for screwdriver in angle head design,  
part no. 400833N/L

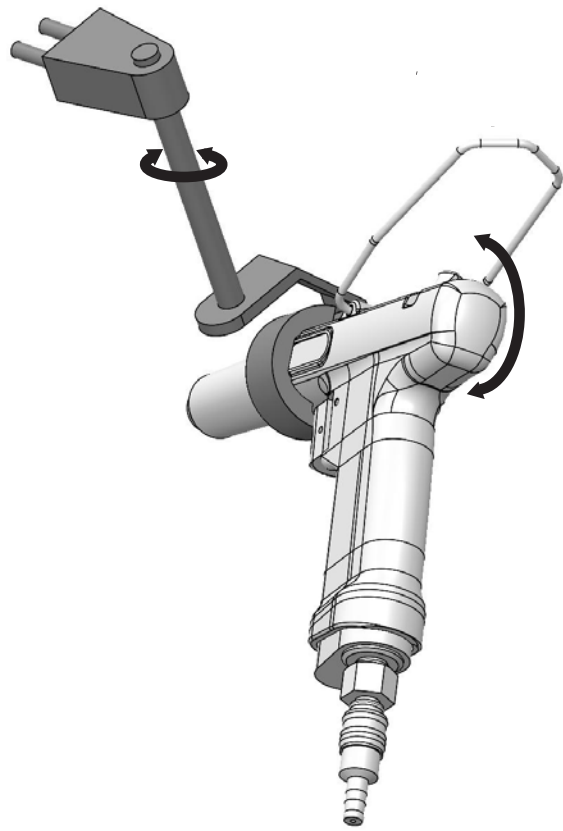

Screwdriver adapter, turnable,  
standard version for screwdriver in  
pistol grip design,  
part no. 367300A/B/C

Screwdriver adapter, turnable,  
standard version,  
part no. 367300D

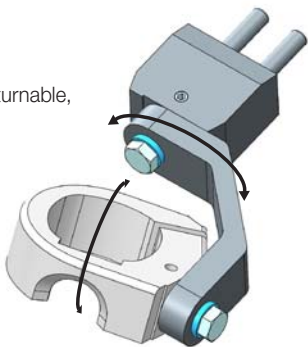

Screwdriver adapter, turnable,  
special version,  
part no. 401014A





# DEPRAG

**DEPRAG SCHULZ GMBH u. CO.**

P.O. Box 1352, D-92203 Amberg, Germany  
Carl-Schulz-Platz 1, D-92224 Amberg  
Phone (+49) 9621 371-0, Fax (+49) 9621 371-120  
[www.deprag.com](http://www.deprag.com)  
[info@deprag.de](mailto:info@deprag.de)

CERTIFIED AS PER DIN EN ISO 9001

---