



Screwdriving technology

Automation

Air motors

Air tools

DEPRAG

ADVANCED LINE

Stainless Steel Air Motors

from 20 W / 0.03 Hp up to 1.2 kW / 1.6 Hp

NEW MOTOR RANGE

High torque motors made from stainless steel:

Our ADVANCED LINE pneumatic motors are now available as high torque motors made from stainless steel. The ideal drive solution for e.g. agitators and industrial mixers.

non corrosive ATEX conform oil-free sealed
sterilisable compact insensitive to cleaning solvents

The ADVANCED LINE air motors are particularly suitable for use in the food industry, medical technology, underwater applications and the chemical industry.

Our air motors are also available in an ATEX conform complete system with integrated holding brakes.

All airmotors are made from stainless steel and can also be used without lubrication.

In addition our modular principle enables us to offer low cost customisations for your specific application!

All external parts (housing and spindle) of our ADVANCED LINE series are made from high quality non corrosive steel.



conform system: air motor - holding brake - gear



PRODUCT SPECTRUM OVERVIEW: ADVANCED LINE AIR MOTORS

Stainless steel motors with integrated planetary gears



The vane motors of the ADVANCED LINE are particularly compact drive solutions for installation in either handheld machines or industrial systems. These top quality stainless steel motors are suitable for the chemical industry, for the paper industry, the pharmaceutical industry, medical technology and also for use in the food industry.

Performance classes:

20 W	Page 4
30 W	Page 4
80 W	Page 6
120 W	Page 8
200 W	Page 10
300 W	Page 10
600 W	Page 16
900 W	Page 16
1.2 kW	Page 20

High torque stainless steel motors



The high torque motors of the ADVANCED LINE are small in size but provide extremely high output. Our high torque motors are also less apt to stall, the stalling torque for e.g. motor type 67-517 is 800 Nm / in.lbs. These drive solutions are particularly suitable for use in industrial agitators and mixers as used in the paint industry, food industry or pharmaceutical industry.

Performance classes:

285 W	Page 12
570 W	Page 18
860 W	Page 18

Stainless steel motors with integrated holding brake



Due to their size and design DEPRAG stainless steel motors with integrated holding brake are the optimal choice for use in any application where reliability plays an important role. The integrated holding brake can either be controlled using a separate control lead or via the motor exhaust. If pressure falls the brakes are automatically activated.

The big plus: This innovative complete system is also available with ATEX certification!

Performance classes:

200 W	Page 14
300 W	Page 14
1.2 kW	Page 22

ADVANTAGES OF ADVANCED LINE AIR MOTORS

LONG LIFE-SPAN

A wide product range of stainless steel motors, the use of DEPRAG high performance vanes as well as a specific surface coating on our materials all this ensures your motor's long life-span.



Airmotor - gear box - valve: a stainless steel system for the paper industry, sealed stainless steel motors, high performance vanes

SHORT DELIVERY TIMES

Due to our large amount of in-house production we are able to deliver quickly and flexibly at short notice, even when dealing with smaller quantities.

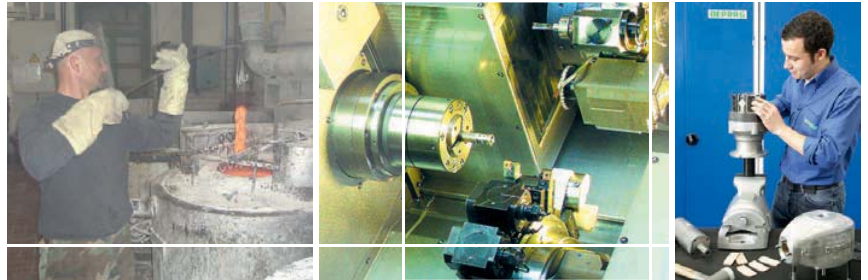

Large amount of in-house production, on-site salt bath heat treatment facility

APPLICATION CONSULTANCY

Our application engineers will gladly advise you in the selection of the most suitable drive for your application. If you would like to test or replace your existing drive we can check it for you in our innovative performance testing facility.



Performance testing facility, professional guidance from our engineers

WIDE VARIETY AND COMPREHENSIVE RANGE OF ACCESSORIES

Our standard programme is distinguished by its wide variety. All our stainless steel motors are also available with threaded spindle. Additionally due to our modular principle we are able to offer numerous variations to choose from. Do not hesitate to contact us if you have a specific mounting fixture request.

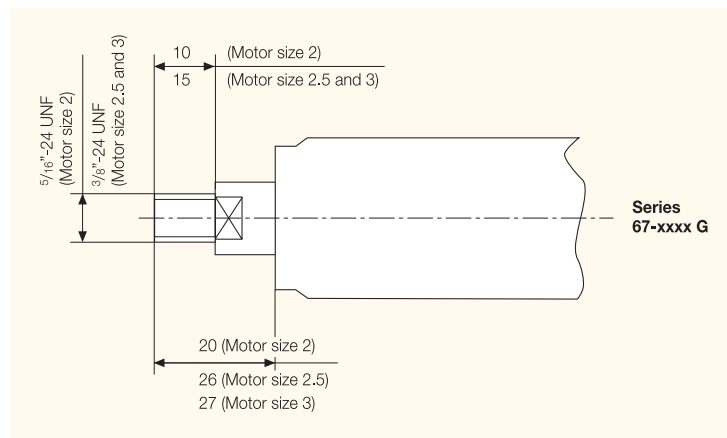

Individual customisation at an attractive price

20 W / 30 W ADVANCED LINE AIR MOTOR

Motor size 0		reversible			
Series 67-	Type	67-010	67-020	67-030	67-040
	Part no.	445115 B	445115 C	445115 D	445115 E
Nominal-Power	W / HP	20 / 0.03	20 / 0.03	20 / 0.03	20 / 0.03
Nominal-Speed	rpm	3000	2500	650	475
Speed (idling)	rpm	6000	5000	1300	950
Nominal-Torque	Nm / in.lbs	0.06 / 0.5	0.08 / 0.7	0.29 / 2.6	0.4 / 3.5
Start torque min.	Nm / in.lbs	0.09 / 0.8	0.12 / 1	0.44 / 3.9	0.6 / 5.3
Air consumption	m ³ /min / cfm	0.1 / 3	0.1 / 3	0.1 / 3	0.1 / 3
Weight	kg / lbs	0.16 / 0.3	0.16 / 0.3	0.16 / 0.3	0.16 / 0.3
Hose I.D.	mm / in.	3 / 1/8	3 / 1/8	3 / 1/8	3 / 1/8

Performance data relate to an air pressure of 6 bar (85 PSI) and lubricated air. With oil-free operation the output will be reduced by 10 - 20%.

Included in delivery: 2 Slide connectors (M 5)

Motor size 0		right rotation	
Series 67-	Type	67-010 R	67-040 R
	Part no.	445462 B	445462 E
Nominal-Power	W / HP	30 / 0.04	30 / 0.04
Nominal-Speed	rpm	3000	500
Speed (idling)	rpm	6000	1000
Nominal-Torque	Nm / in.lbs	0.08 / 0.7	0.57 / 5
Start torque min.	Nm / in.lbs	0.12 / 1	0.85 / 7.5
Air consumption	m ³ /min / cfm	0.1 / 3	0.1 / 3
Weight	kg / lbs	0.13 / 0.29	0.13 / 0.29
Hose I.D.	mm / in.	3 / 1/8	3 / 1/8

Performance data relate to an air pressure of 6 bar (85 PSI) and lubricated air. With oil-free operation the output will be reduced by 10 - 20%.

Included in delivery: 1 Slide connector (M 5)

Optional Equipment

for Motor size 0		reversible	right rotation
Flange	Part no.	445187	445187
necessary 3 cylinder-screws	Part no.	828955	828955
1 Silencer (M 5)	Part no.	811355	-
Maintenance unit with lubricator*	Part no.	820454 A	820454 A
Connection thread		G 1/4	G 1/4
Maintenance unit without lubricator*	Part no.	822408 A	822408 A
Connection thread		G 1/4	G 1/4
Replacement part set consisting of: vanes, sealant rings, o-rings and silencers	Part no.	446083 B	446083 B

*) Maintenance unit consists of pressure regulator valve, filter and optionally with or without lubricator

Of course you can also purchase individual replacement parts from us.

Allowable shaft loading see page 24.

Further notes for soundproofing see page 25.

80 W ADVANCED LINE AIR MOTOR

Motor size 1		reversible				
Series 67-	Type	67-001	67-011	67-021	67-031	67-081
	Part no.	445127 A	445127 B	445127 C	445127 D	445127 E
Nominal-Power	W / HP	80 / 0.11	80 / 0.11	80 / 0.11	80 / 0.11	80 / 0.11
Nominal-Speed	rpm	11000	3500	950	650	120
Speed (idling)	rpm	22000	7000	1900	1300	240
Nominal-Torque	Nm / in.lbs	0.06 / 0.5	0.22 / 1.9	0.8 / 7	1.2 / 11	2 / 17.7 *)
Start torque min.	Nm / in.lbs	0.09 / 0.8	0.33 / 2.9	1.2 / 11	1.8 / 16	2 / 17.7 *)
Air consumption	m ³ /min / cfm	0.23 / 8	0.23 / 8	0.23 / 8	0.23 / 8	0.23 / 8
Length L	mm / in.	96.5 / 3.76	96.5 / 3.76	105.5 / 4.1	105.5 / 4.1	113.5 / 4.4
Weight	kg / lbs	0.2 / 0.4	0.2 / 0.4	0.22 / 0.5	0.22 / 0.5	0.29 / 0.6
Hose I.D.	mm / in.	4 / ⁵ / ₃₂	4 / ⁵ / ₃₂	4 / ⁵ / ₃₂	4 / ⁵ / ₃₂	4 / ⁵ / ₃₂

Performance data relate to an air pressure of 6 bar (85 PSI) and lubricated air. With oil-free operation the output will be reduced by 10 - 20%.

*) max. admissible torque

Optional Equipment

for Motor size 1		
Flange	Part no.	445181
necessary 3 cylinder-screws	Part no.	831728
Bracket	Part no.	445180
necessary 3 cylinder-screws	Part no.	831728
3 Slide connectors (M8 x 0.75)	Part no.	included in delivery
2 Silencer	Part no.	823236
necessary 2 Slide connectors	Part no.	824838
1 Hose 0.2 m	Part no.	822283
Maintenance unit with lubricator*	Part no.	820454 A
Connection thread		G 1/4
Maintenance unit without lubricator*	Part no.	822408 A
Connection thread		G 1/4
Replacement part set consisting of: vanes, sealant rings, o-rings and silencers	Part no.	446084 B

*) Maintenance unit consists of pressure regulator valve, filter and optionally with or without lubricator

Of course you can also purchase individual replacement parts from us.

Allowable shaft loading see page 24.

Further notes for soundproofing see page 25.

Motor size 1
Series 67-
 reversible

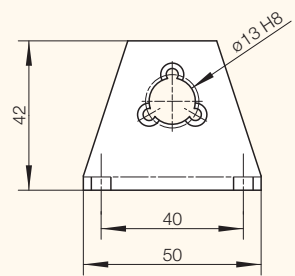
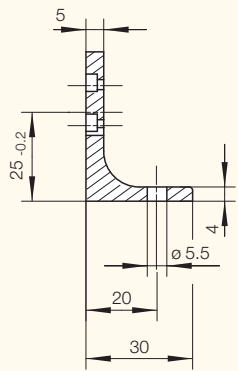
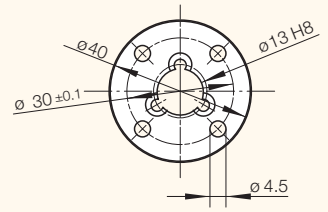
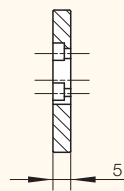
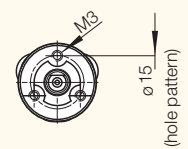
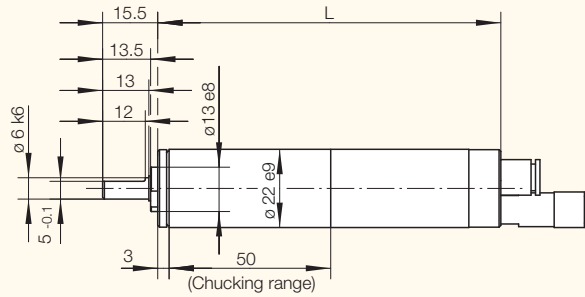
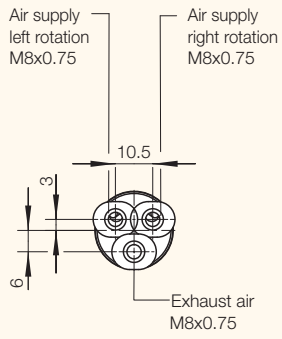

Dimensions in mm

p4400602

120 W ADVANCED LINE AIR MOTOR

Motor size 2			reversible						
Series 67- 	Type Part no.	67-002	67-012	67-022	67-032	67-042	67-052	67-2521	
Nominal-Power	W / HP	120 / 0.16	120 / 0.16	120 / 0.16	120 / 0.16	120 / 0.16	120 / 0.16	90 / 0.12 ¹⁾	
Nominal-Speed	rpm	11000	2750	1800	700	450	300	50 ¹⁾	
Speed (idling)	rpm	22000	5500	3600	1400	900	600	100	
Nominal-Torque	Nm / in.lbs	0.10 / 0.9	0.4 / 3.5	0.6 / 5.3	1.6 / 14	2.5 / 22	3.8 / 34	5 / 44 ^{*)}	
Start torque min.	Nm / in.lbs	0.15 / 1.3	0.6 / 5.3	0.9 / 8	2.4 / 21	3.8 / 34	5 / 44 ^{*)}	5 / 44 ^{*)}	
Air consumption	m ³ /min / cfm	0.3 / 11	0.3 / 11	0.3 / 11	0.3 / 11	0.3 / 11	0.3 / 11	0.3 / 11	
Weight	kg / lbs	0.35 / 0.8	0.35 / 0.8	0.35 / 0.8	0.4 / 0.9	0.4 / 0.9	0.4 / 0.9	0.45 / 1	
Hose I.D.	mm / in.	6 / ¼	6 / ¼	6 / ¼	6 / ¼	6 / ¼	6 / ¼	6 / ¼	

Performance data relate to an air pressure of 6 bar (85 PSI) and lubricated air. With oil-free operation the output will be reduced by 10 - 20%.

^{*)} max. admissible torque

¹⁾ theoretical values for issuing the power diagram

Optional Equipment

for Motor size 2		
Flange	Part no.	444569
necessary 4 cylinder-screws	Part no.	823216
Bracket	Part no.	444572
necessary 4 cylinder-screws	Part no.	823216
Silencer: motor operates in one direction (right or left rotation)		
1 Hose nozzle	Part no.	823237
2 Silencer	Part no.	823236
Silencer: motor is reversible (right and left rotation)		
2 Hose nozzles	Part no.	823237
1 Silencer	Part no.	823236
Maintenance unit with lubricator*	Part no.	820454 A
Connection thread		G 1/4
Maintenance unit without lubricator*	Part no.	822408 A
Connection thread		G 1/4
Replacement part set consisting of: vanes, sealant rings, o-rings and silencers	Part no.	445580 A

^{*)} Maintenance unit consists of pressure regulator valve, filter and optionally with or without lubricator

Of course you can also purchase individual replacement parts from us. Our standard maintenance units are ATEX conform. Please contact us if this is a requirement.

Allowable shaft loading see page 24.

Further notes for soundproofing see page 25.

Motor size 2
Series 67-
 reversible

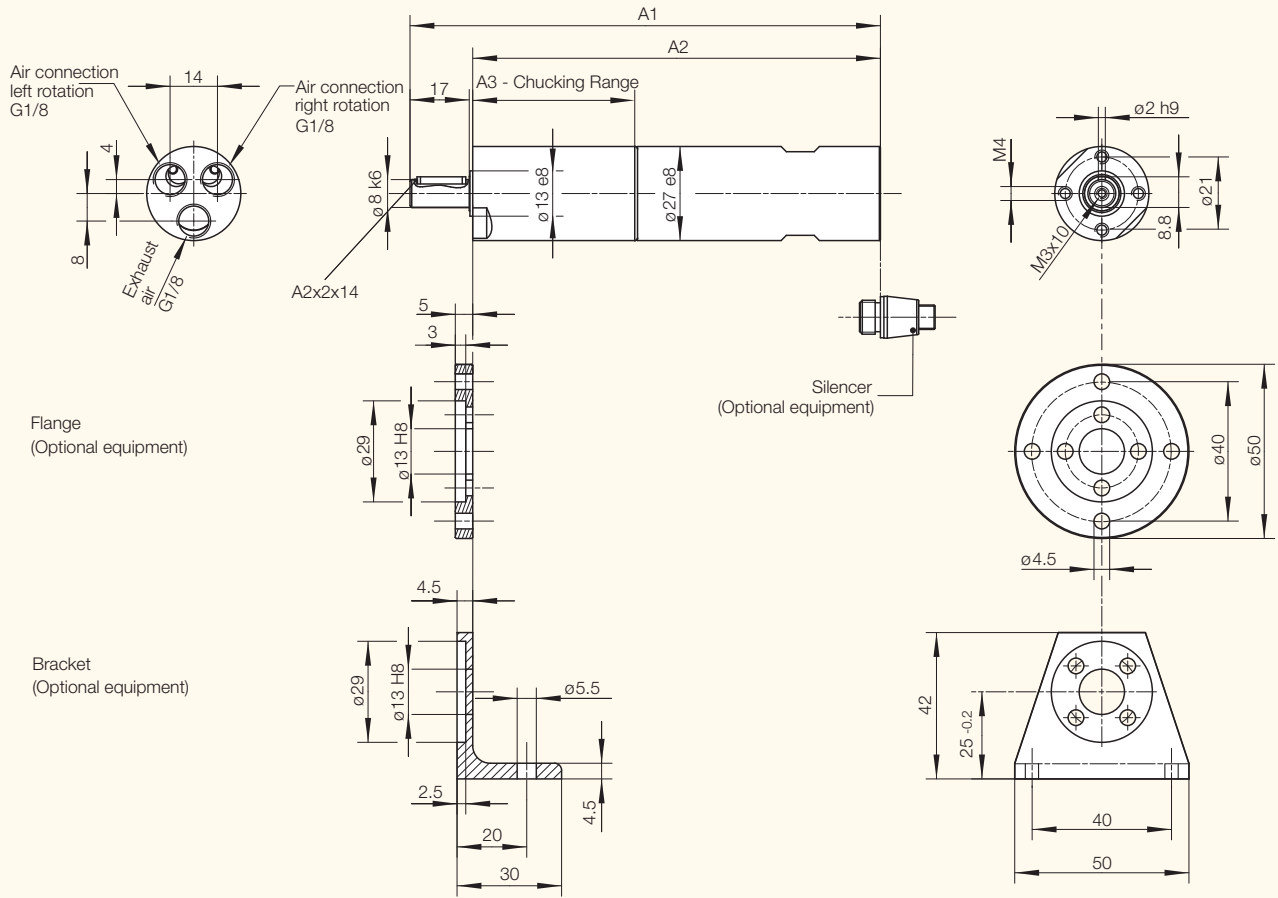

Dimensions in mm

p4402205

Motor size	Series 67- Type			Dimensions of motor (mm)		
				A1	A2	A3
2	67-002	67-012	67-022	135	117	46.5
	67-032	67-042	67-052	147.5	129.5	59
	67-2521			160	142	71.5

200 W / 300 W ADVANCED LINE DRUCKLUFTMOTOR

Motor size 2.5		reversible								
Series 67-  II 2 GD c IIC T6 (80°C)	Type Part no.	67-0025	67-0125	67-0225	67-0725	67-0325	67-0425	67-04251	67-24251	
Nominal-Power	W / HP	200 / 0.27	200 / 0.27	200 / 0.27	200 / 0.27	200 / 0.27	200 / 0.27	100 / 0.13	180 / 0.24 ¹⁾	
Nominal-Speed	rpm	7250	2300	1200	700	350	160	90	25 ¹⁾	
Speed (idling)	rpm	14500	4600	2400	1400	700	320	180	50	
Nominal-Torque	Nm / in.lbs	0.26 / 2.3	0.8 / 7.1	1.6 / 14	2.7 / 24	5.4 / 48	12 / 106	10.5 / 93	20 / 177 ^{*)}	
Start torque min.	Nm / in.lbs	0.4 / 3.5	1.2 / 11	2.4 / 21	4.1 / 36	8.2 / 73	18 / 159	15 / 133	20 / 177 ^{*)}	
Air consumption	m ³ /min / cfm	0.37 / 13	0.37 / 13	0.37 / 13	0.37 / 13	0.37 / 13	0.37 / 13	0.27 / 9	0.37 / 13	
Weight	kg / lbs	0.7 / 1.5	0.75 / 1.6	0.75 / 1.6	0.85 / 1.9	0.85 / 1.9	0.85 / 1.9	0.85 / 1.9	0.95 / 2.1	
Hose I.D.	mm / in.	10 / 3/8	10 / 3/8	10 / 3/8	10 / 3/8	10 / 3/8	10 / 3/8	10 / 3/8	10 / 3/8	

Performance data relate to an air pressure of 6 bar (85 PSI) and lubricated air. With oil-free operation the output will be reduced by 10 - 20%.

^{*)} max. admissible torque

¹⁾ theoretical values for issuing the power diagram

Motor size 3		reversible								
Series 67-  II 2 GD c IIC T6 (80°C)	Type Part no.	67-003	67-013	67-023	67-073	67-083	67-093	67-0931	67-1931	67-2931
Nominal-Power	W / HP	300 / 0.4	300 / 0.4	300 / 0.4	300 / 0.4	300 / 0.4	300 / 0.4	130 / 0.17	280/0.37 ¹⁾	280/0.37 ¹⁾
Nominal-Speed	rpm	7250	2300	1200	700	300	170	90	50	25 ¹⁾
Speed (idling)	rpm	14500	4600	2400	1400	600	340	180	100	50
Nominal-Torque	Nm / in.lbs	0.4 / 3.5	1.2 / 11	2.4 / 21	4.1 / 36	9.6 / 85	16.9 / 149	13.8 / 122	36 / 319 ^{*)}	36 / 319 ^{*)}
Start torque min.	Nm / in.lbs	0.6 / 5.3	1.9 / 17	3.6 / 32	6.1 / 54	14.3 / 126	25.3 / 224	21 / 186	36 / 319 ^{*)}	36 / 319 ^{*)}
Air consumption	m ³ /min / cfm	0.47 / 17	0.47 / 17	0.47 / 17	0.47 / 17	0.47 / 17	0.47 / 17	0.28 / 10	0.47 / 17	0.47 / 17
Weight	kg / lbs	1.0 / 2.2	1.05 / 2.3	1.05 / 2.3	1.10 / 2.4	1.15 / 2.5	1.15 / 2.5	1.15 / 2.5	1.25 / 2.7	1.25 / 2.7
Hose I.D.	mm / in.	10 / 3/8	10 / 3/8	10 / 3/8	10 / 3/8	10 / 3/8	10 / 3/8	10 / 3/8	10 / 3/8	10 / 3/8

Performance data relate to an air pressure of 6 bar (85 PSI) and lubricated air. With oil-free operation the output will be reduced by 10 - 20%.

^{*)} max. admissible torque

¹⁾ theoretical values for issuing the power diagram

Optional Equipment

		for Motor size 2.5	for Motor size 3
Flange	Part no.	444530	444610
necessary 4 cylinder-screws	Part no.	823216	823139
Bracket	Part no.	444539	444611
necessary 4 cylinder-screws	Part no.	823216	823139
Silencer: motor operates in one direction (right or left rotation)			
1 Hose nozzle	Part no.	823238 (1/8")	410541 (1/4")
1 Silencer	Part no.	802675 (1/8")	802673 (1/4")
1 Silencer	Part no.	802673 (1/4")	802673 (1/4")
Silencer: motor is reversible (right or left rotation)			
2 Hose nozzles	Part no.	823238 (1/8")	410541 (1/4")
1 Silencer	Part no.	802673 (1/4")	802673 (1/4")
Maintenance unit with lubricator*	Part no.	820454 A	820455 A
Connection thread		G 1/4	G 1/2
Maintenance unit without lubricator*	Part no.	822408 A	822409 A
Connection thread		G 1/4	G 1/2
Replacement part set consisting of: vanes, sealant rings, o-rings and silencers	Part no.	444785 A	444786 A

^{*)} Maintenance unit consists of pressure regulator valve, filter and optionally with or without lubricator

Of course you can also purchase individual replacement parts from us. Our standard maintenance units are ATEX conform. Please contact us if this is a requirement.

Allowable shaft loading see page 24.

Further notes for soundproofing see page 25.

Motor size 2.5 and Motor size 3

Series 67-

reversible

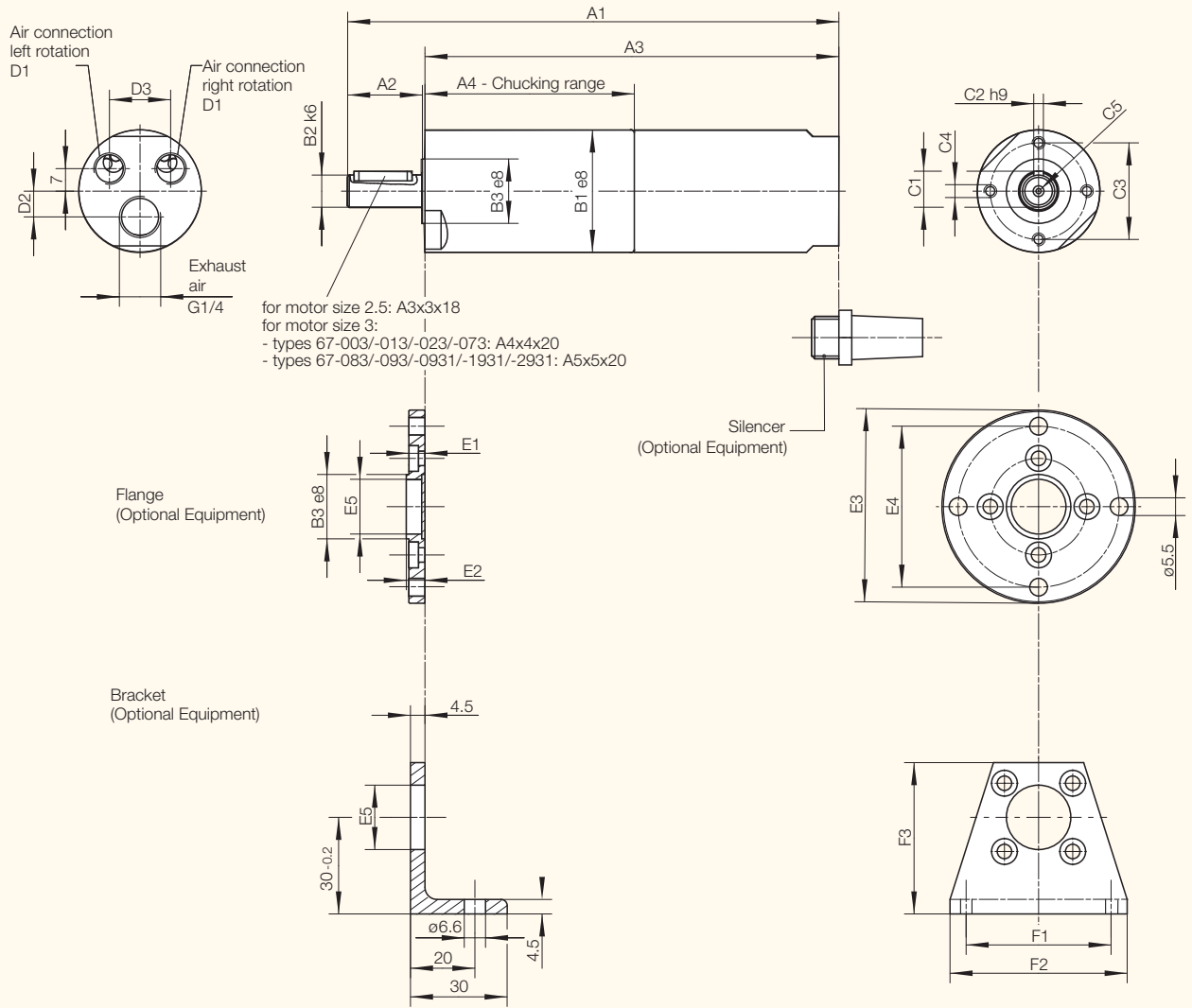

Dimensions in mm

p4402777

Motor size	Series 67- Type				Dimensions of motor (mm)														
					A1	A2	A3	A4	B1	B2	B3	C1	C2	C3	C4	C5	D1	D2	D3
2.5	67-0025	67-0125	67-0225		151		127	64											
	67-0725	67-0325	67-0425	67-04251	167	23	143	80	38	10	20	11.2	3	30	M4	1.6	G1/8	8	19
	67-24251				183		159	96											
3	67-003	67-013	67-023		171		143	66											
	67-073				187	27				12		13.5	4			M4x12			
	67-083	67-093	67-0931		191	30	159	82	42	24				34	M5		G1/4	11	20
	67-1931	67-2931			196	31	164					16	5			M5x12			

Motor size	Series 67- Type				Dimensions of flange (mm)					Dimensions of bracket (mm)									
					B3	E1	E2	E3	E4	E5	F1	F2	F3						
2.5	67-0025	67-0125	67-0225																
	67-0725	67-0325	67-0425	67-04251	20	5	5.8	60	50	17		45	55	47					
	67-24251																		
3	67-003	67-013	67-023																
	67-073																		
	67-083	67-093	67-0931		24	6	6.8	65	55	21		50	60	48					
	67-1931	67-2931																	

285 W ADVANCED LINE HIGH TORQUE MOTOR

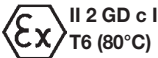
Motor size 3 with high torque		reversible				
Series 67-  II 2 GD c IIC T6 (80°C)	Type	67-313	67-323	67-373	67-413	67-423
	Part no.	444560 I	444560 L	444560 M	444560 N	444560 O
Nominal-Power	W / HP	285 / 0.38	285 / 0.38	280 / 0.37	280 / 0.37	280 / 0.37
Nominal-Speed	rpm	85	40	25	13	7
Speed (idling)	rpm	170	80	50	26	14
Nominal-Torque	Nm / in.lbs	32 / 283.2	62 / 548.7	110 / 973.5	210 / 1858.5	410 / 3628.5
Start torque min.	Nm / in.lbs	47 / 416	92 / 814	162 / 1433.7	320 / 2832	615 / 5442.8
Air consumption	m ³ /min / cfm	0.47 / 16.6	0.47 / 16.6	0.47 / 16.6	0.47 / 16.6	0.47 / 16.6
Weight	kg / lbs	2.7 / 5.9	2.6 / 5.7	2.9 / 6.4	3.5 / 7.7	3.5 / 7.7
Hose I.D.	mm / in.	10 / ³ / ₈	10 / ³ / ₈	10 / ³ / ₈	10 / ³ / ₈	10 / ³ / ₈

Performance data relate to an air pressure of 6 bar (85 PSI) and lubricated air. With oil-free operation the output will be reduced by 10 - 20%.

Optional Equipment

		for Motor size 3 Type 67-313 to 67-373	for Motor size 3 Type 67-413 to 67-423
Flange	Part no.	413462	413463
necessary cylinder-screws	Part no.	823148 (8 pieces)**	823545 (6 pieces)**
Bracket	Part no.	4446172	4446173
necessary cylinder-screws	Part no.	823148 (8 pieces)**	823545 (6 pieces)**
Silencer: motor operates in one direction (right or left rotation)			
1 Hose nozzle	Part no.	410541 (1/4")	410541 (1/4")
2 Silencer	Part no.	802673 (1/4")	802673 (1/4")
Silencer: motor is reversible (right or left rotation)			
2 Hose nozzles	Part no.	410541 (1/4")	410541 (1/4")
1 Silencer	Part no.	802673 (1/4")	802673 (1/4")
Maintenance unit with lubricator*	Part no.	820455 A	820455 A
Connection thread		G 1/2	G 1/2
Maintenance unit without lubricator*	Part no.	822409 A	822409 A
Connection thread		G 1/2	G 1/2
Replacement part set consisting of: vanes, sealant rings, o-rings and silencers	Part no.	444786 B	444786 C

*) Maintenance unit consists of pressure regulator valve, filter and optionally with or without lubricator

***) no. of cylinder screws required

Of course you can also purchase individual replacement parts from us. Our standard maintenance units are ATEX conform. Please contact us if this is a requirement.

Allowable shaft loading see page 24.

Further notes for soundproofing see page 25.

Motor size 3 High torque stainless steel motors**Series 67-**

reversible

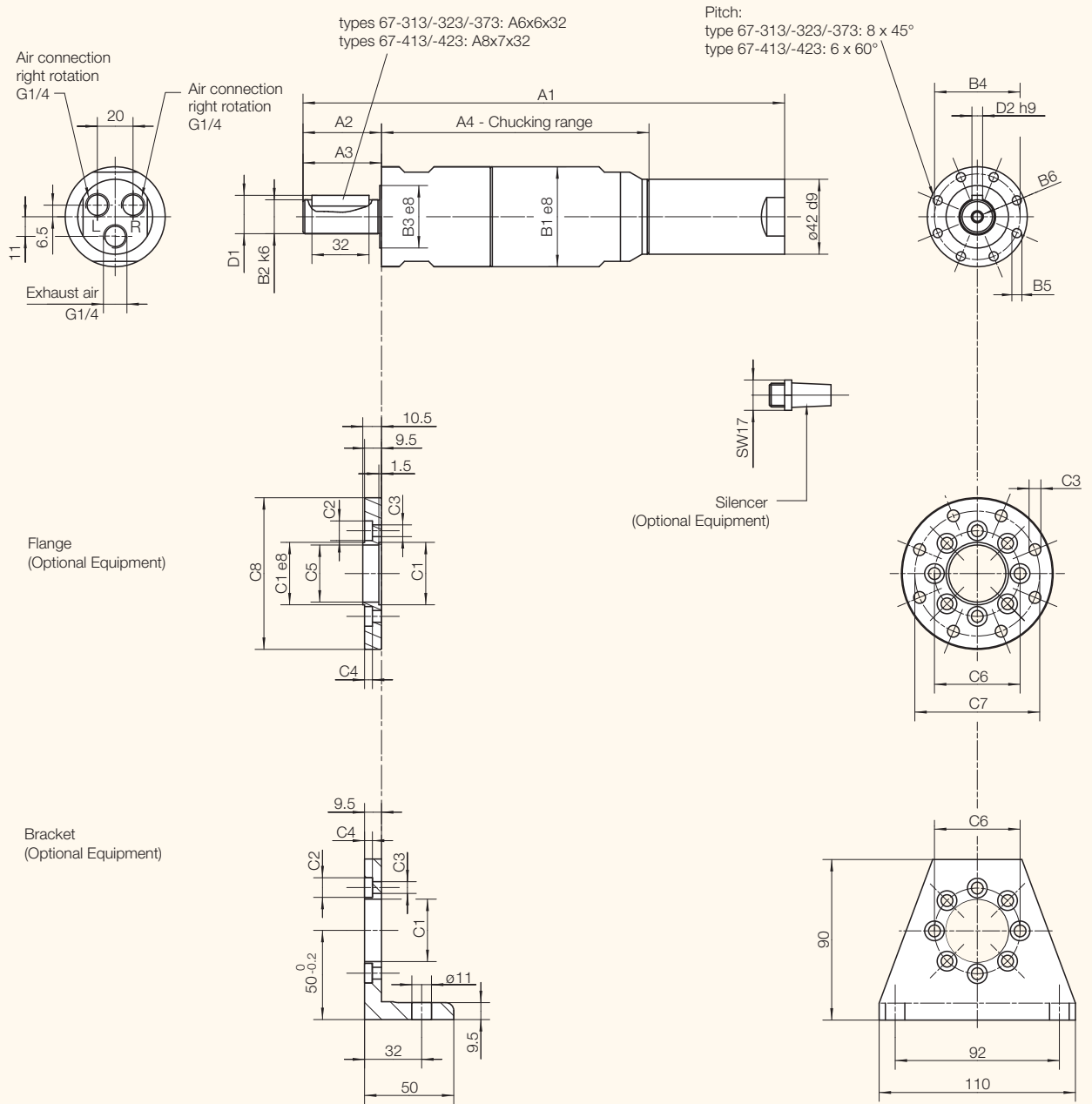

p444204

Motor size	Series 67- Type		Dimensions of motor (mm)																			
			A1	A2	A3	A4	B1	B2	B3	B4	B5	B6	C1	C2	C3	C4	C5	C6	C7	C8	D1	D2
3	67-313	67-323	254.1	44	42	133.1	56	19	35	48	M6	M6x12	35	11	6.6	4	32	48	70	85	21.5	6
	67-373		269.9			148.9																
	67-413	67-423	279.2	47	45	155.2	63	24	34	45	M8	M8x19	34	13	8.4	5	30	45	79	95	27	8

200 W / 300 W ADVANCED LINE AIR MOTOR WITH INTEGRATED HOLDING BRAKE

Motor size 2.5 with holding brake			reversible				
Series 67- ATEX konform II 2 GD c IIC T6 (80°C)	Type Part no.	67-0025 B 4457602B	67-0125 B 4457602C	67-0225 B 4457602D	67-0725 B 4457602F	67-0325 B 4457602E	67-0425 B 4457602A
Series 67-	Type Part no.	67-0025 B 445760 B	67-0125 B 445760 C	67-0225 B 445760 D	67-0725 B 445760 F	67-0325 B 445760 E	67-0425 B 445760 A
Nominal-Power	W / HP	200 / 0.27	200 / 0.27	200 / 0.27	200 / 0.27	200 / 0.27	200 / 0.27
Nominal-Speed	rpm	7250	2300	1200	700	350	160
Speed (idling)	rpm	14500	4600	2400	1400	700	320
Nominal-Torque	Nm / in.lbs	0.26 / 2.3	0.8 / 7.1	1.6 / 14	2.7 / 24	5.4 / 48	12 / 106
Start torque min.	Nm / in.lbs	0.4 / 3.5	1.2 / 11	2.4 / 21	4.1 / 36	8.2 / 73	18 / 159
Brake-Torque	Nm / in.lbs	0.52 / 4.6	1.6 / 14.2	3.2 / 28	5.4 / 48	10.8 / 96	20 / 177*)
Brems-Drehmoment	Nm / in.lbs	1 / 9	3.4 / 30	6.7 / 59	11.8 / 104	20 / 177*)	20 / 177*)
Air consumption	m³/min / cfm	0.37 / 13	0.37 / 13	0.37 / 13	0.37 / 13	0.37 / 13	0.37 / 13
Weight	kg / lbs	1 / 2.2	1.05 / 2.3	1.05 / 2.3	1.15 / 2.5	1.15 / 2.5	1.15 / 2.5
Hose I.D.	mm / in.	10 / 3/8	10 / 3/8	10 / 3/8	10 / 3/8	10 / 3/8	10 / 3/8
Motor size 3 with holding brake			reversible				
Series 67- ATEX konform II 2 GD c IIC T6 (80°C)	Type Part no.	67-003 B 457622A	67-013 B 4457622B	67-023 B 4457622C	67-073 B 4457622D	67-083 B 4457622E	67-093 B 4457622F
Series 67-	Type Part no.	67-003 B 445762 A	67-013 B 445762 B	67-023 B 445762 C	67-073 B 445762 D	67-083 B 445762 E	67-093 B 445762 F
Nominal-Power	W / HP	300 / 0.4	300 / 0.4	300 / 0.4	300 / 0.4	300 / 0.4	300 / 0.4
Nominal-Speed	rpm	7250	2300	1200	700	300	170
Speed (idling)	rpm	14500	4600	2400	1400	600	340
Nominal-Torque	Nm / in.lbs	0.4 / 3.5	1.2 / 11	2.4 / 21	4.1 / 36	9.6 / 85	16.9 / 149
Start torque min.	Nm / in.lbs	0.6 / 5.3	1.9 / 17	3.6 / 32	6.1 / 54	14.3 / 126	25.3 / 224
Brake-Torque	Nm / in.lbs	0.8 / 7	2.4 / 21	4.8 / 42	8.2 / 72	19.2 / 170	33.8 / 299
Brems-Drehmoment	Nm / in.lbs	1 / 9	3.4 / 30	6.7 / 59	11.8 / 104	20.6 / 182	36 / 318.6*)
Air consumption	m³/min / cfm	0.47 / 17	0.47 / 17	0.47 / 17	0.47 / 17	0.47 / 17	0.47 / 17
Weight	kg / lbs	1.35 / 3	1.4 / 3.1	1.4 / 3.1	1.45 / 3.2	1.5 / 3.3	1.5 / 3.3
Hose I.D.	mm / in.	10 / 3/8	10 / 3/8	10 / 3/8	10 / 3/8	10 / 3/8	10 / 3/8

Performance data relate to an air pressure of 6 bar (85 PSI) and lubricated air. With oil-free operation the output will be reduced by 10 - 20%.

*) max. admissible torque

Optional Equipment:	for Motor size 2.5	for Motor size 3	
Flange	Part no.	444530	444610
necessary 4 cylinder-screws	Part no.	823216	823139
Bracket	Part no.	444539	444611
necessary 4 cylinder-screws	Part no.	823216	823139
Silencer: motor operates in one direction (right or left rotation)			
1 Hose nozzle	Part no.	823238 (1/8")	410541 (1/4")
1 Silencer	Part no.	802675 (1/8")	802673 (1/4")
1 Silencer	Part no.	802673 (1/4")	802673 (1/4")
Silencer: Motor is reversible (right or left rotation)			
2 Hose nozzles	Part no.	823238 (1/8")	410541 (1/4")
1 Silencer	Part no.	802673 (1/4")	802673 (1/4")
Maintenance unit with lubricator*	Part no.	820454 A	820455 A
Connection thread		G 1/4	G 1/2
Maintenance unit without lubricator*	Part no.	822408 A	822409 A
Connection thread		G 1/4	G 1/2
Replacement part set consisting of: vanes, sealant rings, o-rings and silencers	Part no.	444785 A	444786 A
Replacement part set for brake consisting of: discs, pressure spring and o-rings	Part no.	446096 C	446096 C

*) Maintenance unit consists of pressure regulator valve, filter and optionally with or without lubricator

<p>Of course you can also purchase individual replacement parts from us.</p> <p>Our standard maintenance units are ATEX conform. Please contact us if this is a requirement.</p>	<p>Allowable shaft loading see page 24.</p>	<p>Further notes for sound-proofing see page 25.</p>	<p>A pressure regulator valve is included within our shipment of the ATEX conform brake motors. This safety valve turns off the air supply in the brake leads automatically when the pressure falls under 5 bar. This prevents an irregular temperatur increase.</p>
--	---	--	--

Motor size 2.5 and Motor size 3 with holding break

Series 67-

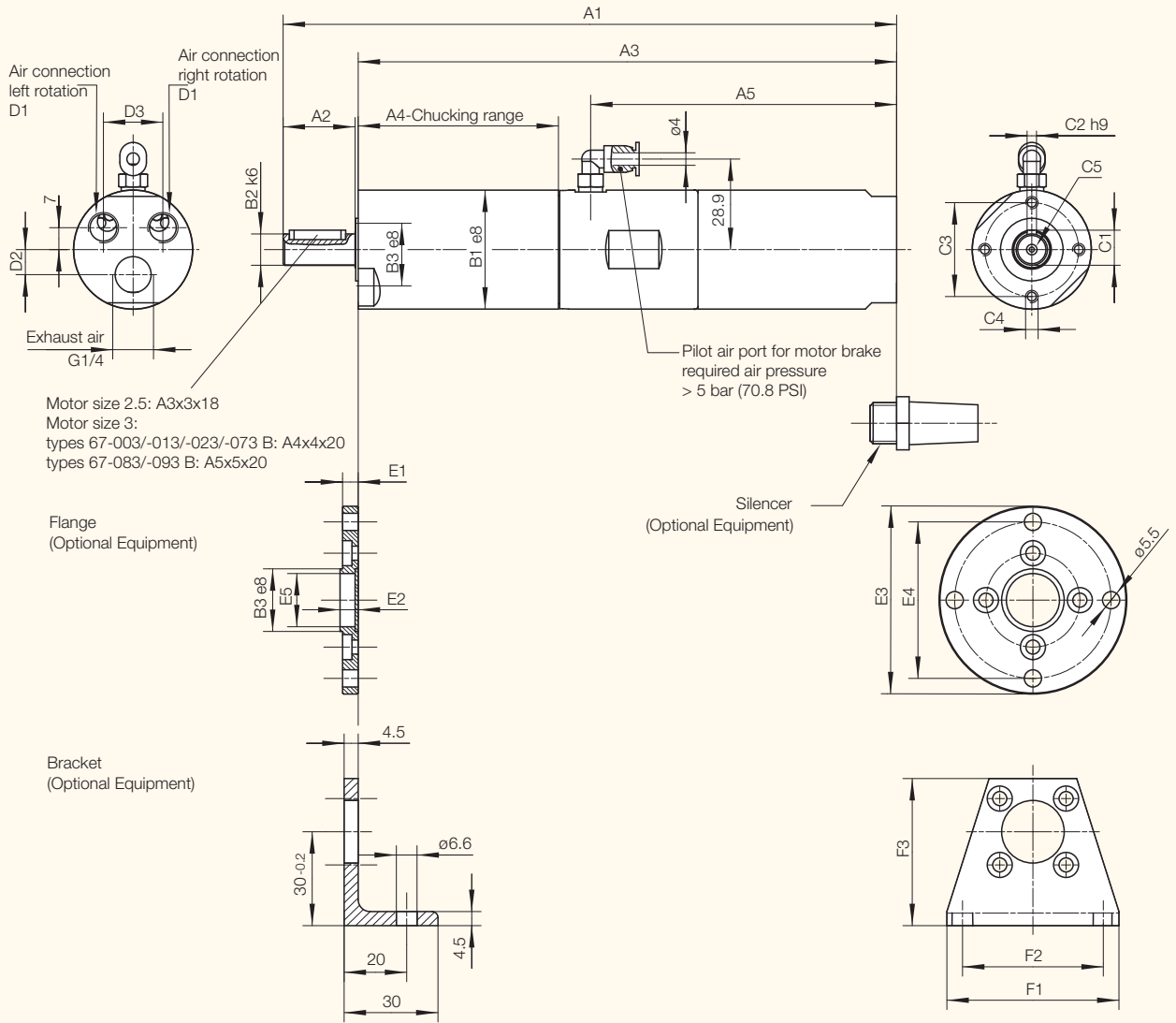

reversible



Motor size	Series 67- Type			Dimensions of motor (mm)																				
				A1	A2	A3	A4	A5	B1	B2	B3	C1	C2	C3	C4	C5	D1	D2	D3					
2.5	67-0025 B	67-0125 B	67-0225 B	194		170	64																	
	67-0725 B	67-0325 B	67-0425 B	210	23	186	80	98	38	10	20	11.2	3	30	M4	1.6	G1/8	8	19					
3	67-003 B	67-013 B	67-023 B	215		187	66																	
	67-073 B			231	27		82	110	42	12	24	13.5	4	34	M5	M4x12	G1/4	11	20					
	67-083 B	67-093 B		235	30	203				14		16	5			M5x12								

Motor size	Series 67- Type			Dimensions of flange (mm)					Dimensions of bracket (mm)															
				B3	E1	E2	E3	E4	E5	F1	F2	F3												
2.5	67-0025 B	67-0125 B	67-0225 B																					
	67-0725 B	67-0325 B	67-0425 B	20	5	5.8	60	50	17	55	45	47												
3	67-003 B	67-013 B	67-023 B																					
	67-073 B																							
	67-083 B	67-093 B		24	6	6.8	65	55	21	60	50	48												

600 W / 900 W ADVANCED LINE AIR MOTOR

Motor size 6			reversible							
Series 67-	 II 2 GD c IIC T6 (80°C)	Type Part no.	67-006 444570 A	67-016 444570 H	67-026 444570 B	67-036 444570 C	67-046 444570 D	67-056 444570 E	67-066 444570 F	67-0661 444570 G
Series 67- for Drill-Chuck		Type Part no.	–	67-016B16 445353 H	67-026B16 445353 B	67-036B16 445353 C	67-046B16 445353 D	67-056B16 445353 E	67-066B16 445353 F	67-0661B16 445353 G
Nominal-Power	W / HP		600 / 0.8	600 / 0.8	600 / 0.8	600 / 0.8	600 / 0.8	600 / 0.8	600 / 0.8	300 / 0.4
Nominal-Speed	rpm		7000	1750	1350	850	315	240	150	75
Speed (idling)	rpm		14000	3500	2700	1700	630	480	300	150
Nominal-Torque	Nm / in.lbs		0.82 / 7	3.2 / 28	4.2 / 37	6.7 / 59	18 / 159	24 / 212	38 / 336	38 / 336
Start torque min.	Nm / in.lbs		1.23 / 11	4.8 / 42	6.4 / 57	10.1 / 89	27 / 239	36 / 319	57 / 504	57 / 504
Air consumption	m ³ /min / cfm		0.85 / 30	0.85 / 30	0.85 / 30	0.85 / 30	0.85 / 30	0.85 / 30	0.85 / 30	0.55 / 19
Weight	kg / lbs		2.2 / 4.8	2.3 / 5	2.3 / 5	2.3 / 5	2.6 / 5.7	2.7 / 5.9	2.7 / 5.9	2.7 / 5.9
Hose I.D.	mm / in.		12 / 1/2	12 / 1/2	12 / 1/2	12 / 1/2	12 / 1/2	12 / 1/2	12 / 1/2	12 / 1/2
Motor size 7			reversible							
Series 67-	 II 2 GD c IIC T6 (80°C)	Type Part no.		67-007 440066 A	67-017 440066 H	67-027 440066 B	67-037 440066 C	67-047 440066 D	67-057 440066 E	67-067 440066 F
Nominal-Power	W / HP			900 / 1.2	900 / 1.2	900 / 1.2	900 / 1.2	900 / 1.2	900 / 1.2	900 / 1.2
Nominal-Speed	rpm			6000	1750	1350	850	315	240	150
Speed (idling)	rpm			12000	3500	2700	1700	630	480	300
Nominal-Torque	Nm / in.lbs			1.4 / 12.4	4.9 / 43.4	6.3 / 55.7	10.1 / 89.4	27 / 238.9	35 / 309.7	57 / 504.5
Start torque min.	Nm / in.lbs			2.1 / 18.6	7.3 / 64.6	9.5 / 84.1	15.2 / 134.5	40 / 354	53 / 469	85 / 752
Air consumption	m ³ /min / cfm			1.4 / 49.4	1.4 / 49.4	1.4 / 49.4	1.4 / 49.4	1.4 / 49.4	1.4 / 49.4	1.4 / 49.4
Weight	kg / lbs			2.5 / 5.5	2.6 / 5.7	2.6 / 5.7	2.6 / 5.7	2.9 / 6.4	3 / 6.6	3 / 6.6
Hose I.D.	mm / in.			12 / 1/2	12 / 1/2	12 / 1/2	12 / 1/2	12 / 1/2	12 / 1/2	12 / 1/2

Performance data relate to an air pressure of 6 bar (85 PSI) and lubricated air. With oil-free operation the output will be reduced by 10 - 20%.

Optional Equipment:		for Motor size 6	for Motor size 7
Flange	Part no.	444616	444616
necessary 4 cylinder-screws	Part no.	823148	823148
Bracket	Part no.	444617	444617
necessary 4 cylinder-screws	Part no.	823148	823148
Silencer: motor operates in one direction (right or left rotation)			
1 Hose nozzle	Part no.	410540 (3/8")	410540 (3/8")
1 Silencer	Part no.	802671 (3/8")	802671 (3/8")
1 Silencer	Part no.	802666 (1/2")	802666 (1/2")
Silencer: Motor is reversible (right or left rotation)			
2 Hose nozzles	Part no.	410540 (3/8")	410540 (3/8")
1 Silencer	Part no.	802666 (1/2")	802666 (1/2")
Drill-Chuck			
Range 1 - 13 mm / B 16	Part no.	804652	–
Quick change chuck			
Range 1 - 13 mm / B 16	Part no.	804663	–
Maintenance unit with lubricator*			
Connection thread	Part no.	820455 A G 1/2	821608 A G 3/4
Maintenance unit without lubricator*			
Connection thread	Part no.	822409 A G 1/2	826982 A G 3/4
Replacement part set consisting of:			
vanes, sealant rings, o-rings and silencers	Part no.	444787 A / for Part no. 444570 A-D, H for Part no. 445353 B-D, H	444919 A / for Part no. 440066 A-D, H 444919 B / for Part no. 440066 E-F
	Part no.	444787 B / for Part no. 444570 E-G for Part no. 445353 E-G	

*) Maintenance unit consists of pressure regulator valve, filter and optionally with or without lubricator

**) no. of cylinder screws required

Of course you can also purchase individual replacement parts from us. Our standard maintenance units are ATEX conform. Please contact us if this is a requirement.

Allowable shaft loading see page 24.

Further notes for soundproofing see page 25.

Motor size 6 and Motor size 7

Series 67-

reversible

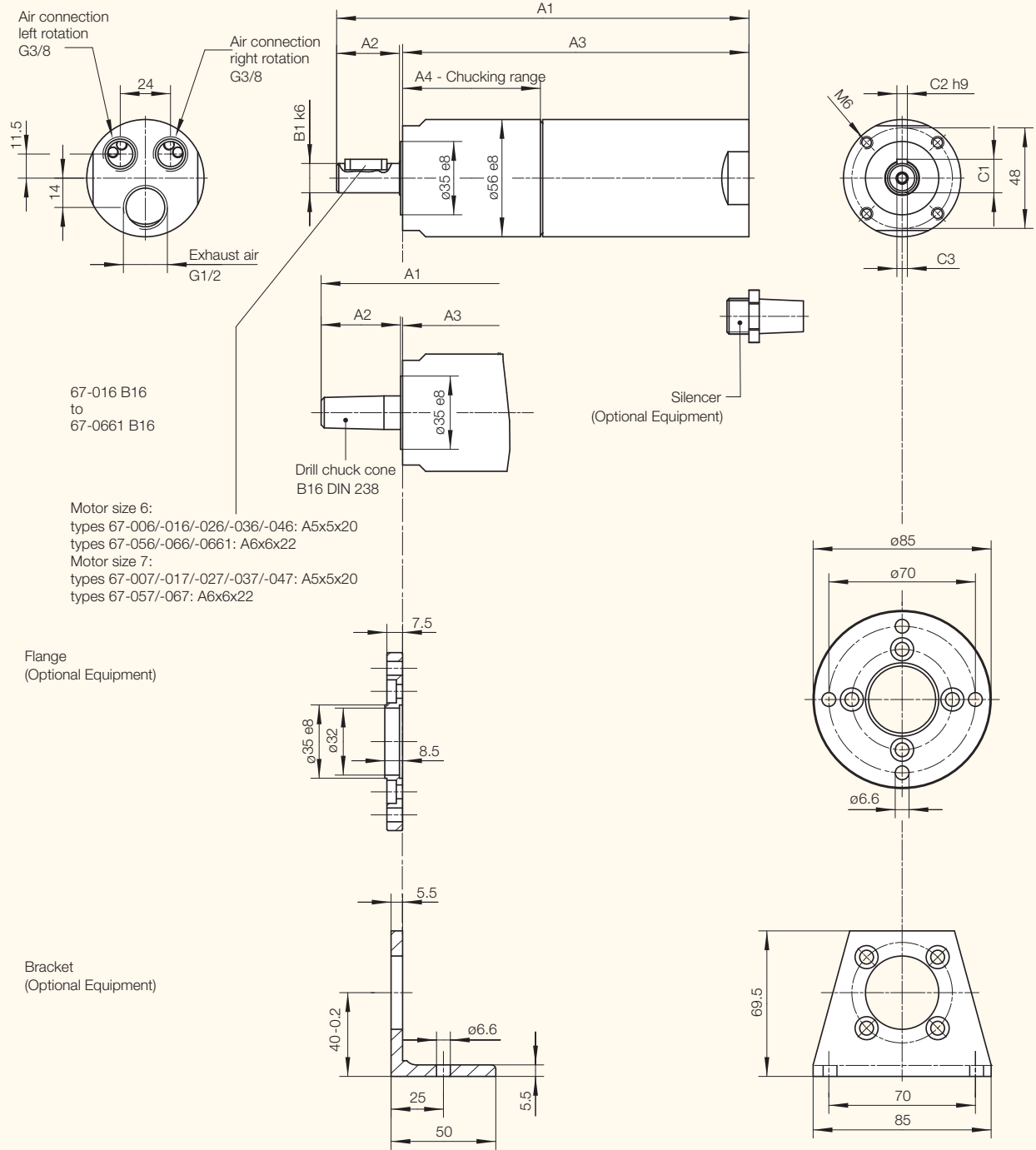

Dimensions in mm

p4402988

Motor size	Series 67-				Dimensions of motor (mm)							
	Type				A1	A2	A3	A4	B1	C1	C2	C3
6	67-006	67-016	67-026	67-036	197		166	66				
	67-046				215	30.5	184	84	14	16	5	M5x12
	67-056	67-066	67-0661		217	36	180	80.5	19	21.5	6	M6x12
	67-016B16	67-026B16	67-036B16		204		166	66				
	67-046B16				222	37.5	184	84				
	67-056B16	67-066B16	67-0661B16		219	38	180	80.5				
7	67-007	67-017	67-027	67-037	217		185.5	67				
	67-047				235	30.5	203.5	85	14	16	5	M5x12
	67-057	67-067			237	36	200	81	19	21.5	6	M6x12

570 W / 860 W ADVANCED LINE HIGH TORQUE AIR MOTOR

Motor size 6		reversible				
Series 67-	 II 2 GD c IIC T6 (80°C) Type	Part no.	67-146	67-156	67-166	67-516
Nominal-Power	W / HP		570 / 0.76	570 / 0.76	570 / 0.76	565 / 0.757
Nominal-Speed	rpm		75	55	37	20
Speed (idling)	rpm		150	110	74	40
Nominal-Torque	Nm / in.lbs		72 / 637.2	98 / 867.3	150 / 1327.5	265 / 2345.3
Start torque min.	Nm / in.lbs		108 / 955.8	147 / 1301	225 / 1991.3	400 / 3540
Air consumption	m ³ /min / cfm		0.85 / 30	0.85 / 30	0.85 / 30	0.85 / 30
Weight	kg / lbs		3.6 / 7.9	3.6 / 7.9	3.6 / 7.9	4.4 / 9.7
Hose I.D.	mm / in.		12 / 1/2	12 / 1/2	12 / 1/2	12 / 1/2

Performance data relate to an air pressure of 6 bar (85 PSI) and lubricated air. With oil-free operation the output will be reduced by 10 - 20%.

Motor size 7		reversible				
Series 67-	 II 2 GD c IIC T6 (80°C) Type	Part no.	67-147	67-157	67-167	67-517
Nominal-Power	W / HP		860 / 1.15	860 / 1.15	860 / 1.15	850 / 1.14
Nominal-Speed	rpm		75	55	35	20
Speed (idling)	rpm		150	110	70	40
Nominal-Torque	Nm / in.lbs		110 / 973.5	150 / 1327.5	225 / 1991.3	400 / 3540
Start torque min.	Nm / in.lbs		160 / 1416	220 / 1947	335 / 2964.8	600 / 5310
Air consumption	m ³ /min / cfm		1.4 / 49.4	1.4 / 49.4	1.4 / 49.4	1.4 / 49.4
Weight	kg / lbs		3.8 / 8.4	3.9 / 8.6	3.9 / 8.6	4.7 / 10.3
Hose I.D.	mm / in.		12 / 1/2	12 / 1/2	12 / 1/2	12 / 1/2

Performance data relate to an air pressure of 6 bar (85 PSI) and lubricated air. With oil-free operation the output will be reduced by 10 - 20%.

Optional Equipment		for Motor size 6 / 7	
		Type 67-146 to 67-166 Type 67-147 to 67-167	Type 67-516 Type 67-517
Flange	Part no.	413462	413463
necessary 4 cylinder-screws	Part no.	823148 (8 pieces)**	823545 (6 pieces)**
Bracket	Part no.	4446172	4446173
necessary 4 cylinder-screws	Part no.	823148 (8 pieces)**	823545 (6 pieces)**
Silencer: motor operates in one direction (right or left rotation)			
1 Hose nozzle	Part no.		410540 (3/8")
1 Silencer	Part no.		802671 (3/8")
1 Silencer	Part no.		802666 (1/2")
Silencer: Motor is reversible (right or left rotation)			
2 Hose nozzles	Part no.		410540 (3/8")
1 Silencer	Part no.		802666 (1/2")
		for Motor size 6	for Motor size 7
Maintenance unit with lubricator*	Part no.	820455 A	821608 A
Connection thread		G 1/2	G 3/4
Maintenance unit without lubricator*	Part no.	822409 A	826982 A
Connection thread		G 1/2	G 3/4
Replacement part set consisting of:			
vanes, sealant rings, o-rings and silencers	Part no.	444787 D / for Type 67-146 to 67-166 444787 E / for Type 67-516	444919 C / for Type 67-147 to 67-167 444919 D / for Type 67-517

*) Maintenance unit consists of pressure regulator valve, filter and optionally with or without lubricator

***) no. of cylinder screws required

<p>Of course you can also purchase individual replacement parts from us. Our standard maintenance units are ATEX conform. Please contact us if this is a requirement.</p>	<p>Allowable shaft loading see page 24.</p>	<p>Further notes for soundproofing see page 25.</p>
---	---	---

Motor size 6 and Motor size 7 High torque stainless steel motors

Series 67-

reversible

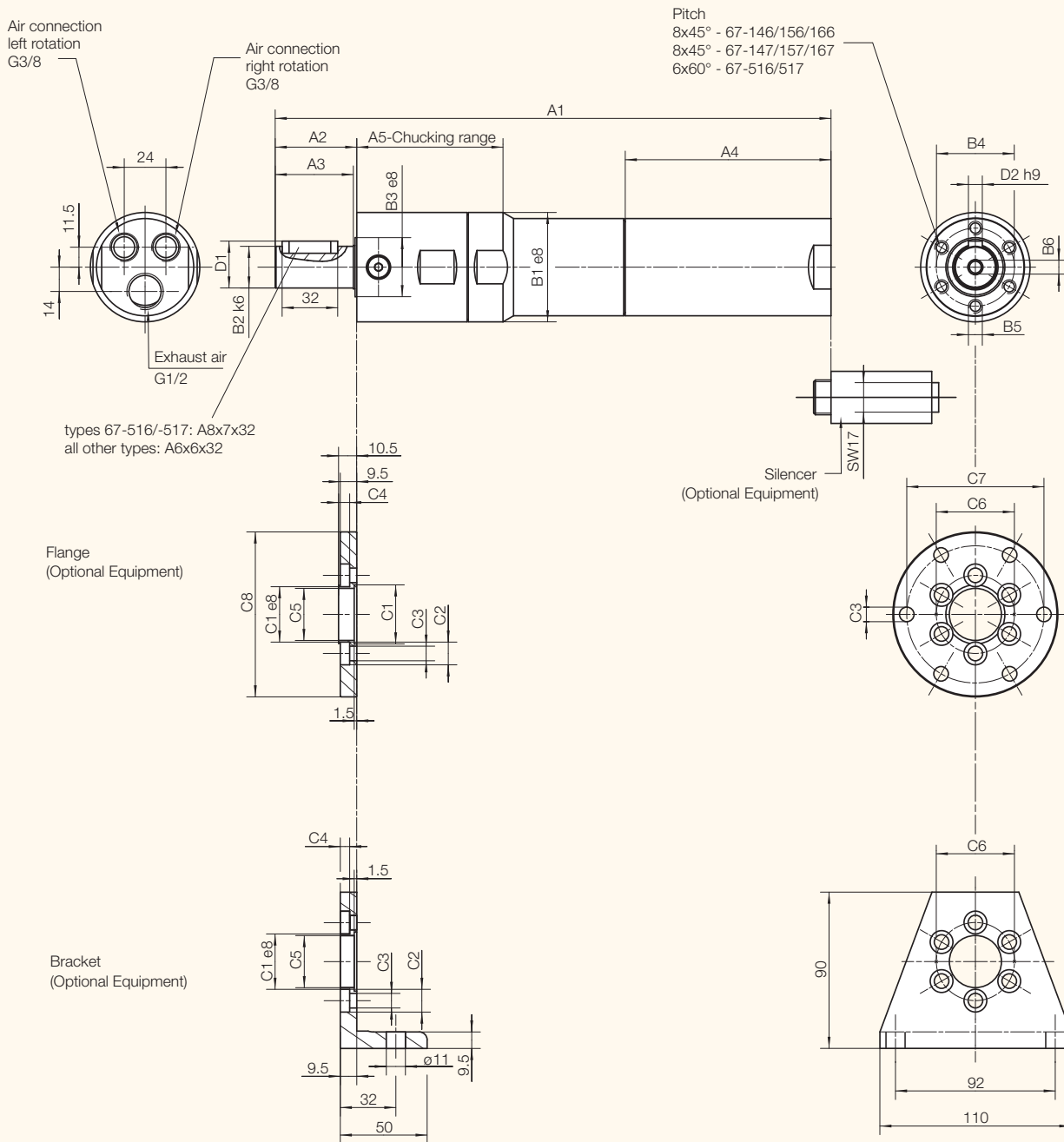

Dimensions in mm

p444338

Motor size	Series 67- Type			Dimensions of motor (mm)																				
				A1	A2	A3	A4	A5	B1	B2	B3	B4	B5	B6	C1	C2	C3	C4	C5	C6	C7	C8	D1	D2
6	67-146	67-156	67-166	283.4	44	42	98.5	61	56 e8	19	35	48	M6	M6x12	35	11	6.6	4.4	32	48	70	85	21.5	6
	67-516			347	47	45	98.5	84.2	63 h8	24	34	45	M8	M8x19	34	13.1	8.4	5.4	30	45	79	95	27	8

Motor size	Series 67- Type			Dimensions of motor (mm)																				
				A1	A2	A3	A4	A5	B1	B2	B3	B4	B5	B6	C1	C2	C3	C4	C5	C6	C7	C8	D1	D2
7	67-147	67-157	67-167	303.4	44	42	118.5	61	56 e8	19	35	48	M6	M6x12	35	11	6.6	4.4	32	48	70	85	21.5	6
	67-517			320.1	47	45	118.5	84.2	63 h8	24	34	45	M8	M8x19	34	13.1	8.4	5.4	30	45	79	95	27	8

1200 W ADVANCED LINE AIR MOTOR

Motor size 8		reversible					
Series 67-  II 2 GD c IIC T5 (95°C)	Type Part no.	67-008 444580 A	67-028 444580 B	67-038 444580 C	67-048 444580 D	67-058 444580 E	67-0581 444580 F
Nominal-Power	W / HP	1200 / 1.6	1200 / 1.6	1200 / 1.6	1200 / 1.6	1200 / 1.6	700 / 0.9
Nominal-Speed	rpm	4500	1250	550	350	160	100
Speed (idling)	rpm	9000	2500	1100	700	320	200
Nominal-Torque	Nm / in.lbs	2.5 / 22	9.2 / 81	21 / 186	33 / 292	71 / 628	66.9 / 592
Start torque min.	Nm / in.lbs	3.8 / 34	13.7 / 121	31 / 274	49 / 434	107 / 947	100 / 885
Air consumption	m ³ /min / cfm	1.6 / 56	1.6 / 56	1.6 / 56	1.6 / 56	1.6 / 56	1.1 / 39
Weight	kg / lbs	5.9 / 13	6.1 / 13.4	6.1 / 13.4	6.7 / 14.7	6.7 / 14.7	6.7 / 14.7
Hose I.D.	mm / in.	19 / 3/4	19 / 3/4	19 / 3/4	19 / 3/4	19 / 3/4	19 / 3/4

Performance data relate to an air pressure of 6 bar (85 PSI) and lubricated air. With oil-free operation the output will be reduced by 10 - 20%.

Optional Equipment

for Motor size 8		
Flange	Part no.	444627
necessary 4 cylinder-screws	Part no.	823545
Bracket	Part no.	444628
necessary 4 cylinder-screws	Part no.	823545
Silencer: motor operates in one direction (right or left rotation)		
1 Hose nozzle	Part no.	410509 (1/2")
1 Silencer	Part no.	802666 (1/2")
1 Silencer	Part no.	822086 (3/4")
Silencer: motor is reversible (right or left rotation)		
2 Hose nozzles	Part no.	410509 (1/2")
1 Silencer	Part no.	822086 (3/4")
Maintenance unit with lubricator*	Part no.	821608 A
Connection thread		G 3/4
Maintenance unit without lubricator*	Part no.	826982 A
Connection thread		G 3/4
Replacement part set consisting of: vanes, sealant rings, o-rings and silencers	Part no.	444788 A / for Part no. 444580 A-C 444788 B / for Part no. 444580 D-F

*) Maintenance unit consists of pressure regulator valve, filter and optionally with or without lubricator

<p>Of course you can also purchase individual replacement parts from us. Our standard maintenance units are ATEX conform. Please contact us if this is a requirement.</p>	<p>Allowable shaft loading see page 24.</p>	<p>Further notes for soundproofing see page 25.</p>
---	---	---

Motor size 8
Series 67-
 reversible

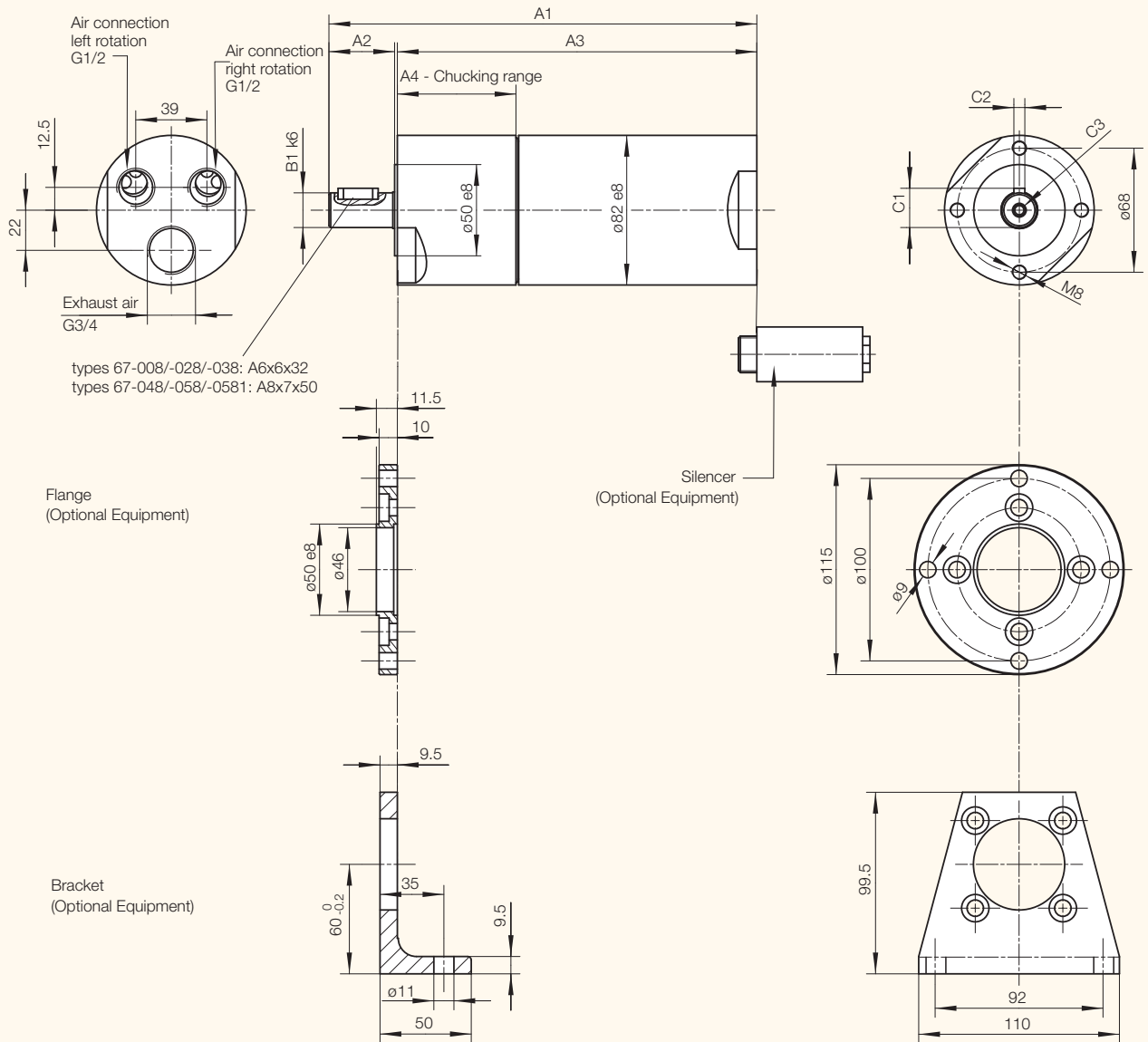

Dimensions in mm

p440236

Motor size	Series 67- Type			Dimensions of motor (mm)							
				A1	A2	A3	A4	B1	C1	C2	C3
8	67-008	67-028	67-038	235	35	197	65	19	21.5	6	M6x15
	67-048	67-058	67-0581	268	60	205	73	28	31	8	M10x20

1200 W ADVANCED LINE AIR MOTOR WITH INTEGRATED HOLDING BRAKE – ATEX conform

Motor size 8 with holding brake		reversible					
Series 67- ATEX conform	 II 2 GD c IIC Type T5 (95°C)	Type Part no.	67-008B 440097 A	67-028B 440097 B	67-038B 440097 C	67-048B 440097 D	67-058B 440097 E
Series 67- without ATEX-authorization		Type Part no.	67-008B 4400971A	67-028B 4400971B	67-038B 4400971C	67-048B 4400971D	67-058B 4400971E
Nominal-Power	W / HP		1200 / 1.6	1200 / 1.6	1200 / 1.6	1200 / 1.6	1200 / 1.6
Nominal-Speed	rpm		4500	1250	550	350	160
Speed (idling)	rpm		9000	2500	1100	700	320
Nominal-Torque	Nm / in.lbs		2.5 / 22	9.2 / 81	21 / 186	33 / 292	71 / 628
Start-Torque min.	Nm / in.lbs		3.8 / 34	13.7 / 121	31 / 274	49 / 434	107 / 947
Stall-Torque	Nm / in.lbs		5 / 44	18.4 / 162	42 / 372	66 / 584	142 / 1256
Break-Torque	Nm / in.lbs		6.2 / 55	23 / 204	52 / 460	83 / 735	177 / 1566
Air Consumption	m ³ /min / cfm		1.6 / 56	1.6 / 56	1.6 / 56	1.6 / 56	1.6 / 56
Weight	kg / lbs		9 / 19.8	9.2 / 20.2	9.2 / 20.2	9.7 / 21.3	9.7 / 21.3
Hose I.D.	mm / in.		19 / 3/4	19 / 3/4	19 / 3/4	19 / 3/4	19 / 3/4

Performance data relate to an air pressure of 6 bar (85 PSI) and lubricated air. With oil-free operation the output will be reduced by 10 - 20%.

Optional Equipment

for Motor size 8			
Flange	Part no.		444627
necessary 4 cylinder-screws	Part no.		823545
Bracket	Part no.		444628
necessary 4 cylinder-screws	Part no.		823545
Silencer: motor operates in one direction (right or left rotation)			
1 Hose nozzle	Part no.		410509 (1/2")
1 Silencer	Part no.		802666 (1/2")
1 Silencer	Part no.		822086 (3/4")
Silencer: motor is reversible (right or left rotation)			
2 Hose nozzles	Part no.		410509 (1/2")
1 Silencer	Part no.		822086 (3/4")
Maintenance unit with lubricator*	Part no.		821608 A
Connection thread			G 3/4
Maintenance unit without lubricator*	Part no.		826982 A
Connection thread			G 3/4
Replacement part set consisting of: vanes, sealant rings, o-rings and silencers	Part no.		444788 A / for Part no. 440097 (1) A-C 444788 B / for Part no. 440097 (1) D-F
Replacement part set for brake consisting of: discs, o-rings, pressure spring and silencer	Part no.		446096 B

*) Maintenance unit consists of pressure regulator valve, filter and optionally with or without lubricator



Pressure Regulator Valve

Of course you can also purchase individual replacement parts from us.

Our standard maintenance units are ATEX conform. Please contact us if this is a requirement.

Allowable shaft loading see page 24.

Further notes for sound-proofing see page 25.

A pressure regulator valve is included within our shipment of the ATEX conform brake motors. This safety valve turns off the air supply in the brake leads automatically when the pressure falls under 5 bar. This prevents an irregular temperature increase.

Motor size 8 with holding brake

Series 67-

reversible

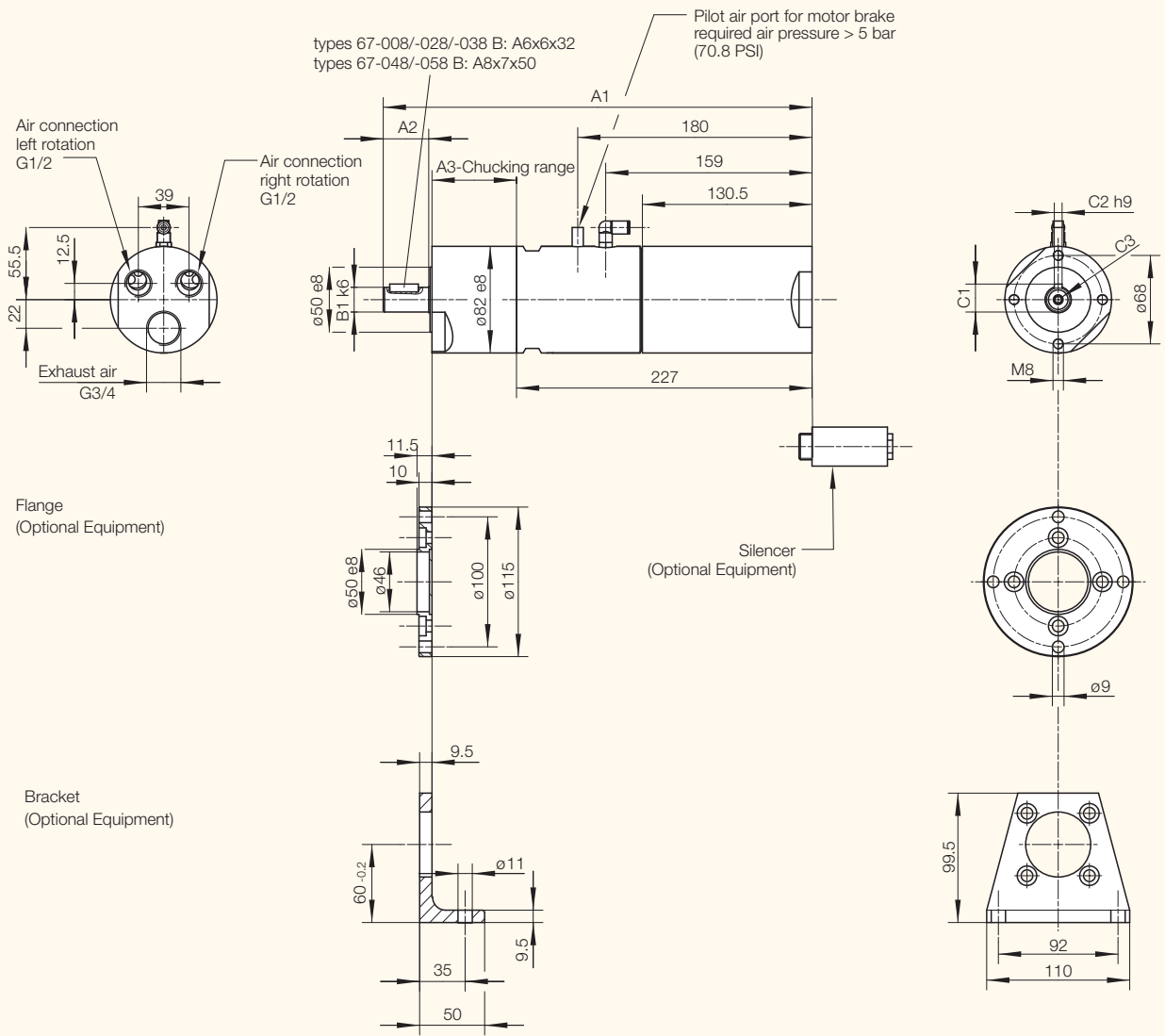

Motor size	Series 67- with holding brake Type		Dimensions of motor (mm)							
			A1	A2	A3	B1	C1	C2	C3	
8	67-008 B	67-028 B	67-038 B	330	35	65	19	21.5	6	M6x15
	67-048 B	67-058 B		363	60	73	28	31	8	M10x20

Maximum allowable shaft load of the drive shaft

flattened shaft
Motor size 0 and 1

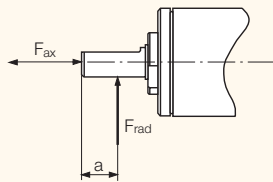

Motors with flattened shaft

Motor size	Part no.	Fax [N]	Frad [N]	a [mm]
MG 0	445115 B,C,D,E	140	180	6
MG 0	445462 E	140	180	6
MG 1	445127 A-D	200	220	7

Allowable force for 10 million spindle rotations with 90 % survival probability of bearing.

parallel key shaft
Motor size 2 to 8

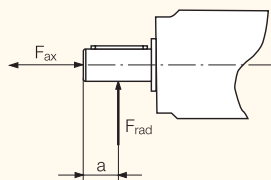

Motors with parallel key shaft

Motor size	Part no.	Part no. with holding brake	Fax [N]	Frad [N]	a [mm]
MG 2	444550 A-H		380	160	9
MG 2.5	444500 A-H	445760 A-F	570	720	12
MG 2.5	445184 A, B		1100	1200	22
MG 3	444560 A-D	445762 A-D	570	1130	14
MG 3	444560 E-H, K	445762 E, F	790	1070	15
MG 3	444560 I, L, M		1500	3500	21
MG 3	444560 N, O		1500	3500	20
MG 6	444570 A-D, H		1110	1300	15
MG 6	444570 E-G		1130	2090	18
MG 6	444570 I, K, L		1500	3500	21
MG 6	444570 M		1500	3500	22.5
MG 7	440066 A-D, H		1110	1300	15
MG 7	440066 E-F		1130	2090	18
MG 7	440066 I, K, L		1500	3500	21
MG 7	440066 M		1500	3500	22.5
MG 8	444580 A-C	440097 A-C, 4400971A-C	2330	2260	18
MG 8	444580 D-F	440097 D-E, 4400971D-E	2330	2700	30

Allowable force for 10 million spindle rotations with 90 % survival probability of bearing.

threaded shaft

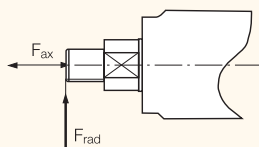

Motors with threaded spindle

Motor size	Part no.	Fax [N]	Frad [N]	a [mm]
MG 2	444950 A-H	380	110	0
MG 2.5	445910 A-L	570	450	0
MG 3	445682 A-D	570	860	0
MG 3	445682 E-H	790	820	0

Allowable force for 10 million spindle rotations with 90 % survival probability of bearing.

drill chuck

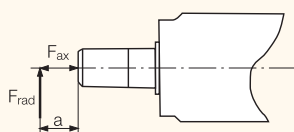

Motors with drill chuck

Motor size	Part no.	Fax [N]	Frad [N]	a [mm]
MG 6	445353 B-D, H	1100	150	80
MG 6	445353 E-G	1100	265	80

Allowable force for 10 million spindle rotations with 90 % survival probability of bearing.

TECHNICAL DATA

Noise level of the motors

Noise level for motors of the series 67 - without or with silencer (see optional equipment)

for Motor size	Noise level dB (A) without silencer	Noise level dB (A) mit silencer	Part no. silencer
0	98	85	811355
1	95	85	823236
2	99	92	823236
2.5	100	82	802675 / 802673
3	103	91	802673
6	104	94	802671 / 802666
7	106	88	802671 / 802666
8	108	95	802666 / 822086

Optional Silencer sets for further reduction of the noise level

Silencer sets for motors of the build series 67 - Attachment for only one rotation direction (clockwise or anticlockwise rotation)

for Motor size	Part no.	Hose length mm	Noise level dB (A)
1	446354 B	500	71
2	440015 B	500	70
2.5	440016 B	500	71
3	440018 B	500	70
6	440019 B	500	76
7	440019 B	500	79
8	440020 B	500	87

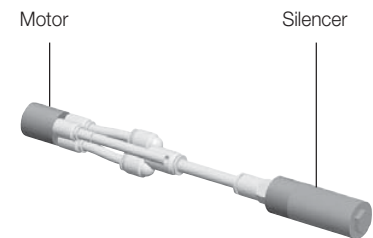

Silencer sets for motors of the build series 67 - Attachment adjustable (clockwise and anticlockwise rotation)

for Motor size	Part no.	Hose length mm	Noise level dB (A)
1	446354 A	500	71
2	440015 A	500	70
2.5	440016 A	500	71
3	440018 A	500	70
6	440019 A	500	76
7	440019 A	500	79
8	440020 A	500	87

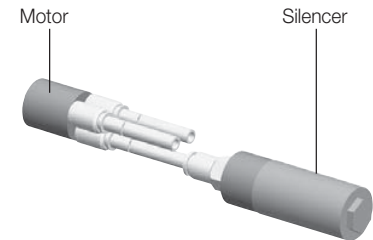

Use in potentially explosive environments



The correspondingly marked motors are suitable for use in potentially explosive environments.

Speed standard values (rpm) for HSS spiral-drills

Cutting Speed	35 m/min (115 ft./min)	28 m/min (90 ft./min)	25 m/min (80 ft./min)	14 m/min (45 ft./min)	11 m/min (35 ft./min)	7 m/min (23 ft./min)	22 m/min (70 ft./min)	12 m/min (40 ft./min)	50 m/min (165 ft./min)	90 m/min (300 ft./min)	165 m/min (540 ft./min)	210 m/min (690 ft./min)
Drill dia. mm/in.	Carbon steel			Alloy steel		Stainless steel	Cast-Iron		Copper Bronze Brass	Lightweight-Metal common alloy mild brass ¹⁾ hard		Magnesium-Alloy ²⁾
	up to 500 N/mm ² (30 long tons/ sq. in.)	500 - 700 N/mm ² (30 - 45 long tons/ sq. in.)	above 700 N/mm ² (45 long tons/ sq. in.)	700 - 900 N/mm ² (45 - 55 long tons/ sq. in.)	900 - 1100 N/mm ² (55 - 70 long tons/ sq. in.)		up to 180 N/mm ² (10 long tons/ sq. in.)	above 180 N/mm ² (10 long tons/ sq. in.)				
1/0.04	11000	8800	7800	4400	3400	2200	7000	3800	16000	28000	52000	66000
2/5/64	5500	4400	3900	2200	1700	1100	3500	1900	8000	14000	26000	33000
3/1/8	3700	3000	2600	1500	1100	730	2300	1300	5300	9000	17300	22000
4/5/32	2800	2200	2000	1100	850	550	1700	950	4000	7000	13000	16500
5/13/64	2200	1800	1600	880	680	440	1400	760	3200	5600	10400	13200
6/15/64	1900	1500	1300	735	570	365	1200	630	2700	4800	8700	11000
7/9/32	1600	1300	1100	630	485	315	1000	540	2300	4000	7400	9400
8/5/16	1400	1100	975	550	425	275	875	475	2000	3500	6500	8300
9/23/64	1200	975	865	490	380	245	780	420	1800	3100	5800	7400
10/25/64	1100	880	780	440	340	220	700	380	1600	2800	5200	6600

¹⁾ Speed therefore for triplet of duro-plates, hard-paper and hard tissues, however instead of the HSS-drills we recommend quickly steel-drills equipped with hard-metal K 10

²⁾ for thermos-plates, we recommend double the values

The layout of your air motor:

Calculating the motor power

$$P = \frac{M \times n}{9550}$$

P = Power Output in kW
M = Nominal-Torque in Nm
n = Nominal-Speed in rpm

The optimal working range of an air motor is close to the nominal speed. If you need lower speeds than are mentioned in the catalogue you can reduce the speed by throttling the exhaust air with only a slight loss of power. By throttling the supply air or decreasing the operating pressure the speed, torque and power are reduced.

All performance data of the DEPRAG air motors is based on operating pressure of 6 bar and the opening cross-section mentioned in the motor data. If your application conditions are different from this then you will find a comprehensive guide to the layout of our motors in brochure D 6000 E.

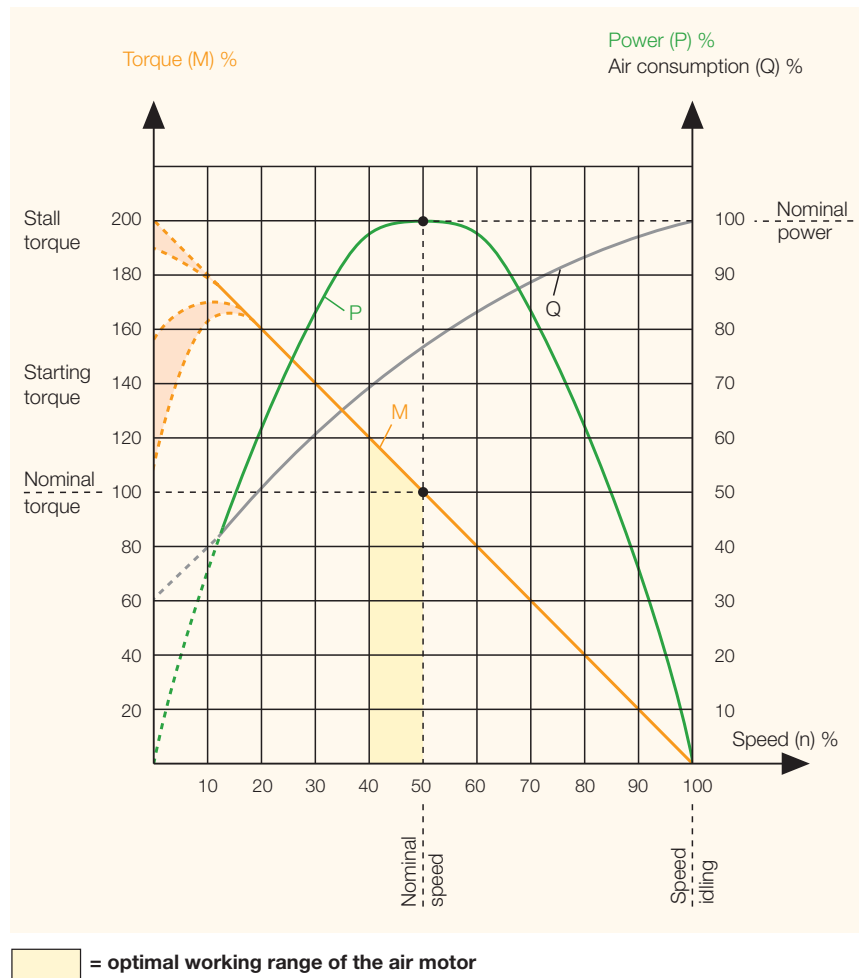

Do you need support in selecting the right drive system?

Tell us your operational conditions and our application consultants will be happy to help:

Application:	<input type="text"/>		
In what kind of environment will the motor be installed?	ATEX requirement / explosion safety?	<input type="checkbox"/> yes	<input type="checkbox"/> no
	if yes, which safety class:	<input type="text"/>	
	food industry conformity?	<input type="checkbox"/> yes	<input type="checkbox"/> no
	sterilisable?	<input type="checkbox"/> yes	<input type="checkbox"/> no
	acid resistant?	<input type="checkbox"/> yes	<input type="checkbox"/> no
	steam resistant?	<input type="checkbox"/> yes	<input type="checkbox"/> no
Application conditions:	constant operation (24 hrs, non-stop)	<input type="checkbox"/> yes	<input type="checkbox"/> no
	duty cycle in hrs/day:	<input type="text"/>	
	days/year:	<input type="text"/>	
	cycle time (s):	<input type="text"/>	
	motor loaded to stall?	<input type="checkbox"/> yes	<input type="checkbox"/> no
	self-locking?	<input type="checkbox"/> yes	<input type="checkbox"/> no
Required turn direction:	<input type="checkbox"/> left	<input type="checkbox"/> right	<input type="checkbox"/> reversible
	(view from air inlet)		
Motor performance:	power:	<input type="text"/>	W
	nominal torque:	<input type="text"/>	Nm
	nominal speed:	<input type="text"/>	rpm
Performance influencing application conditions:	operating pressure (at motor inlet):	<input type="text"/>	bar
	operation with lubricated air possible?	<input type="checkbox"/> yes	<input type="checkbox"/> no
	smallest opening cross-section of connection pieces and hoses?	<input type="text"/>	mm
External motor design:	<input type="checkbox"/> standard steel	<input type="checkbox"/> non-corrosive	<input type="checkbox"/> aluminium
	<input type="checkbox"/> plastics	<input type="checkbox"/> ceramics	
	other:	<input type="text"/>	
Drive spindle design:	drive shaft requirements:	<input type="text"/>	
	(e. g. keyed shafts, square end, hexagonal, collet, drill chuck taper, etc.)		
	required dimensions:	<input type="text"/>	
Motor fixture design:	mounting requirements: (bracket, flange, etc.)	<input type="text"/>	
	required dimensions:	<input type="text"/>	
Additional components:	<input type="checkbox"/> holding brake	<input type="checkbox"/> operational brake	
	gear box:	<input type="text"/>	
Price range:	<input type="text"/>		
Annual requirement:	<input type="text"/>		

DEPRAG

DEPRAG SCHULZ GMBH u. CO.

P.O. Box 1352, D-92203 Amberg, Germany
Carl-Schulz-Platz 1, D-92224 Amberg
Phone (+49) 9621 371-0, Fax (+49) 9621 371-120
www.deprag.com
info@deprag.de



CERTIFIED AS PER DIN EN ISO 9001
